



GRAND COUNTY COMMISSION REGULAR MEETING

Held virtually on Zoom
Moab, Utah

See below for instructions to give public comment via Zoom

Dial: **(669) 900 - 6833** Meeting ID: **851 7082 0571 #** Password (if needed): **214317** Unmute: ***6**

Link: <https://us02web.zoom.us/j/85170820571?pwd=M24yQjRIdEiCejUxTUlFeXFoZHNQQT09>

WATCH ON YOUTUBE - search for: "GRAND COUNTY UTAH GOVERNMENT"

AGENDA

Tuesday, March 1, 2022

2:00 p.m. Workshop proposed grant programs through the Economic Development Department

4:00 p.m.

- Call to Order**
- Citizens to Be Heard** (and again at approximately 6:00 pm)
We are receiving public comments by phone and online through Zoom.
Dial: **(669) 900 - 6833** Meeting ID: **851 7082 0571 #** Password (if needed): **214317**
Link: <https://us02web.zoom.us/j/85170820571?pwd=M24yQjRIdEiCejUxTUlFeXFoZHNQQT09>
Please note that when joining the meeting, you will be placed in a waiting room and will be added to the meeting by the moderator. Your comments will be recorded and on YouTube.
(Unmute for public comment: *6)
- Presentations**
 - A. Presentation and update from South Eastern Utah Health Department (SEUHD) on COVID-19 in Grand County (Brady Bradford, SEUHD Health Director) **(4:00 p.m.)**
 - B. Presentation on airport solar power project (Bill Hawley) **(4:15 p.m.)**
- Department Reports**
 - C. Report on Land Use Code updates on prioritization process (Elissa Martin, Planning & Zoning) **(4:30 p.m.)**
- Approval of Minutes** (Quinn Hall, Clerk/Auditor)
 - D. February 15, 2022 (Regular County Commission Meeting)
- Ratification of Payment of Bills**
- Commission Member Disclosures**
- General Commission Reports and Future Considerations**
- Elected Official Reports**
- Commission Administrator Report**
- General Business- Action Items- Discussion and Consideration of:**
 - E. Approving a letter of support for a preliminary agreement between the Thompson Springs Special Service District and Uranium Mill Tailings Remedial Action (UMTRA) for a feasibility study regarding the Green River Pipeline concept (John Ripley Corkery, Chair of TSSD and Commissioner Hadler)
 - F. Approving volunteer appointment to the Canyonlands Health Care Special Service District Board (Chair Woytek)
 - G. State Legislative Updates (Christina Sloan, County Attorney)
 - H. Approving bid award for mobile stage and associated purchase agreement (Mallory Nassau, Commission Administrator)

- I. Approving Clerk/Auditor mid-term vacancy appointment (Quinn Hall, Clerk/Auditor)
- ❑ **Consent Agenda- Action Items**
 - J. Approving a tribal consultation letter to the Ute Indian Tribe of the Uintah and Ouray Reservation regarding a HUD environmental review for Housing Authority of Southeastern Utah project funding
 - K. Approving a tribal consultation letter to the Navajo Nation, Arizona, New Mexico, and Utah regarding a HUD environmental review for Housing Authority of Southeastern Utah project funding
 - L. Approving a “No Historic Properties Affected” finding letter to the State Historical Preservation Office regarding a HUD environmental review for Housing Authority of Southeastern Utah project funding
- ❑ **Discussion Items**
 - M. Calendar items and special events (Mallory Nassau, Commission Administrator)
- ❑ **Public Hearings- Possible Action Items**
- ❑ **Closed Session(s)** (if necessary)
- ❑ **Adjourn**

NOTICE OF SPECIAL ACCOMMODATION DURING PUBLIC MEETINGS. In compliance with the Americans with Disabilities Act, individuals with special needs requests wishing to attend County Commission meetings are encouraged to contact the County two (2) business days in advance of these events. Specific accommodations necessary to allow participation of disabled persons will be provided to the maximum extent possible. T.D.D. (Telecommunication Device for the Deaf) calls can be answered at: (435) 259-1346. Individuals with speech and/or hearing impairments may also call the Relay Utah by dialing 711. Spanish Relay Utah: 1 (888) 346-3162

It is hereby the policy of Grand County that elected and appointed representatives, staff and members of Grand County Commission may participate in meetings through electronic means. Any form of telecommunication may be used, as long as it allows for real time interaction in the way of discussions, questions and answers, and voting.

At the Grand County Commission meetings/hearings any citizen, property owner, or public official may be heard on any agenda subject. The number of persons heard and the time allowed for each individual may be limited at the sole discretion of the Chair. On matters set for public hearings there is a three-minute time limit per person to allow maximum public participation. Upon being recognized by the Chair, please advance to the microphone, state your full name and address, whom you represent, and the subject matter. No person shall interrupt legislative proceedings.

Requests for inclusion on an agenda and supporting documentation must be received by 5:00 PM on the Wednesday prior to a regular Commission Meeting and forty-eight (48) hours prior to any Special Commission Meeting. Information relative to these meetings/hearings may be obtained at the Grand County Commission’s Office, 125 East Center Street, Moab, Utah; (435) 259-1346.

Indicators for Monitoring COVID-19 Community Levels and COVID-19 and Implementing COVID-19 Prevention Strategies

Accessible Version: <https://www.cdc.gov/coronavirus/2019-ncov/science/community-levels.html>

Overview and Scientific Rationale

February 25, 2022

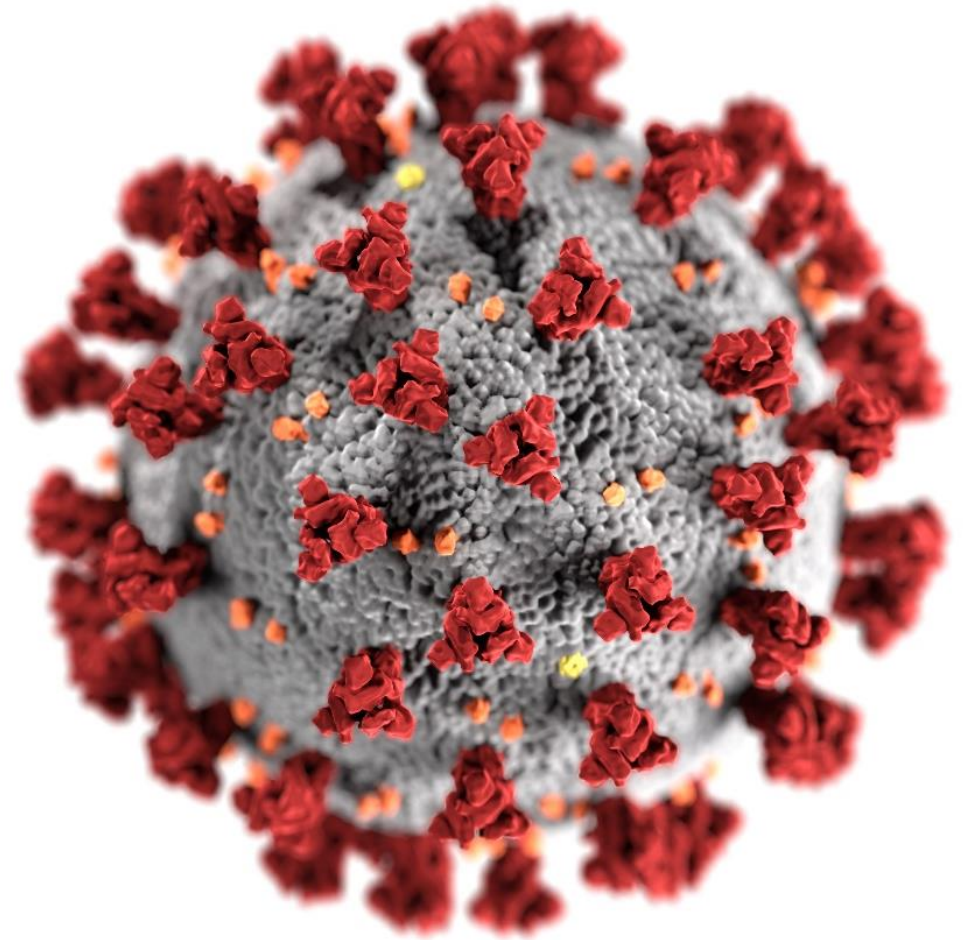

[cdc.gov/coronavirus](https://www.cdc.gov/coronavirus)

Why refocus efforts for monitoring COVID-19 in communities?

- **Shift from eliminating SARS-CoV-2 transmission towards more relevant metrics given current levels of population immunity and tools available**
 - **Current high levels of population immunity reduce risk of severe outcomes**
 - High rates of vaccination in population as a whole
 - Availability of boosters, and booster coverage among populations at high risk
 - In unvaccinated, high rates of infection-induced protection
 - **Breadth of tools available for public health and clinical care**
 - Broad access to vaccines, therapeutics, testing
- **Community measures should focus on minimizing the impact of severe COVID-19 illness on health and society**
 - Preventing medically significant illness
 - Minimizing burden on the healthcare system
 - Protecting the most vulnerable through vaccines, therapeutics, and COVID-19 prevention

CDC's Indicators of Community Transmission

Indicator	Low Transmission	Moderate Transmission	Substantial Transmission	High Transmission
Total new cases per 100,000 persons in the past 7 days	0-9	10-49	50-99	≥100
Percentage of Nucleic Acid Amplification Test results that are positive during the past 7 days	<5.0%	5.0%-7.9%	8.0%-9.9%	≥10.0%

- First released in September 2020
- Relied on two metrics to define community transmission: Total new cases per 100,000 persons in the past 7 days, and percentage of Nucleic Acid Amplification Test results that are positive during the past 7 days
- Used by CDC to inform setting-specific guidance and layered prevention strategies (e.g., screening testing in schools, masking, etc.)
- Public health practitioners, schools, businesses, and community organizations also rely on these metrics to inform decisions about prevention measures

The current state of the pandemic requires a refined approach to monitoring COVID-19

- Community transmission indicators were developed in fall 2020 (prior to availability of vaccines) and reflect goal of limiting transmission in anticipation of vaccines being available
- **Neither of the community transmission indicators reflects medically significant disease or healthcare strain**
- Community transmission levels are largely driven by case incidence, which does not differentiate mild and severe disease

Criteria for Selecting Community Indicators

- Indicators had to meet several criteria:
 1. Data available at the county level or allocated to county level from health service areas
 2. Data source provides nation-wide coverage
 3. Data reflect intended goals of emphasizing medically significant disease and healthcare strain
 4. Data reported at least weekly (or more often) with sufficient timeliness to allow data to inform decisions about prevention measures

Selecting COVID-19 Community Indicators

- Criteria were established to assess potential candidate indicators
- Review of historical data from 18 months of the pandemic
 - Compiled available indicators across data systems
 - Assessed trends in increases and declines in cases, hospital capacity, other indicators
 - Reviewed historical data and thresholds used in [COVID-19 Community Profile Report | HealthData.gov](#) and [State Profile Report](#)
- Assessed candidate indicators against criteria and eliminated those that did not fully meet established criteria
 - Deaths, while an important metric, are a lagging indicator and have low numbers which result in unstable estimates at local levels
 - Emergency Department visits from the [National Syndromic Surveillance Program](#) are a promising indicator, but include 71% of emergency departments, so do not have national coverage

Final Selection of COVID-19 Community Indicators

- Narrowed the list of candidate indicators based on criteria:
 - *New hospital admissions with confirmed COVID-19/100,000 people and percent of inpatient beds occupied with COVID-19 patients* selected as best candidates
 - ICU beds occupied, new hospital admissions/100 beds, test positivity, and metrics reflecting percent change (e.g., in new admissions, new cases) eliminated
 - New cases retained as a potential candidate to assess performance as leading indicator

Establishing Thresholds for COVID-19 Community Levels

- Used correlation analyses and thresholds from Community Profile Reports and State Profile Reports to assess potential thresholds
- Correlations indicate:
 - 100 cases/100,000 population per week corresponds to about 3-4% of COVID-19 inpatient bed utilization, 6-10 new admissions/100,000 population
 - Inpatient bed occupancy is about half that of ICU occupancy
 - Fewer new admissions, fewer admissions per case, and lower inpatient bed utilization in areas with higher vaccination coverage
- Established candidate thresholds, then tested to calibrate levels

Indicator Performance Analysis Results

Question	Answer
What is the appropriate outcome variable?	Deaths, with ICU bed utilization as a secondary indicator. Both are correlated with transmission levels and COVID-19 community levels.
What is the optimal lag between the community level/transmission level and the outcome?	Correlation with death rates for new cases, hospital admissions and bed utilization peaks when the lag is set at 3 weeks.
How do individual indicators such as admissions, inpatient bed utilization predict outcomes?	Individual indicators have moderate correlation with deaths/100k three weeks later (~0.3) at the county level and high correlation (~0.8) at the state level. COVID-19 community levels (county: 0.3, state: 0.7) have higher correlations with death rates than transmission levels (county: 0.2, state: 0.5)
Which scheme (transmission levels or COVID-19 community levels) is more useful for identifying regions that will experience severe outcomes?	COVID-19 community levels are a more effective categorization scheme for identifying regions that will experience high death rates 3 weeks later according to multiple metrics (correlation, AUROC).
Should the thresholds be adjusted in response to this analysis?	Adjusting thresholds shifts the balance between levels and more balanced categorizations are more informative. COVID-19 community levels result in more balanced categories/levels.

Do community transmission levels or COVID-19 community levels better predict deaths and ICU utilization in counties?

- Do higher transmission levels and higher COVID-19 community levels correspond to more severe outcomes 3 weeks later?
 - Multiple analyses using different indicator thresholds were conducted to optimize the levels. COVID-19 community levels provided consistently better prediction compared with community transmission.
 - Analyses used AUROC (area under receiver operating characteristic). This can be interpreted as the probability that given two randomly selected observations from different levels, the one with the more severe outcome comes from a higher transmission/COVID-19 community level. Data analyzed included historical data from March 2021-January 2022
 - A score of 0.5 would correspond to random guessing and a score of 1 would indicate that worse outcomes always correspond to higher COVID-19 community levels/transmission levels.
- COVID-19 community levels are better predictors of deaths and ICU utilization 3 weeks later than community transmission levels at the county level.
 - Analyses using AUROC, Spearman's correlation, and Pearson's correlation coefficient provide consistent results.
 - Analyses used 4-level schemes for COVID-19 community levels and then were pared down to 3 levels based on end-user feedback.

Indicator Thresholds were Further Refined

- Compared different combinations of thresholds
 - With/without case threshold, and with different case thresholds (100, 200, 500, 1000 cases/100,000/week)
 - Different levels of *new COVID-19 hospital admissions* and *inpatient beds occupied by COVID-19 patients*
- Optimized levels based on thresholds with consistently higher performance at predicting ICU bed utilization, deaths, new admissions, and inpatient bed use 3 weeks later

CDC's COVID-19 Community Levels and Indicators

New Cases (per 100,000 population in the last 7 days)	Indicators	Low	Medium	High
Fewer than 200	New COVID-19 admissions per 100,000 population (7-day total)	<10.0	10.0-19.9	≥20.0
	Percent of staffed inpatient beds occupied by COVID-19 patients (7-day average)	<10.0%	10.0-14.9%	≥15.0%
200 or more	New COVID-19 admissions per 100,000 population (7-day total)	NA	<10.0	≥10.0
	Percent of staffed inpatient beds occupied by COVID-19 patients (7-day average)	NA	<10.0%	≥10.0%

The COVID-19 community level is determined by the higher of the inpatient beds and new admissions indicators, based on the current level of new cases per 100,000 population in the past 7 days

COVID-19 community levels are better predictors of deaths and ICU utilization in communities

- The proposed COVID-19 community levels provide a **sizeable improvement** over the community transmission levels in identifying regions that will experience severe outcomes 3 weeks later
 - To prevent deaths and ICU bed use, COVID-19 community levels using new indicator metrics provide more robust measures
 - COVID-19 community levels result in more meaningful differences between categories

COVID-19 community levels on March 30, 2021 (post Alpha)

Daily Trends in Number of COVID-19 Cases in The United States Reported to CDC

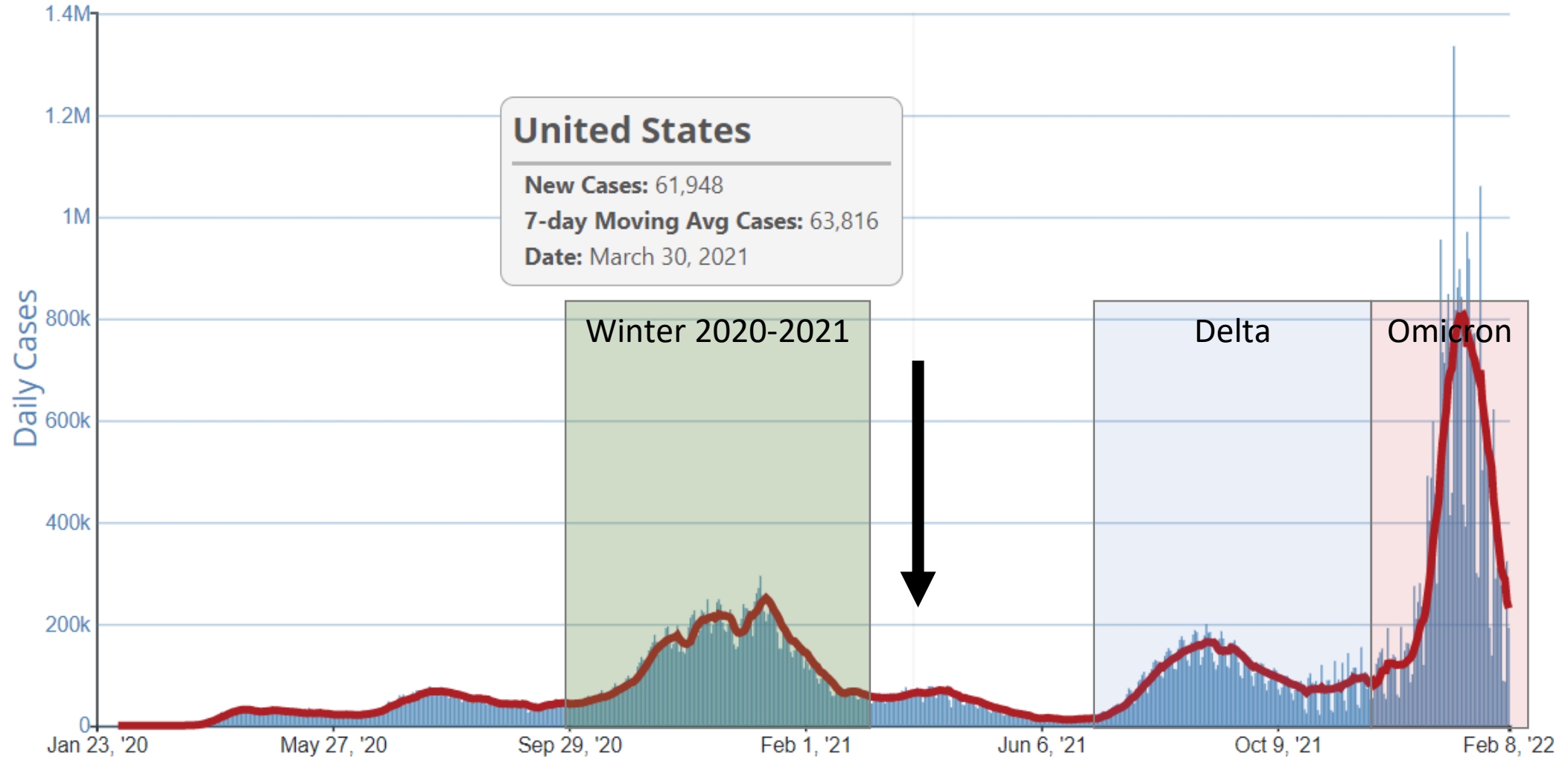

COVID-19 Community Levels on March 30, 2021

COVID-19 Community Level

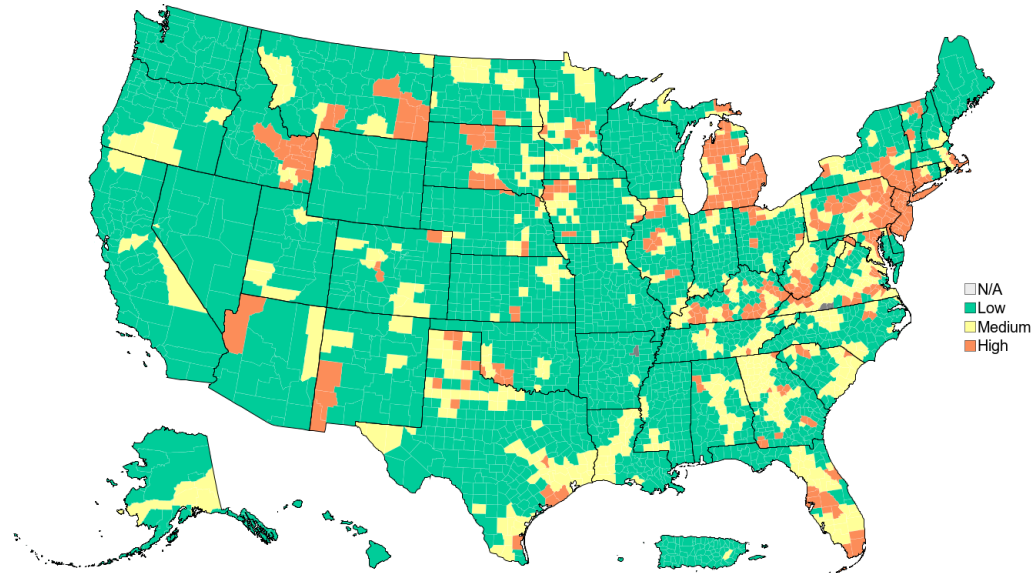

□ N/A
 ■ Low
 ■ Medium
 ■ High

% of Counties % of Pop.

Low	67.3%	56.9%
Medium	22.0%	23.4%
High	10.6%	19.7%

Community Transmission

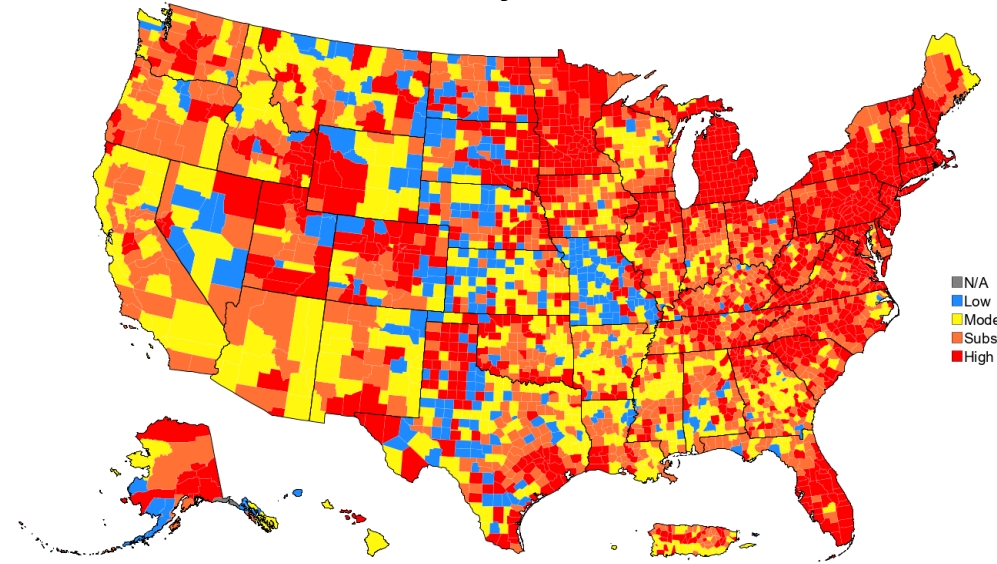

□ N/A
 ■ Low
 ■ Moderate
 ■ Substantial
 ■ High

% of Counties % of Pop.

Low	9.3%	1.4%
Moderate	22.0%	17.3%
Subst.	28.3%	26.4%
High	40.5%	54.9%

COVID-19 community levels on July 30, 2021 (rise of Delta)

Daily Trends in Number of COVID-19 Cases in The United States Reported to CDC

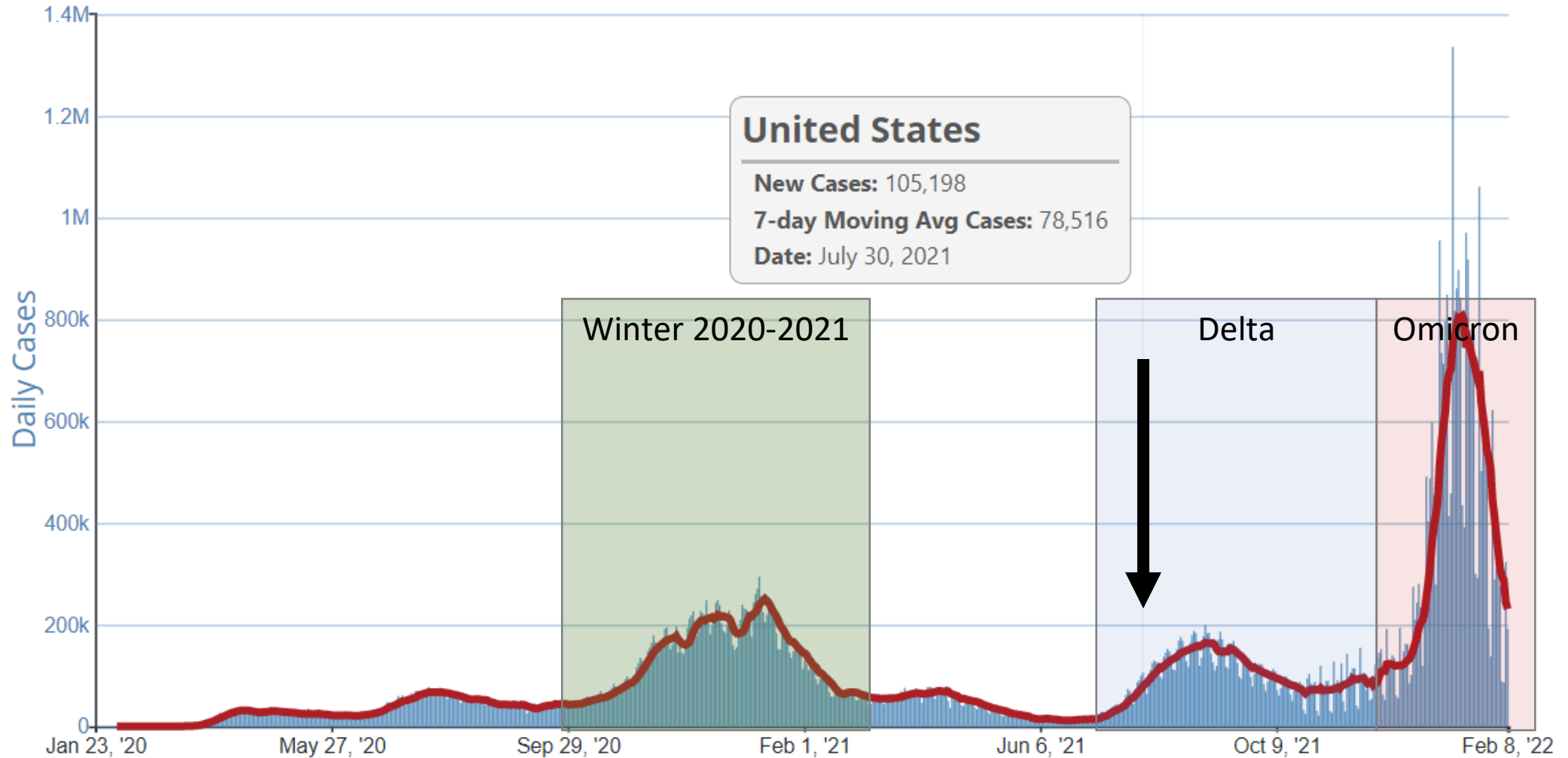

COVID-19 Community Levels on July 30, 2021

COVID-19 Community Level

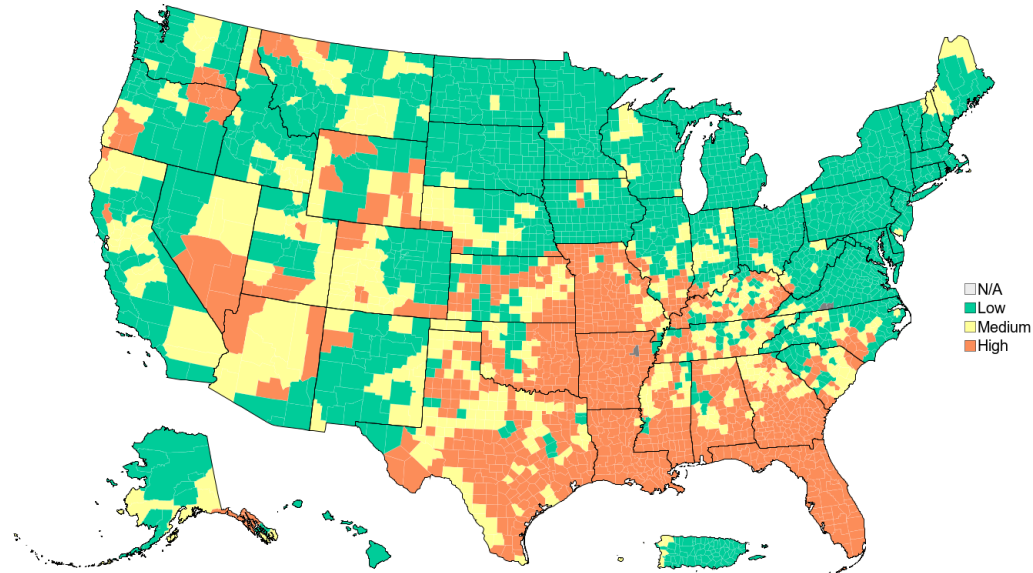

% of Counties % of Pop.

Low	49.6%	57.7%
Medium	20.2%	18.3%
High	30.1%	23.9%

Community Transmission

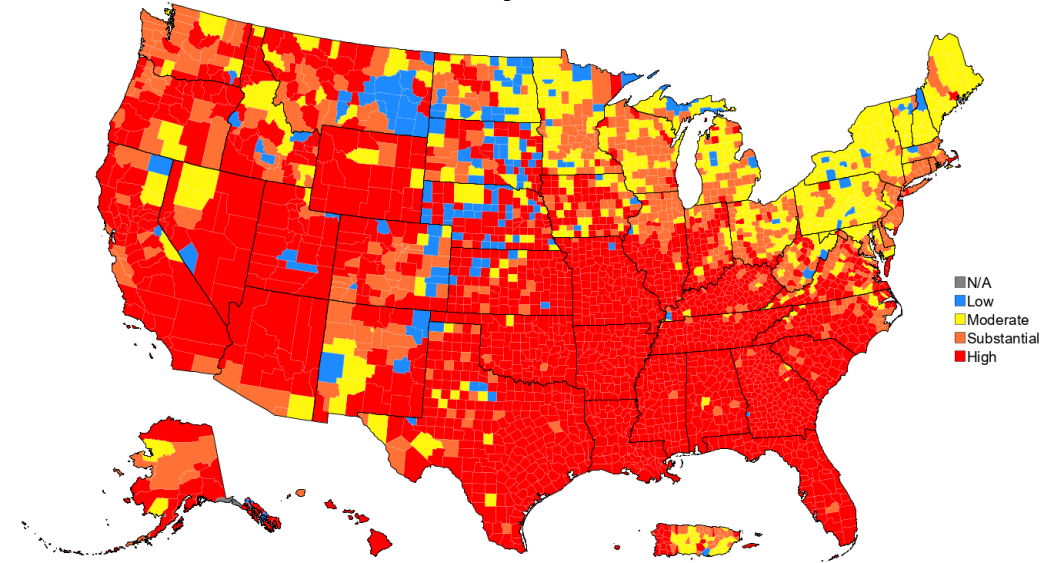

% of Counties % of Pop.

Low	4.8%	0.4%
Moderate	15.7%	12.1%
Subst.	18.2%	28.0%
High	61.3%	59.4%

COVID-19 community levels on September 3, 2021 (peak of Delta)

Daily Trends in Number of COVID-19 Cases in The United States Reported to CDC

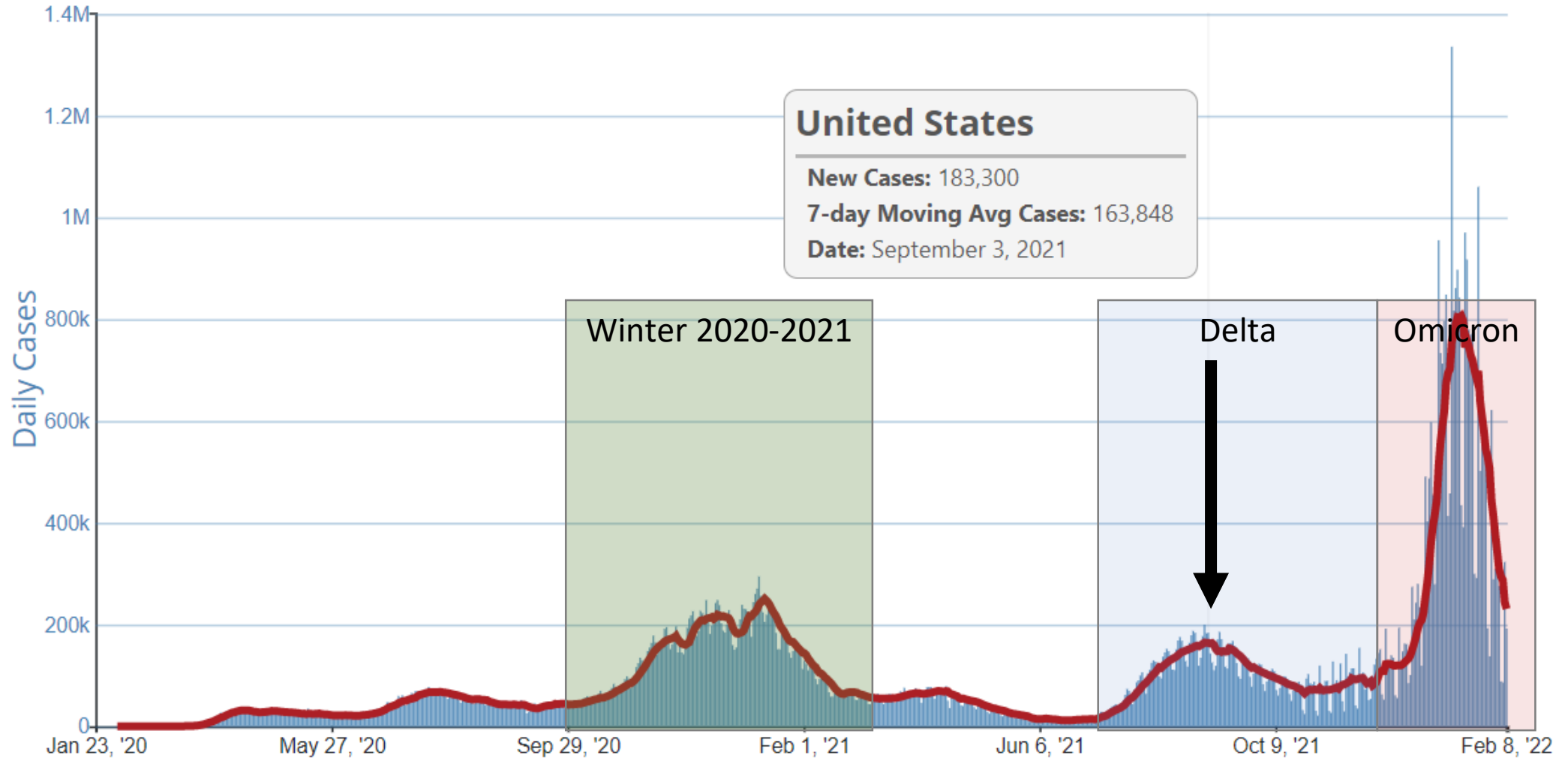

COVID-19 Community Levels on September 3, 2021

COVID-19 Community Level

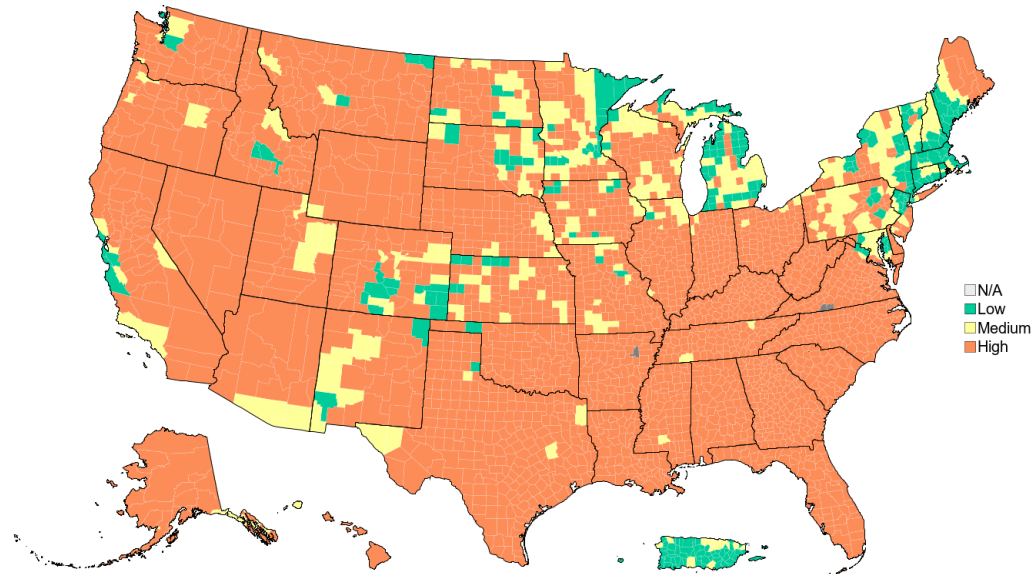

% of Counties % of Pop.

Low	8.1%	14.9%
Medium	12.2%	20.5%
High	79.6%	64.7%

Community Transmission

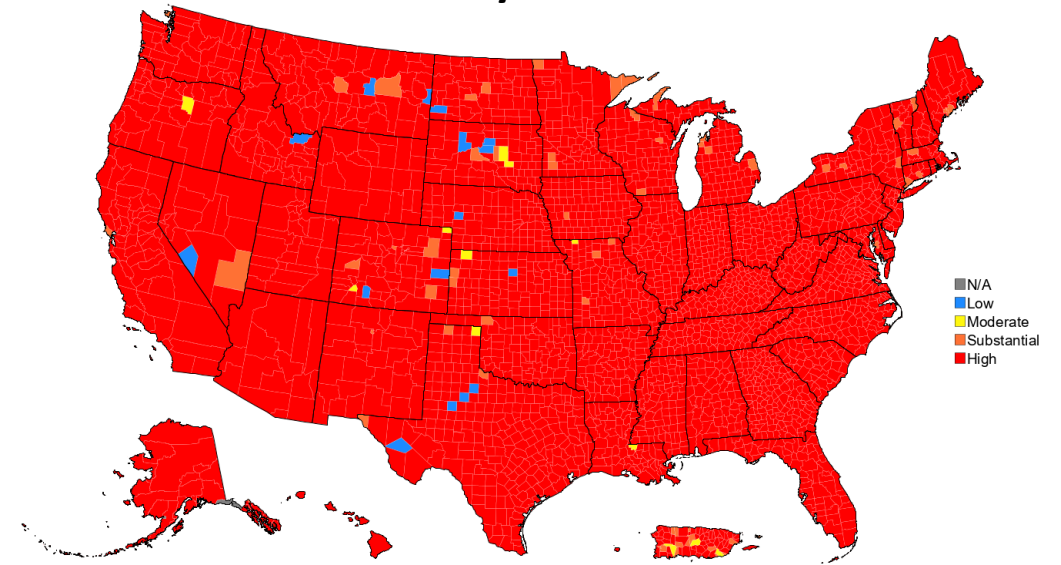

% of Counties % of Pop.

Low	0.5%	0.0%
Moderate	0.4%	0.0%
Subst.	2.0%	1.2%
High	97.0%	98.8%

COVID-19 community levels on November 5, 2021 (between Delta and Omicron)

Daily Trends in Number of COVID-19 Cases in The United States Reported to CDC

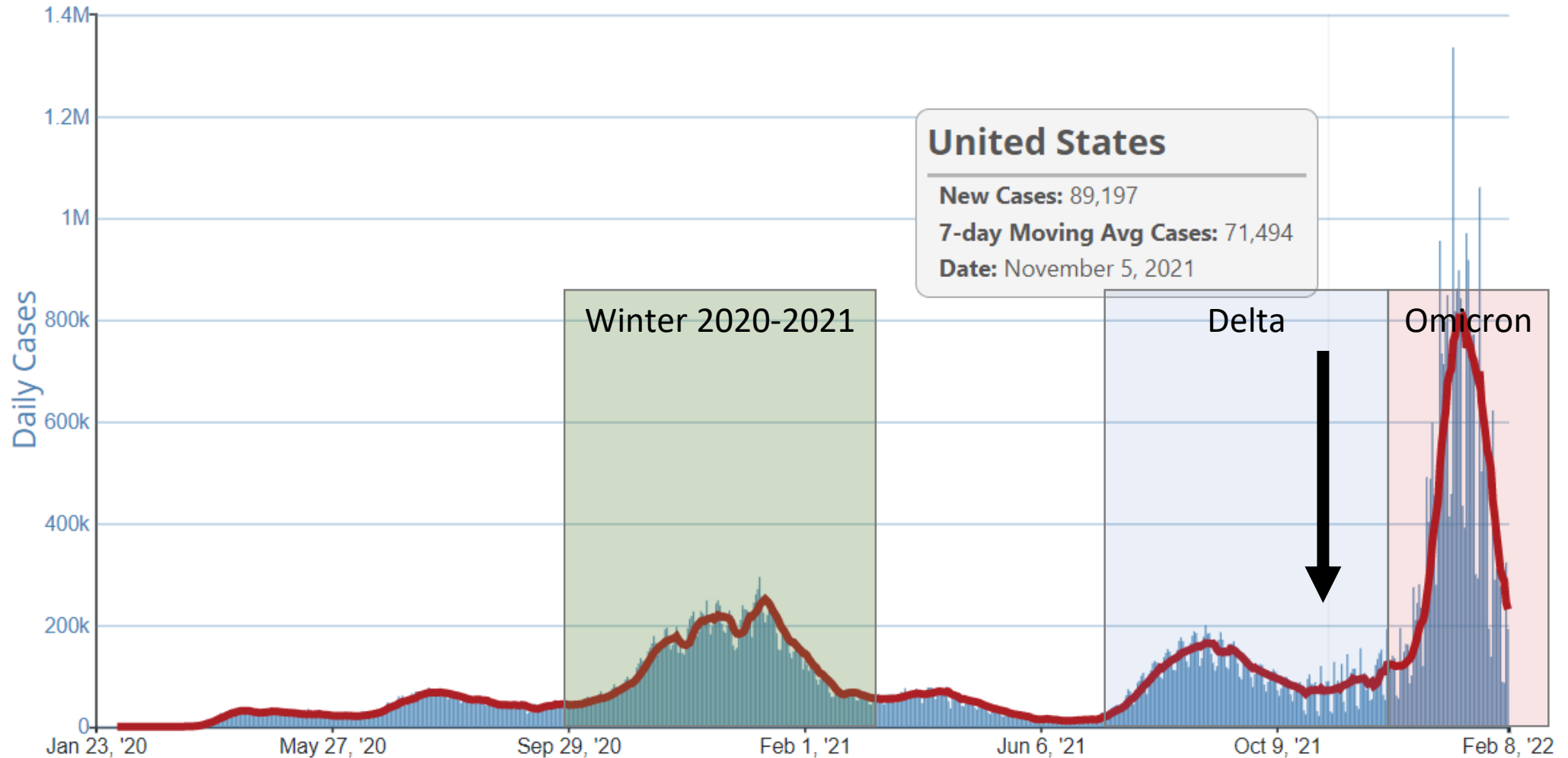

COVID-19 Community Levels on November 5, 2021

COVID-19 Community Level

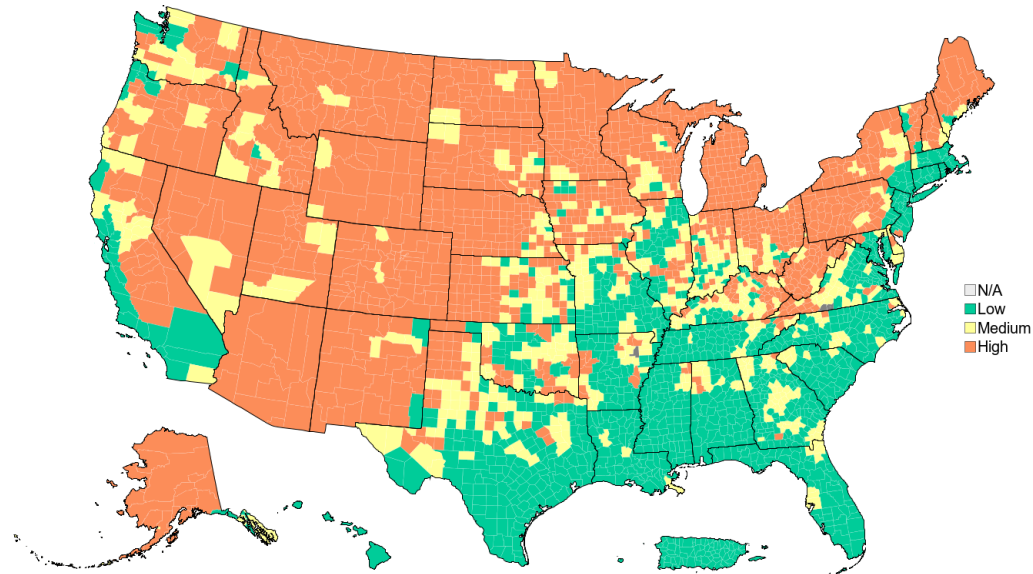

□ N/A
 ■ Low
 ■ Medium
 ■ High

% of Counties % of Pop.

Low	38.3%	58.5%
Medium	21.5%	16.5%
High	40.1%	25.0%

Community Transmission

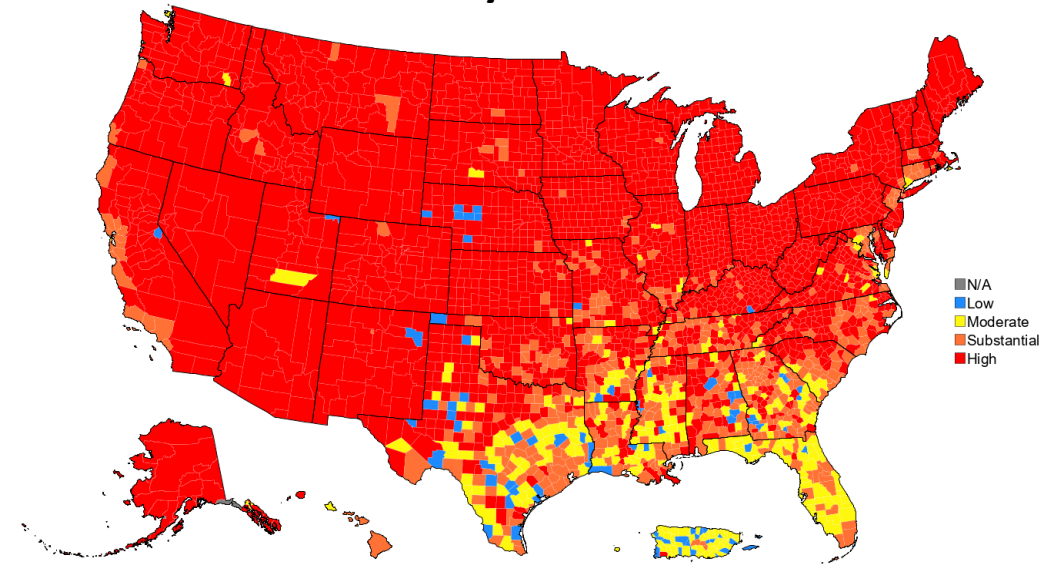

■ N/A
 ■ Low
 ■ Moderate
 ■ Substantial
 ■ High

% of Counties % of Pop.

Low	2.6%	0.6%
Moderate	9.4%	8.6%
Subst.	16.8%	32.5%
High	71.2%	58.2%

COVID-19 community levels on January 15, 2022 (peak of Omicron)

Daily Trends in Number of COVID-19 Cases in The United States Reported to CDC

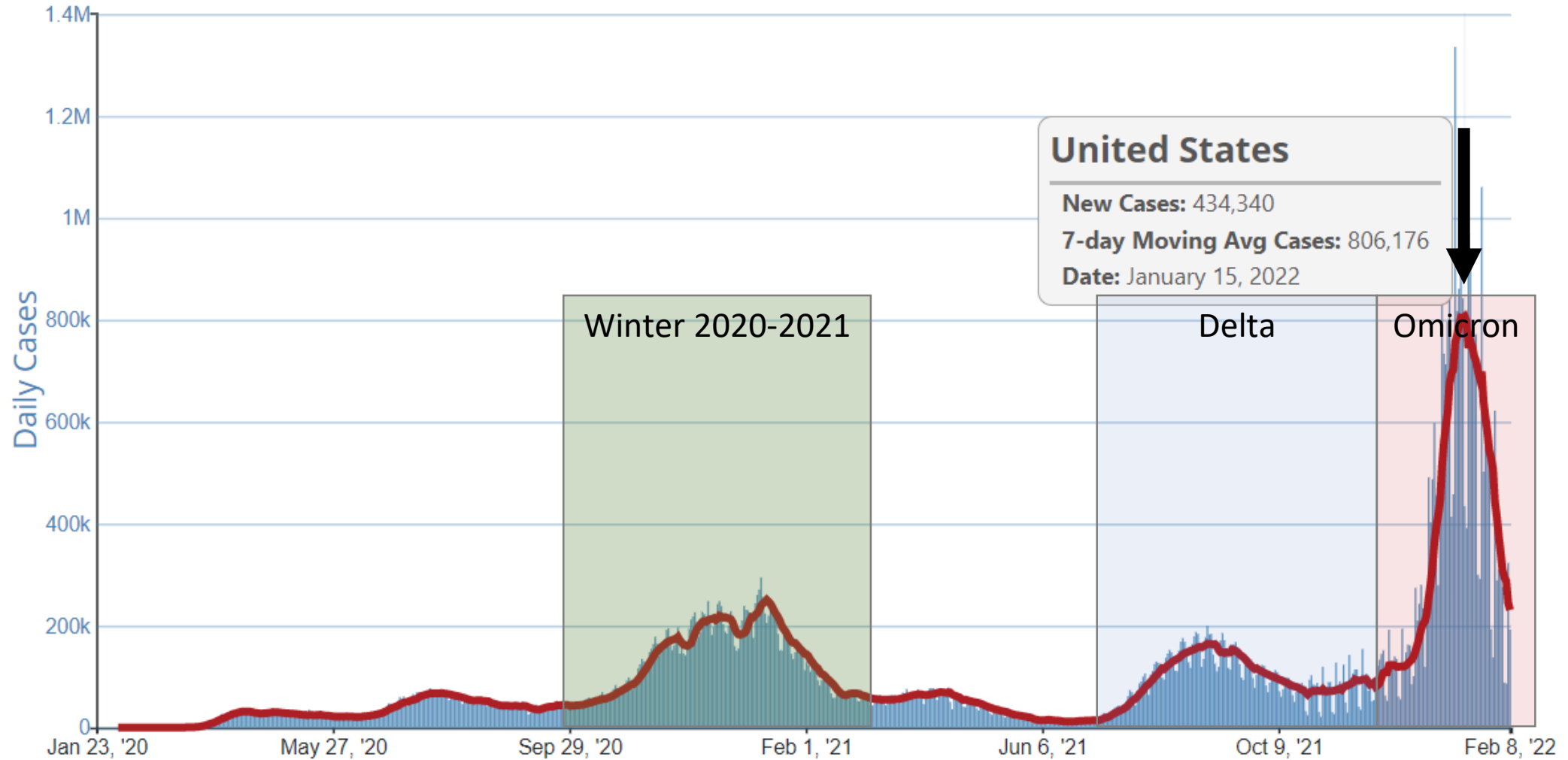

COVID-19 Community Levels on January 15, 2022

COVID-19 Community Level

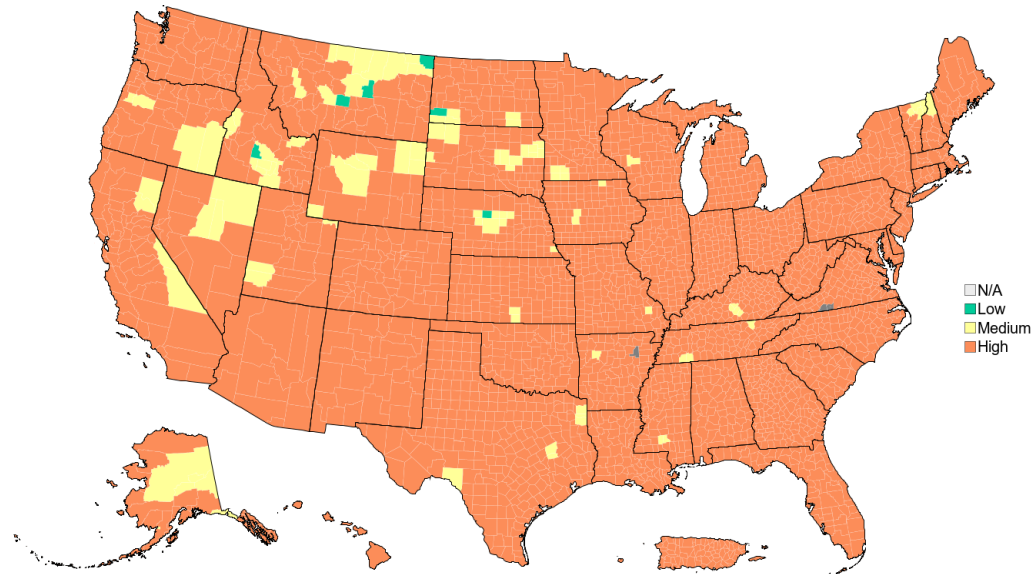

□ N/A
 ■ Low
 ■ Medium
 ■ High

% of Counties % of Pop.

Low	0.2%	0.0%
Medium	3.2%	0.5%
High	96.5%	99.5%

Community Transmission

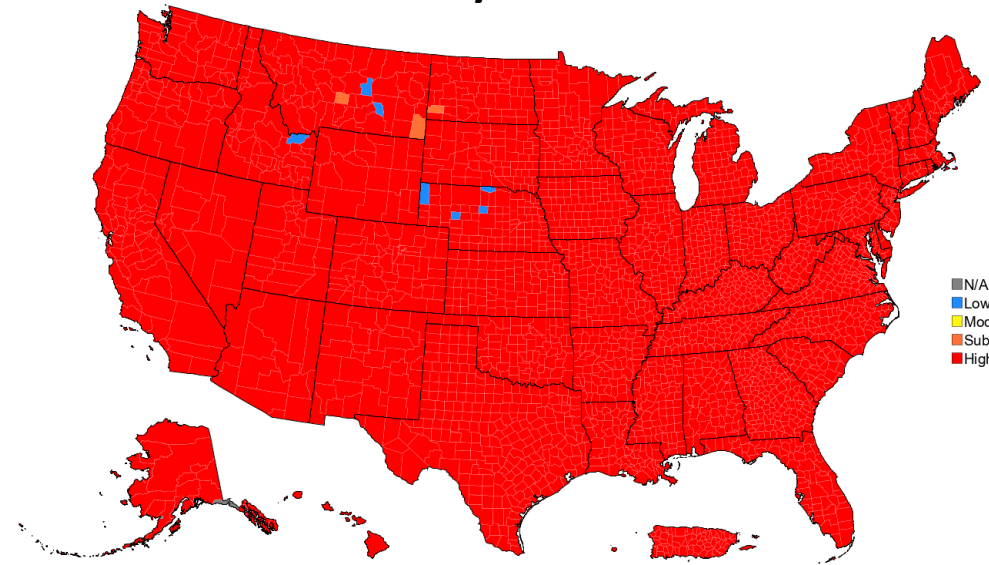

□ N/A
 ■ Low
 ■ Moderate
 ■ Substantial
 ■ High

% of Counties % of Pop.

Low	0.3%	0.0%
Moderate	0.0%	0.0%
Subst.	0.1%	0.0%
High	99.6%	100.0%

Proposed Framework for Monitoring and Prevention

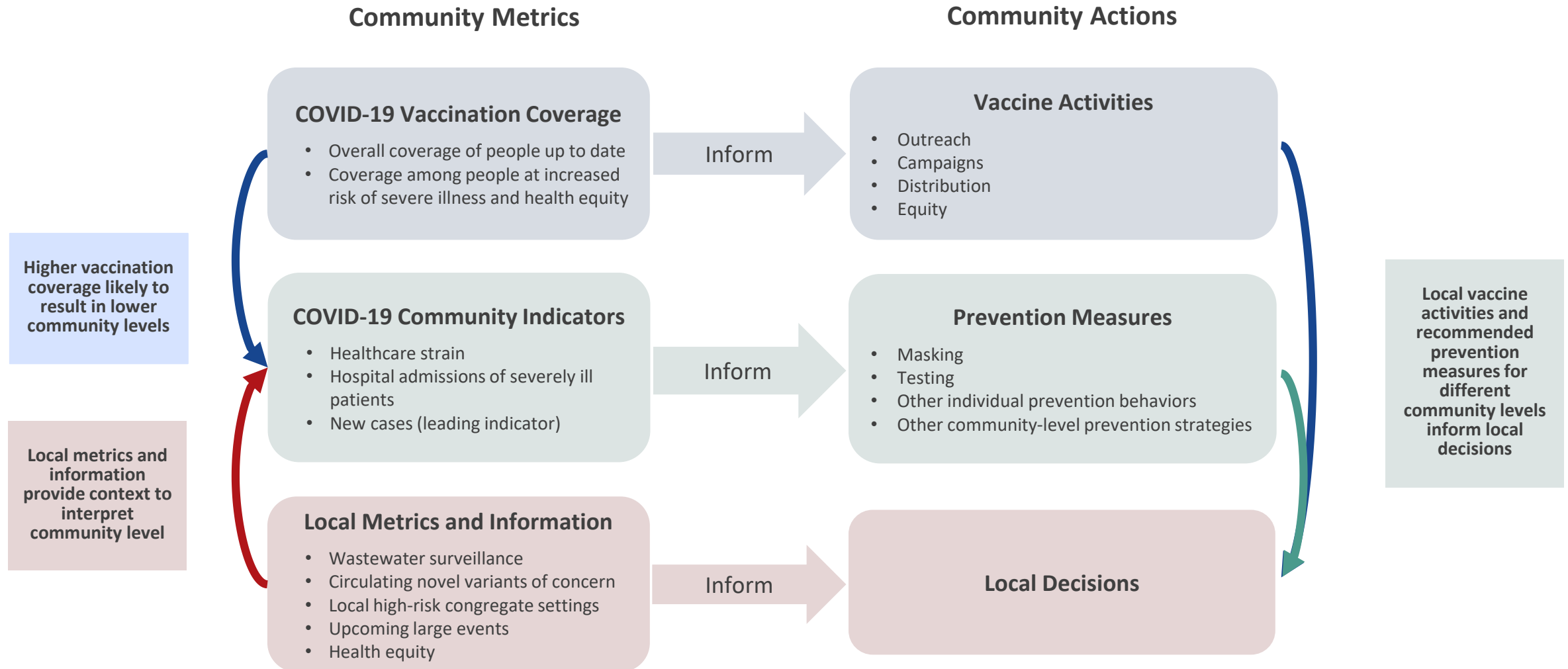

Implications for Using COVID-19 Community Levels to Inform Public Health Recommendations

- COVID-19 community levels can inform recommendations for **community-level preventive strategies** and **individual preventive behaviors**
- At higher COVID-19 community levels recommendation would include:
 - Masking
 - Testing Strategies (e.g., screening testing)
 - High-risk individuals and their household or social contacts (e.g., masking, testing, and access to treatments)
 - Setting-specific recommendations (e.g., K-12 schools, healthcare)
 - High-risk congregate settings (e.g., masking and screening testing)

Key Considerations

- Vaccination is the leading public health prevention strategy to prevent severe disease and deaths from COVID-19.
- People who are up to date on vaccines have much lower risk of severe illness and death from COVID-19 compared with unvaccinated people.
- When making decisions about individual preventive behaviors and community prevention strategies in addition to vaccination, people and health officials should consider the COVID-19 community level.
- Health departments should consider health equity, and make use of other surveillance information (wastewater, ED surveillance, etc.), if available, to inform local decisions.
- Layered prevention strategies — like staying up to date on vaccines and wearing masks — can help prevent severe disease and reduce strain on the healthcare system.

COVID-19 community levels on February 24, 2022

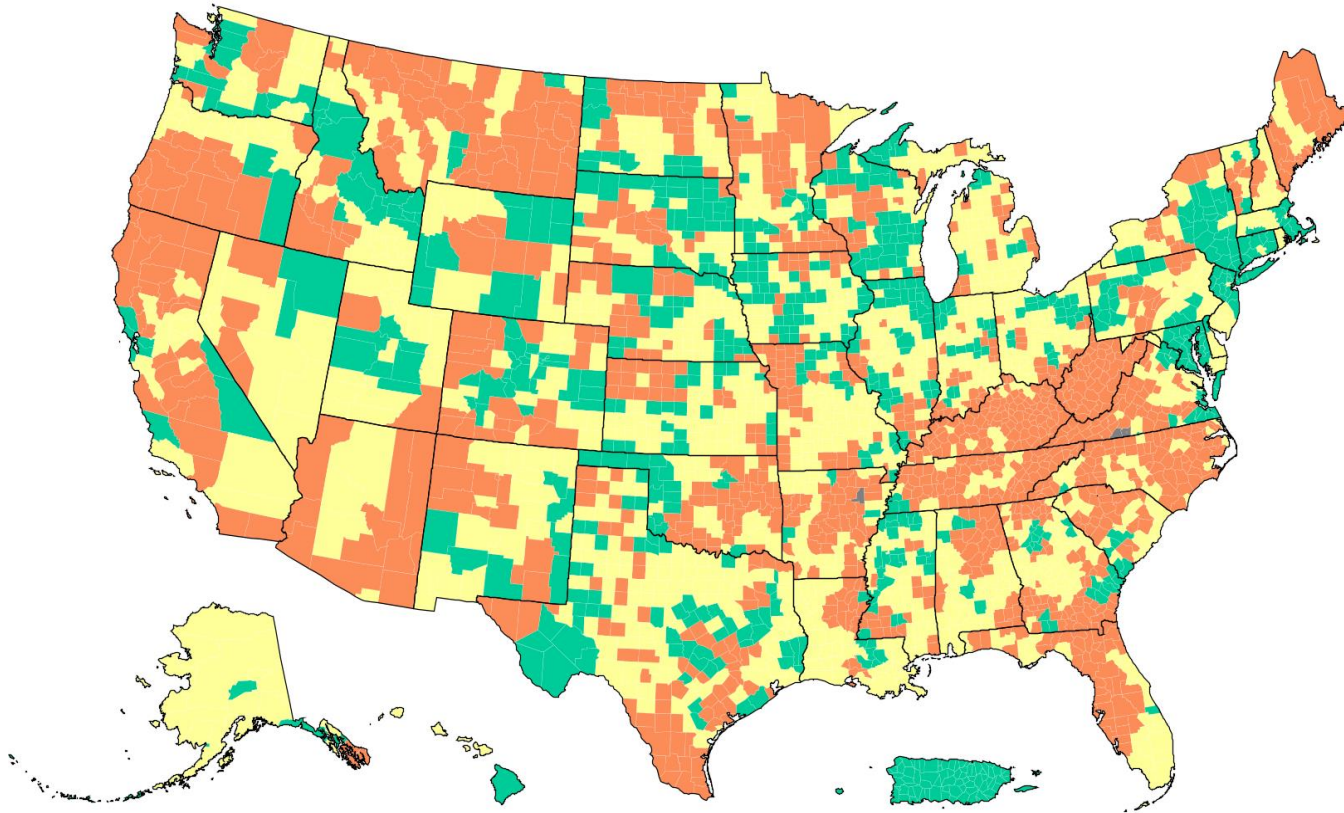

□ N/A
■ Low
■ Medium
■ High

	% of Counties	% of Pop.
Low	23.0%	29.5%
Medium	39.6%	42.2%
High	37.3%	28.2%

Data sources and acknowledgments

- **Data sources**

- Unified Hospital Data Surveillance System (UHDSS)
- Aggregate Case and Death Counts (ACDC)

- **Acknowledgments**

- Johns Hopkins University's Applied Physics Laboratory
- CDC COVID-19 Response

Agenda Summary GRAND COUNTY COMMISSION March 1, 2022 AGENDA ITEM: C	
TITLE:	LUC Updates prioritization
FISCAL IMPACT:	N/A
PRESENTER(S):	Planning & Zoning Staff

Prepared By: <i>ELISSA MARTIN</i> GRAND COUNTY PLANNING & ZONING

FOR OFFICE USE ONLY:

Attorney Review: <p style="text-align: center;">N/A</p>

LUC Updates Spring 2022

P&Z Staff is currently seeking the Commission’s direction in prioritizing the following code updates:

- 1) **Article 3 Use Regulations**
 - a) **Section 3.3.2 ADU’s** – updates per Utah state code requirements, to address Internal ADU’s and setbacks for External ADU’s. And Consider allowing an additional IADU along with one detached EADU on a parcel.
 - b) **Section 3.3.3 Standards for Temporary Uses** – update to include regulations for special permits (Music Festivals, Flea Markets, pop up restaurants, art fairs, etc..)
- 2) **Section 4.6 OAO** (Draft redlined copy of this section is ready for review).
 - a) Streamline and clarify the permitting process and requirements for each stage of development application (District Application and Site Plan Review).
 - b) Replace the Dude Ranch category with a “Special Purpose Retreat” category (educational, art, wellness retreats) for small scale glamping developments.
 - c) Include requirement for parcels over 10 acres to provide a conservation easement on sensitive lands (including scenic viewsheds).
- 3) **Article 4 & 6 Housing Solutions**
 - a) Revise Section 6.14 Assured Housing and 6.15 Affordable Housing Requirements. Establish ordinance to require all new development to pay for affordable housing (based on Summit County model), or potentially apply a relatively small percentage surcharge or impact fee for all building permits across the board (more research needed).
 - b) Planning Commission and members of Commission have expressed interest in allowing long-term rental RV and/or tiny home

developments in limited areas to house seasonal workers as well as long term residents. Possible Special Purpose Overlay District similar to HDHO with a sunset date, a maximum unit cap and eligible parcels map.



**GRAND COUNTY
COMMISSION REGULAR MEETING**

**Grand County Commission Chambers
Held virtually on Zoom
Moab, Utah**

WATCH ON YOUTUBE - search for: "GRAND COUNTY UTAH GOVERNMENT"

**MINUTES
15 February, 2022**

The Grand County Commission met in a regular meeting on February 15th, 2022. The meeting was streamed/attended electronically. It was also broadcast and saved on YouTube. Attending the meeting were Grand County Commissioners Clapper, Hadler, Hedin, McGann, Stock, Walker. For the joint Planning Commission portion of the meeting Grand County Planning Commission members Campbell, O'Brien, Evers, Barkley and Makeda attended. Also present were Grand County Commission Administrator Mallory Nassau and Clerk/Auditor Quinn Hall.

2:00 pm Call to Order

Chair Woytek called the meeting to order at 2:02 pm

Joint Workshop with Grand County Planning Commission

General Business- Action Items- Discussion and Consideration of:

Land Use Scenario Planning:

- 1) Timetable and deliverables (John Guenther, Planning & Zoning Director)
- 2) Presentation on scenarios and decision points (Bill Grimes, SCJ Alliance)
- 3) Section breakdown and roundtable discussion
- 4) Closing and summary (John Guenther, Planning & Zoning Director and Bill Grimes, SCJ Alliance)

Commission Chair Woytek turned the time over to John Guenther from planning and zoning. John discussed the timetable and deliverables, noting the anticipated completion dates of various aspects of the plan.

Bill Grimes discussed the Grand County General Plan. Bill discussed the planning process and explained different strategies. Bill addressed the importance of a shared vision and well-defined goals. Bill explained the difference between vision based planning and scenario based planning. Bill discussed events that may or may not influence the planning process. Bill discussed some different scenarios that may influence future planning efforts, and potential responses addressed through proper planning.

Bill discussed the importance of defining direction and adjusting responses to address unexpected changes in direction. Bill discussed the public workshop and explained how it should play out, expected responses, and potential responses and planning goals.

Bill and John discussed the goal of becoming familiar with the planning process and potential scenarios so commissioners are comfortable with the process. Bill reiterated the three scenarios and suggested the commissioners attempt to match up the scenarios to the planning process.

John discussed levels of service and infrastructure and the importance of fleshing out those ideas and ideals in the land use code. John noted the purpose is to get the land use code to support the general plan and create consistency and a clear path to the future.

Bill discussed the best methods for attempting to decipher the future and participating in the planning process. John asked the commission to weigh in and offer and suggestions or comments.

Mary suggested she'd like some help drilling down into the details of the process.

Evan noted the collective bodies may be suffering from analysis paralysis and noted he'd like to potentially see the process move more quickly. Evan suggested planning and zoning and the commission could take some decisive, immediate actions to alleviate perceived roadblocks in the planning process.

Bob suggested potentially combining some of the areas to ease the process.

Emily suggested putting the video and process on Grand County Connects so the planning commission can direct citizens there for engagement.

Gabe offered thanks for all the efforts and adjourned the meeting at 3:25 pm.

Thompson Springs Special Service Fire District Board Meeting (see separate minutes)

Grand County Commission Meeting 4:06 pm – all commissioners present

Citizens to Be Heard (and again at approximately 6:00 pm)

(none at this time)

Department Reports (approximately 15 minutes per report) (none at this time)

Agency Reports (approximately 15 minutes per report) (none at this time)

Approval of Minutes (Quinn Hall, Clerk/Auditor)

- A. February 1, 2022 (Regular County Commission Meeting)
- B. February 8, 2022 (Grand County Commission, Moab City Council & San Juan County Commission Special Joint Workshop)

Motion by Mary McGann to approve the minutes form 1 February and 8 February, 2022.

Motion seconded by Jacques Hadler

Discussion (none at this time)

Motion passes 7-0

Ratification of Payment of Bills

Motion by Kevin Walker to approve and ratify bills in the amount of \$597,137.43 and payroll in the amount of \$294,937.22 for a combined total of \$892,074.65

Motion seconded by Jacques Hadler

Discussion (none at this time)

Motion passes 7-0

Commission Member Disclosures (none at this time)

General Commission Reports and Future Considerations

Trish Hedin

- Grand Water and Sewer meeting
- Joint Meeting with Grand County, Moab City, and San Juan County
- Conservation meeting
- Meeting at Old Spanish Trail Arena (OSTA)
- Local Homeless Council meeting
- Planning Commission meeting

Mary McGann

- Uranium Mill Tailings Remedial Action (UMTRA) moved 300,000 tons of tailings
- Met with Utah State University
- Airport board meeting
- Moab Area Housing Task Force meeting
- Met with new lobbyist

Jacques Hadler

- Met with Trail Mix
- Thompson Springs water district meeting
- Motorized Trail Committee meeting

Kevin Walker

- Met with legislation committee
- Joint meeting with San Juan County, Moab City, and Grand County

Evan Clapper

- Joint Planning Commission meeting
- Attended Boundary Commission meeting
- Cemetery Board meeting

Sarah Stock

- Community Renewable Energy Program meeting
- Met with new lobbyist
- Met with Moab Mosquito Abatement (MMAD)
- Joint City, County, San Juan County meeting

Gabriel Woytek

- Canyonlands Business Summit
- Canyonlands Healthcare Special Service District meeting
- Housing Task Force meeting

Elected Official Reports

Commission Administrator Report

Mallory announced that Quinn Hall had accepted the position of Associate Commission Administrator. The Clerk/Auditor position will be advertised this week.

Presentations (approximately 15 minutes per presentation)

- C. Presentation on the Department of Wildlife Resources (DWR) annual PILT payment and update on DWR's activities within the county (Chris Wood, DWR Regional Supervisor)

Chris Wood discussed the annual PILT payment, noting the check is in the mail for the Payment in Lieu of Taxes (PILT) payment. The DWR owns two parcels in the County, and pays the county in lieu of taxes. Chris discussed the role of the DWR and offered thanks to the county for a good working relationship.

Trish offered thanks. Mary offered thanks as well.

- D. Presentation on Regional Water Consortium and Working Group (John Guenther, Planning & Zoning Director)

John Guenther discussed the Regional Water Consortium, noting the importance of the group and explaining some of their efforts to identify available water resources and evaluation and protection of resources. Dana Van Horn (GWSSA) discussed the study and explained the purpose and end goal of the plan. Dana discussed the need for Grand County to be the legislative body. Dana discussed the MOU, noting it's only for the districts, but the County may be more involved in the future.

General Business- Action Items- Discussion and Consideration of:

- E. Approving contract agreement with Emery Telcom for six video segments for Responsible Recreation messaging (Andrea Brand, Sand Flats Recreation Area Director)

Presentation

Andrea discussed the agreement for the videos, noting this is an extension of the prior agreement and the inclusion of some edited videos with changes, including additions of biological soil crusts language and information.

Motion by Jacques Hadler approve the Emery Telcom Agreement for six video segments on ETV CHANNEL 6 and authorize the Chair to sign the Contract Agreement. The terms of this agreement include \$900 per month for six video segments on ETV CHANNEL 6 for the term of 10 months to run March 2022 through December 2022.

Motion seconded by Kevin Walker

Discussion

Kevin suggested support and noted the changes are improvements.

Motion passes 6-0-1 Stock abstains

- F. Approving the county as the "Responsible Entity" for the HUD Environmental Review for the Housing Authority of Southeastern Utah (HASU) SHOP grant project (Jenna Whetzel, HASU Program Manager)

Presentation

Mallory discussed the SHOP grant offered to HASU, but noted they need a HUD environmental review first. Grand County will need to be the lead entity to facilitate the review. The county would need to sign off on two letters stating there is no environmental impact that can't be successfully mitigated.

Motion by Trish Hedin to approve Grand County as the "Responsible Entity" for the HUD Environmental Review for the Housing Authority of Southeastern Utah SHOP grant project.

Motion seconded by Jacques Hadler

Discussion (none at this time)

Motion passes 7-0

- G. Adopting Resolution Approving the Final Condominium Plat and Subdivision Improvements Agreement for Murphy Flats, Phase II, an HDHO Development located at 1187 Murphy Lane, Parcel No. 02-0008-0097 (Planning & Zoning)

Presentation

Elissa Martin discussed the final plat for Murphy Flat, including deed restrictions, number of units and other details. Kevin asked about the widening of Murphy Lane, noting the new construction on the other side of the road. Courtney Kizer (developer) noted the hill would not be changed now.

Motion by Jacques Hadler to adopt the Findings of Fact set forth in the Staff Report dated December 14, 2021 and the proposed Resolution approving the Final Condominium Plat and Subdivision Improvements Agreement for Murphy Flats, Phase II, an HDHO Development with the following conditions:

1. Continued compliance with the County Engineer's requirements, Ordinance No. 648, HDHO-15 Master Plan and related Development Agreement, as amended;
2. The Owner shall record the SIA simultaneously with the Final Plat in the Recorder's Office; and
3. The Owner shall submit an acceptable completion assurance bond for the incomplete public improvements and infrastructure warranty bond for completed accepted public improvements as established in the SIA to the County in the amounts set forth in the SIA prior to recordation of the Final Plat.
4. The existing ADU must be demolished and the recorded deed restriction (August 14, 2015 as Entry No. 509461 in Book 821, Page 583-84) must be terminated prior to issuance of the first building permit in Phase II.

Motion seconded by Mary McGann

Discussion (none at this time)

Motion passes 7-0

- H. Adopting Ordinance approving the Entrada Overnight Accommodations Overlay- Campground rezone for Parcel No. 24-0XST-0067, located off SR 313 (Planning & Zoning)

Presentation

Elissa discussed the overnight accommodations overlay and noted one correction from the staff report, noting the development is for a luxury camping site with 16 tent sites and various amenities. Elissa noted the applicant's desire to create a conservation easement.

Trish noted the inability of the county to assure either a conservation agreement or employee housing.

Christina discussed the difference between a minor vs major agreement modification. Christina noted the only way to approve those stipulations is through a development agreement that goes through the public hearing process.

Trish suggested hesitancy to support without agreements in place to assure employee housing.

Kevin asked about the extent of the changes needed in the development agreement.

Mary noted the potential low impact of the project and noted the desire of the commission to find unique projects that help the community. Mary suggested support, but noted she'd like to see stipulations added or some form of guarantee for so the county is protected.

Kevin noted the motion could be modified slightly to include some changes.

Matt Kareus (developer) offered thanks to the commission and described the project, noting his desire to create a destination with minimal impact to both the landscape and county.

Christina noted that postponing it could dramatically increase the timeline.

Motion by Trish Hedin to deny the Overnight Accommodations Overlay–Campground rezone and associated Master Plan attached hereto as Exhibit A and OAO Development Agreement for Grand County Parcel No. 24-0XST-0067.

Motion seconded by Jacques Hadler

Discussion

Trish noted she'd be more likely to support a local developer with money coming into vs. leaving the community. Trish noted potential water usage concerns.

Kevin noted the ability, and support, to approve a modified version of the proposal if presented. Kevin discussed the small area plan that was created for the 191/313 area. Kevin suggested that some development in the area is likely inevitable, and a small camping area could be appropriate. Kevin noted the ability to develop the area with many more houses if the Range and Grazing zoning is left intact. Kevin suggested that a proposal with easements and guarantees could be seen as favorable. Kevin noted the county has dramatically slowed overnight accommodations in the last 3 years. Kevin discussed the historical applications for campgrounds in the area, but noted the different nature of the proposed campground. Kevin noted the approval is only for what is in the master plan, and not for increased density or construction. Kevin suggested a straw poll to gauge commission interest in approving a plan with easements included.

Christina noted the commission should consider and make findings regarding approval or denial.

Jacques Hadler suggested he agrees with Trish, but noted he'd reconsider if there were an assurance of employee housing and a conservation agreement.

Mary noted the potential for the parcel to developed to a degree that would be much more onerous to the county and citizens is likely high if this application is denied. Mary suggested support – if there are easements and assurances in place.

Evan noted he'd like to see the ratio of OAO and housing be more in line with the county's long term goals before any more OAO's are approved.

Sarah suggested that the development agreement needs to be clearer and the process should start over an incorporate those assurances before approving, but that if the assurance were in place, she may be supportive.

Trish reiterated the need for the ratio of housing to OA's to be kept stable.

Gabriel expressed concern over the OA's vs housing ratio. Gabriel suggested he's against approving any more OA's before more affordable housing.

Kevin discussed the likelihood of other developments coming in or perhaps the state legislature stepping in and forcing the county's hand to approve more developments in the face of Grand County's continued denials of overnight accommodations. Kevin suggested it could benefit the county to show some flexibility.

Mary noted support for Kevin's comments and suggested the development has the potential to protect a large area of land.

Trish noted the ratio is perhaps not the only component, but that public comment was overwhelmingly against the development.

Gabe noted Stock, Hadler, McGann, and Walker may be in favor of reworking the agreement and possible approval.

Substitute Motion by Kevin Walker to amend the motion to deny by adding:

- a. Grand County's ratio of overnight accommodation units to one primary residential unit is currently at 1.7, which is higher than the 2019 baseline of 1.4 [if approving, justify need/desire for OA despite worsening housing crisis];
- b. A carrying capacity analysis or additional studies specific to Grand County's capacity to support further overnight accommodation has not been complete
- c. Findings discussed in commission deliberations.

Motion seconded by Mary McGann

Motion to amend passes 6-0-1. Trish, yes. Jacques, yes. Mary, yes, Kevin, yes. Sarah, yes. Gabe, yes. 6-0-1 Clapper absent.

Discussion

Kevin noted he hopes this comes back in modified form

Amended motion passes 5-1-1 Hedin, yes. Hadler, yes. McGann, nay. Walker, Yes, Stock, Yes. Gabe, yes. Clapper absent. McGann against, Clapper absent.

Citizens to be heard (6:00 pm) (none at this time)

- I. Adopting Ordinance approving the Amended and Restated Development Agreement for Viewgate Terrace Phase II Final Plat, an HDHO development (Planning & Zoning)

Presentation

Elissa discussed the extension and the development agreement.

Motion by Kevin Walker to adopt the ordinance approving the proposed Amended and Restated Development Agreement for Viewgate Terrace HDHO development with the following condition:

- a. The Owner shall record the Development Agreement in the real property records of Grand County simultaneously with this Ordinance and prior to application for further site plan, construction, or development approvals.

Motion seconded by Mary McGann

Discussion (none at this time)

Motion passes 6-0-1 Clapper absent

- J. Approving Memorandum of Understanding (MOU) between the County and City of Moab Planning Commissions (John Guenther, Planning & Zoning Director)

Presentation

John Guenther discussed the MOU, noting broad support to formalize an agreement to facilitate a better working relationship.

Motion by Mary McGann to approve the Memorandum of Understanding (MOU) regarding mutual regional planning between the City of Moab and Grand County.

Motion seconded by Kevin Walker

Discussion

Kevin offered his thanks and noted support for better collaboration going forward.

Motion passes 6-0-1 Clapper absent

- K. Approving Special Event Permit for the 2022 Jeep Safari at Old Spanish Trail Arena (OSTA) (Angie Book, OSTA Director)

Presentation

Angie Book discussed the 2022 Jeep Safari. Angie noted this would be the 56th year of the annual Jeep Safari.

Motion by Trish Hedin approve the 2022 Easter Jeep Safari Special Event Permit.

Motion seconded by Kevin Walker

Discussion (none at this time)

Motion passes 6-0-1 Clapper absent

- L. Approving Special Event Permit for Cruise Moab at Old Spanish Trail Arena (OSTA) (Angie Book, OSTA Director)

Presentation

Angie discussed the event for Toyota Land Cruisers, noting it's similar to Jeep Safari but smaller.

Motion by Trish Hedin to approve the 2022 Cruise Moab Special Event Permit.

Motion seconded by Jacques Hadler

Discussion (none at this time)

Motion passes 6-0-1 Clapper absent

- M. Approving the Special Event Advisory Committee as the Approval Authority for the 2022 Fallen Peace Officer Special Event Permit (Angie Book, OSTA Director)

Presentation

Angie discussed the appointment of the SEAC as the advisory committee. Angie noted this is a recurring event with a family dinner. Angie noted they would use ATV's/UTV's. Christina noted this would be illegal to approval – against the formerly adopted moratorium. Angie noted there have been some communications between the event sponsor but the arena, but they hadn't progressed recently.

Motion by Mary McGann to approve the Special Event Advisory Committee as the Approval Authority for the 2022 Fallen Peace Officer special event permit, with the understanding that full size vehicles shall be used in place of ATV's/UTV's

Motion seconded by Trish Hedin

Discussion

Kevin discussed alternate methods of approval, noting the moratorium would need to be lifted before approval. Mary noted support and approval of the event, but also support for the citizens of Grand County and the moratorium. Jacques asked about the Fallen Peace Officer trail, and Mary suggested it's likely suitable for full size vehicles.

Gabe suggested it's perhaps too late to impose restrictions on the event. Gabe suggested supporting this could go a long way to supporting the law enforcement community. Christina noted the organizer has likely known about the ATV moratorium for over a year. Christina noted upcoming legislation that would limit the ability of the county to permit and regulate ATV's, and any deviation could pose a legal conundrum to the county.

Sarah noted support for the moratorium, and the event.

Kevin asked about the potential to carve out exceptions, and the potential to harm the prior moratorium.

Mary suggested the potential to require a trailering stipulation to the special event permit. Angie noted the majority of ATV's/UTV's are likely trailered to the event.

Motion passes 5-1 Woytek opposed

- N. Approving the Special Event Advisory Committee as the Approval Authority for the 2022 Team Rubicon Special Event Permit (Angie Book, OSTA Director)

Presentation

Angie described the Team Rubicon event, noting this, again, would give the SEAC approval authority. Angie described the event and its components. Angie noted there are several different entities participating in the event. Angie noted this is not an ATV/UTV event.

Motion by Kevin Walker to approve the Special Event Advisory Committee as the Approval Authority for the 2022 Team Rubicon special event permit

Motion seconded by Mary McGann

Discussion

Mary noted she's excited to see this happen after prior postponements.

Motion passes 6-0-1 Clapper absent

- O. Approving the Commission's Community Impact Fund Board (CIB) prioritized project list for the Grand County local government prioritization process meeting (Mallory Nassau, Commission Administrator)

Presentation

Mallory discussed the CIB ranking list, noting this is just for the commissioner attending the meeting. The projects will actually be ranked again by the CIB after the meeting.

Motion by Trish Hedin to approve the Commission's Community Impact Fund Board (CIB) prioritized project list for the Grand County local government prioritization process meeting.

Motion seconded by Mary McGann

Discussion (none at this time)

Motion passes 6-0-1 Clapper absent

- P. State Legislative Updates (Christina Sloan, County Attorney)

Presentation

Christina discussed the House and Senate Bills. Christina discussed some efforts to limit a county's ability to regulate ATV's, eBike usage, overnight rentals being advertised online, elections bills, transportation measures, the death penalty, etc.

Gabriel discussed supporting housing funding letter and appropriations.

Motion by Mary McGann to oppose House Bills 323, 324 and 371 and Senate Bills 51 and 179 support House Bill 372, and support the appropriation of funding for affordable housing, and authorize the Chair to sign any necessary letters of opposition or support to Utah legislators deemed necessary by the County Legislative Committee or County Attorney.

Motion seconded by Jacques Hadler

Discussion (none at this time)

Motion passes 6-0-1 Clapper absent

- Q. Approving Tolling Agreement with Peak View Development, LLC for Moab District Court Case No. 210700044 (Christina Sloan, County Attorney)

Presentation

Christina discussed the settlement and explained the implications, noting it would be dismissed without prejudice. Christina noted this is not approval of an amended plan.

Motion by Kevin Walker to approve the Tolling Agreement with Peak View Development, LLC for Moab District Court Case No. 210700044.

Motion seconded by Jacques Hadler

Discussion (none at this time)

Motion passes 6-0-1 Clapper absent

- R. Approving Notice of Vacancy and Intent to Appoint a Replacement for the Clerk/Auditor (Christina Sloan, County Attorney)

Presentation

Christina discussed vacancy for the Clerk/Auditor position.

Motion by Mary McGann to approve the notice of vacancy and intent to appoint a replacement for the Clerk/Auditor.

Motion seconded by Trish Hedin

Discussion (none at this time)

Motion passes 7-0

Consent Agenda- Action Items

- S. Ratifying local consent for Red Cliffs Lodge's Package Agency, Off-Premise Beer, Banquet Liquor, and Full- Service Restaurant Liquor License applications through the Dept. of Alcohol and Beverage Commission
- T. Ratifying the Chair's signature on an Independent Contractor Agreement with NES, Inc. for lobbying activities
- U. Approving Chair's signature on a sign-on letter to the Manti-La Sal National Forest requesting a presentation to local governments and public regarding research on mountain goat impacts on the alpine area of the La Sal Mountains
- V. Approving Emergency Medical Dispatch Program Purchase
- W. Approving a purchase agreement with Sphere Plus Corporation for a touchless on-demand parking platform at the Canyonlands Regional Airport

X. Approving letter of support to the Utah Office of Outdoor Recreation Grant Program Pack Creek footbridge

Presentation

Motion by Jacques Hadler to adopt the consent agenda as presented.

Motion seconded by Kevin Walker

Discussion (none at this time)

Motion passes 7-0

Discussion Items

Y. Calendar items and special events (Mallory Nassau, Commission Administrator)

Mallory noted we're closed President's Day. Special Events are ramping up. Many are repeat events. Several running events, biking events, etc.

Public Hearings- Possible Action Items (none at this time)

Closed Session(s) (if necessary)

Motion by Jacques Hadler to enter closed session for the purposes of discussing the character, professional competence, or physical or mental health of an individual

Motion seconded by Trish Hedin

Motion passes 7-0

Commission entered closed session at 7:15 pm

Commission exited closed session at 8:07 pm

Chair Woytek adjourned the meeting at 8:08 pm.

Adjourn

GRAND COUNTY BILLS TO BE APPROVED

3/1/2022

113822-113877	A/P Checks	2/18/2022	\$444,000.18
113878-113882	A/P Checks	2/25/2022	\$223,927.46
33701-33708	Payroll Transmittals	2/20/2022	\$33,107.14
22822101-22822108	Payroll Transmittals	2/20/2022	\$444,341.67

TOTAL BILLS **\$1,145,376.45**

33700			
22522101-22522292	02/07/22-02/20/22	2/25/2022	\$299,557.73

TOTAL PAYROLL **\$299,557.73**

TOTAL BILLS & PAYROLL **\$1,444,934.18**

113834 GRAND COUNTY REC. SPECIAL SER. DIST.	\$137,000.00 YOUTH SPORTS
113836 HOGAN & ASSOCIATES CONSTRUCTION	\$101,138.11 GC EMS NEW BUILDING
113840 JONES & DEMILLE ENGINEERING INC	\$33,768.34 GC EMS NEW BUILDING
113847 MOAB AREA COMMUNITY LAND TRUST	\$91,200.00 SALARY FOR KAITLIN MYERS
113856 NICHOLAS & COMPANY	\$10,847.46 JAIL/INMATE FOOD
113863 ROCKY MOUNTAIN POWER	\$14,382.17 VARIES COUNTY ELECTRIC BILL
113876 HOODOO MOAB	\$15,929.60 BUSINESS SUMMIT
113879 GARLAND/DBS, INC	\$102,039.96 NEW ROOF FOR GRAND CENTER
113882 UTAH STATE DIV. OF FINANCE	\$118,000.00 LOAN PAYMENT ON EMS BUILDING
	\$624,305.64

Report Criteria:

Detail report.

Invoices with totals above \$0 included.

Paid and unpaid invoices included.

Vendor.Last Check Number = 113822-113877

Last Check Number	Vendor	Vendor Name	Invoice Number	Description	Net Invoice Amount	Amount Paid	Date Paid
AJOULES, INC							
113822	34304	AJOULES, INC	10102-2022	CLERK	750.00	750.00	02/18/2022
113822	34304	AJOULES, INC	10102-2022	TREASURER	750.00	750.00	02/18/2022
113822	34304	AJOULES, INC	10102-2022	ASSESSOR	750.00	750.00	02/18/2022
113822	34304	AJOULES, INC	10102-2022	RECORDER	750.00	750.00	02/18/2022
Total AJOULES, INC:					3,000.00	3,000.00	
ARDALAN, NADI							
113823	33653	ARDALAN, NADI	01092022	SAR MILEAGE REIMBURSEMEN	28.08	28.08	02/18/2022
113823	33653	ARDALAN, NADI	02062022	SAR MILEAGE REIMBURSEMEN	140.99	140.99	02/18/2022
Total ARDALAN, NADI:					169.07	169.07	
BRAND MARKERS							
113824	36898	BRAND MARKERS	103104-1	GC ECONOMIC DEVELOPMENT	875.60	875.60	02/18/2022
Total BRAND MARKERS:					875.60	875.60	
CANYONLANDS AUTO							
113825	12515	CANYONLANDS AUTO	622462	ROAD	36.04	36.04	02/18/2022
113825	12515	CANYONLANDS AUTO	622729	ROAD	44.98	44.98	02/18/2022
113825	12515	CANYONLANDS AUTO	623024	sheriff	146.28	146.28	02/18/2022
113825	12515	CANYONLANDS AUTO	623161	sheriff	117.34	117.34	02/18/2022
113825	12515	CANYONLANDS AUTO	623958	ROAD	5.24	5.24	02/18/2022
113825	12515	CANYONLANDS AUTO	624164	ROAD	63.12	63.12	02/18/2022
113825	12515	CANYONLANDS AUTO	622969	sheriff	105.31	105.31	02/18/2022
113825	12515	CANYONLANDS AUTO	623132	ROAD	29.98	29.98	02/18/2022
113825	12515	CANYONLANDS AUTO	623944	sheriff	12.75	12.75	02/18/2022
113825	12515	CANYONLANDS AUTO	624018	sheriff	29.22	29.22	02/18/2022
113825	12515	CANYONLANDS AUTO	523272	CEMETERY	7.49	7.49	02/18/2022
113825	12515	CANYONLANDS AUTO	623502	ROAD	277.85	277.85	02/18/2022
113825	12515	CANYONLANDS AUTO	623967	sheriff	6.81	6.81	02/18/2022
113825	12515	CANYONLANDS AUTO	624085	sheriff	23.12	23.12	02/18/2022
113825	12515	CANYONLANDS AUTO	624130	ROAD	31.22	31.22	02/18/2022
113825	12515	CANYONLANDS AUTO	622447	ROAD	265.00	265.00	02/18/2022
113825	12515	CANYONLANDS AUTO	622678	ROAD	169.44	169.44	02/18/2022
113825	12515	CANYONLANDS AUTO	624018	ROAD	230.65	230.65	02/18/2022
113825	12515	CANYONLANDS AUTO	622437	sheriff	23.99	23.99	02/18/2022
113825	12515	CANYONLANDS AUTO	622564	SANDFLATS	16.49	16.49	02/18/2022
113825	12515	CANYONLANDS AUTO	622588	ROAD	245.18	245.18	02/18/2022
113825	12515	CANYONLANDS AUTO	622733	ROAD	608.57	608.57	02/18/2022
113825	12515	CANYONLANDS AUTO	623055	sheriff	69.97	69.97	02/18/2022
113825	12515	CANYONLANDS AUTO	622708	ROAD	445.67	445.67	02/18/2022
113825	12515	CANYONLANDS AUTO	622406	ROAD	145.30	145.30	02/18/2022
113825	12515	CANYONLANDS AUTO	622590	ROAD	25.28	25.28	02/18/2022
113825	12515	CANYONLANDS AUTO	622736	ROAD	1.01	1.01	02/18/2022
113825	12515	CANYONLANDS AUTO	623062	AIRPORT	32.16	32.16	02/18/2022
113825	12515	CANYONLANDS AUTO	623647	ROAD	26.08	26.08	02/18/2022
Total CANYONLANDS AUTO:					2,348.18	2,348.18	

Last Check Number	Vendor	Vendor Name	Invoice Number	Description	Net Invoice Amount	Amount Paid	Date Paid
CASTLE COUNTRY HYDRAULIC & SUPPLY							
113826	36709	CASTLE COUNTRY HYDRAULIC	135568	ROAD	50.00	50.00	02/18/2022
Total CASTLE COUNTRY HYDRAULIC & SUPPLY:					50.00	50.00	
CDW GOVERNMENT INC.							
113827	12830	CDW GOVERNMENT INC.	Q442526	SHERIFF/WD 5TB MY PASSPOR	239.32	239.32	02/18/2022
113827	12830	CDW GOVERNMENT INC.	R762689	ASSESSOR/KEYBOARD, MOUS	256.67	256.67	02/18/2022
Total CDW GOVERNMENT INC.:					495.99	495.99	
CENTURY EQUIPMENT COMPANY, INC							
113828	12900	CENTURY EQUIPMENT COMPA	GP13691	ROAD	1,081.89	1,081.89	02/18/2022
Total CENTURY EQUIPMENT COMPANY, INC.:					1,081.89	1,081.89	
CHINOOK MEDICAL GEAR, INC							
113829	36856	CHINOOK MEDICAL GEAR, INC	0105038	SHERIFF/JAIL	1,750.29	1,750.29	02/18/2022
Total CHINOOK MEDICAL GEAR, INC:					1,750.29	1,750.29	
DIRECTV							
113830	31998	DIRECTV	080449209X22	SHERIFF	163.63	163.63	02/18/2022
Total DIRECTV:					163.63	163.63	
FITZGERALD LAW OFFICE LLC							
113831	32643	FITZGERALD LAW OFFICE LLC	FEB 2022	JUVENILE COURT PUBLIC DEF	4,250.00	4,250.00	02/18/2022
113831	32643	FITZGERALD LAW OFFICE LLC	FEB 2022	OFFICE SUPPLIES	83.33	83.33	02/18/2022
Total FITZGERALD LAW OFFICE LLC:					4,333.33	4,333.33	
FRONTIER							
113832	15810	FRONTIER	FEB 2022	e911-435-196-1354	94.12	94.12	02/18/2022
113832	15810	FRONTIER	FEB 2022	e911-435-196-1355	94.12	94.12	02/18/2022
Total FRONTIER:					188.24	188.24	
FRY,AARON							
113833	36010	FRY,AARON	02182022	CLOTHING REIMBURSEMENT	461.74	461.74	02/18/2022
Total FRY,AARON:					461.74	461.74	
GRAND COUNTY RECREATION SPECIAL SER. DIS							
113834	36629	GRAND COUNTY RECREATION	02142022	2022 YOUTH RECREATION MO	137,000.00	137,000.00	02/18/2022
Total GRAND COUNTY RECREATION SPECIAL SER. DIS:					137,000.00	137,000.00	
HANSEN, CATHERINE							
113835	36737	HANSEN, CATHERINE	02162022	MILEAGE	141.68	141.68	02/18/2022
113835	36737	HANSEN, CATHERINE	02162022	PER DIEM	108.00	108.00	02/18/2022
Total HANSEN, CATHERINE:					249.68	249.68	
HOGAN & ASSOCIATES CONSTRUCTION							
113836	35297	HOGAN & ASSOCIATES CONST	12	GRAND COUNTY MBA-EMS BUI	101,138.11	101,138.11	02/18/2022

Last Check Number	Vendor	Vendor Name	Invoice Number	Description	Net Invoice Amount	Amount Paid	Date Paid
Total HOGAN & ASSOCIATES CONSTRUCTION:					101,138.11	101,138.11	
HONNEN EQUIPMENT							
113837	32556	HONNEN EQUIPMENT	1345862	ROAD	107.00	107.00	02/18/2022
Total HONNEN EQUIPMENT:					107.00	107.00	
HOODOO MOAB							
113876	36380	HOODOO MOAB	83269 A	GRAND COUNTY BUSINESS SU	15,929.60	15,929.60	02/18/2022
Total HOODOO MOAB:					15,929.60	15,929.60	
INTELLIVEX							
113838	34862	INTELLIVEX	4175P-2	DISTPATCH/TOSHIBA 10kVA 160	3,920.00	3,920.00	02/18/2022
Total INTELLIVEX:					3,920.00	3,920.00	
JC TERMINATOR & SANITATION							
113839	36557	JC TERMINATOR & SANITATION	122	DISINFECTING & SANITATION	225.00	225.00	02/18/2022
113839	36557	JC TERMINATOR & SANITATION	1422	CARPET CLEANING FAMILY SU	1,288.00	1,288.00	02/18/2022
Total JC TERMINATOR & SANITATION:					1,513.00	1,513.00	
JONES & DEMILLE ENGINEERING INC							
113840	35417	JONES & DEMILLE ENGINEERI	0126664	1909-041.00 GC EMS	33,768.34	33,768.34	02/18/2022
Total JONES & DEMILLE ENGINEERING INC:					33,768.34	33,768.34	
KENWORTH SALES COMPANY							
113841	35364	KENWORTH SALES COMPANY	PRIIN4960567	ROAD	878.04	878.04	02/18/2022
113841	35364	KENWORTH SALES COMPANY	PRIIN4988974	ROAD	63.63	63.63	02/18/2022
113841	35364	KENWORTH SALES COMPANY	PRICM169665	ROAD	160.04-	160.04-	02/18/2022
113841	35364	KENWORTH SALES COMPANY	PRIIN4972723	ROAD	291.51	291.51	02/18/2022
113841	35364	KENWORTH SALES COMPANY	PRIIN4976676	ROAD	87.11	87.11	02/18/2022
Total KENWORTH SALES COMPANY:					1,160.25	1,160.25	
LAW ENFORCEMENT TARGETS, INC.							
113842	35091	LAW ENFORCEMENT TARGETS	0531189-IN	SHERIFF	427.47	427.47	02/18/2022
Total LAW ENFORCEMENT TARGETS, INC.:					427.47	427.47	
LEADSONLINE LLC							
113843	34756	LEADSONLINE LLC	324915	SHERIFF	1,881.06	1,881.06	02/18/2022
Total LEADSONLINE LLC:					1,881.06	1,881.06	
MADBRO SPORTS							
113844	30957	MADBRO SPORTS	3081	SANDFLATS	650.20	650.20	02/18/2022
113844	30957	MADBRO SPORTS	3124	SEARCH & RESCUE	471.54	471.54	02/18/2022
Total MADBRO SPORTS:					1,121.74	1,121.74	
MEADOR, JARED							
113845	36279	MEADOR, JARED	01092022	SAR MILEAGE REIMBURSEMEN	22.82	22.82	02/18/2022

Last Check Number	Vendor	Vendor Name	Invoice Number	Description	Net Invoice Amount	Amount Paid	Date Paid
Total MEADOR, JARED:					22.82	22.82	
MENDONCA, FRANK							
113846	32590	MENDONCA, FRANK	01232022	SAR MILEAGE REIMBURSEMEN	18.14	18.14	02/18/2022
113846	32590	MENDONCA, FRANK	02062022	SAR MILEAGE REIMBURSEMEN	15.21	15.21	02/18/2022
Total MENDONCA, FRANK:					33.35	33.35	
MOAB AREA COMMUNITY LAND TRUST							
113847	36865	MOAB AREA COMMUNITY LAND	102	MACLT EXECUTIVE DIRECTOR	91,200.00	91,200.00	02/18/2022
Total MOAB AREA COMMUNITY LAND TRUST:					91,200.00	91,200.00	
MOAB CHAMBER OF COMMERCE							
113848	20735	MOAB CHAMBER OF COMMER	3562	GC ECONOMIC DEVELOPMENT	40.00	40.00	02/18/2022
Total MOAB CHAMBER OF COMMERCE:					40.00	40.00	
MOAB FREE HEALTH CLINIC							
113849	34288	MOAB FREE HEALTH CLINIC	125	VISTA MEMBER 2021-2022	3,350.00	3,350.00	02/18/2022
Total MOAB FREE HEALTH CLINIC:					3,350.00	3,350.00	
MOAB HEAT N COOL, LLC							
113850	30302	MOAB HEAT N COOL, LLC	8664762	OSTA	182.00	182.00	02/18/2022
113850	30302	MOAB HEAT N COOL, LLC	8015802	OSTA	291.20	291.20	02/18/2022
Total MOAB HEAT N COOL, LLC:					473.20	473.20	
MOAB MUSIC FESTIVAL, INC							
113851	20890	MOAB MUSIC FESTIVAL, INC	02082022	STAR HALL DEPOSIT REFUND	210.00	210.00	02/18/2022
Total MOAB MUSIC FESTIVAL, INC:					210.00	210.00	
MOAB REGIONAL HOSPITAL							
113852	33329	MOAB REGIONAL HOSPITAL	96498-0002-00	PETERSEN, BRADLY	93.75	93.75	02/18/2022
113852	33329	MOAB REGIONAL HOSPITAL	48281-0017-00	FLORES-RIVERA, MARIO A.	93.75	93.75	02/18/2022
113852	33329	MOAB REGIONAL HOSPITAL	2970394-0112-	ZEILER, ROBERT	93.75	93.75	02/18/2022
113852	33329	MOAB REGIONAL HOSPITAL	96499-0001-00	LEVEQUE, DAVID	165.78	165.78	02/18/2022
113852	33329	MOAB REGIONAL HOSPITAL	80196-0006-00	CANTUA, OMAR A.	93.75	93.75	02/18/2022
113852	33329	MOAB REGIONAL HOSPITAL	96498-0001-00	PETERSEN, BRADLY	165.78	165.78	02/18/2022
113852	33329	MOAB REGIONAL HOSPITAL	77205-0016-00	CURTIS, JERRICA	65.96	65.96	02/18/2022
113852	33329	MOAB REGIONAL HOSPITAL	91566-0011-00	LORA, MATTHEW	93.75	93.75	02/18/2022
113852	33329	MOAB REGIONAL HOSPITAL	65276-0004-00	HULBERT, MICHAEL	125.46	125.46	02/18/2022
113852	33329	MOAB REGIONAL HOSPITAL	15986-0008-00	FARLEY, KEANU I.	125.46	125.46	02/18/2022
Total MOAB REGIONAL HOSPITAL:					1,117.19	1,117.19	
MOAB WASH & FOLD							
113853	35644	MOAB WASH & FOLD	112	OSTA/SHOP TOWELS	8.25	8.25	02/18/2022
Total MOAB WASH & FOLD:					8.25	8.25	
NAFTO							
113854	36136	NAFTO	10653	REGISTRATION/JAMISON WIGG	350.00	350.00	02/18/2022

Last Check Number	Vendor	Vendor Name	Invoice Number	Description	Net Invoice Amount	Amount Paid	Date Paid
Total NAFTAO:					350.00	350.00	
NEWMAN SIGNS							
113855	21760	NEWMAN SIGNS	TRFINV037326	ROAD DEPT SUPPLIES	2,263.37	2,263.37	02/18/2022
Total NEWMAN SIGNS:					2,263.37	2,263.37	
NICHOLAS AND COMPANY							
113856	21780	NICHOLAS AND COMPANY	7782848	JAIL	54.02	54.02	02/18/2022
113856	21780	NICHOLAS AND COMPANY	7790547	JAIL	223.69	223.69	02/18/2022
113856	21780	NICHOLAS AND COMPANY	7811689	JAIL	95.54	95.54	02/18/2022
113856	21780	NICHOLAS AND COMPANY	7782848	JAIL	1,459.75	1,459.75	02/18/2022
113856	21780	NICHOLAS AND COMPANY	7790547	JAIL	1,994.25	1,994.25	02/18/2022
113856	21780	NICHOLAS AND COMPANY	7804779	JAIL	297.12	297.12	02/18/2022
113856	21780	NICHOLAS AND COMPANY	7811689	JAIL	144.30	144.30	02/18/2022
113856	21780	NICHOLAS AND COMPANY	7798043	JAIL	332.29	332.29	02/18/2022
113856	21780	NICHOLAS AND COMPANY	7790547	JAIL	59.30	59.30	02/18/2022
113856	21780	NICHOLAS AND COMPANY	7811689	JAIL	1,785.45	1,785.45	02/18/2022
113856	21780	NICHOLAS AND COMPANY	7800588	JAIL	214.53	214.53	02/18/2022
113856	21780	NICHOLAS AND COMPANY	7798043	JAIL	2,848.10	2,848.10	02/18/2022
113856	21780	NICHOLAS AND COMPANY	7804779	JAIL	1,339.12	1,339.12	02/18/2022
Total NICHOLAS AND COMPANY:					10,847.46	10,847.46	
NORTH AMERICAN RESCUE, LLC							
113857	33332	NORTH AMERICAN RESCUE, LL	OR33178	REGISTRATION/AARON FRY	980.00	980.00	02/18/2022
Total NORTH AMERICAN RESCUE, LLC:					980.00	980.00	
OFFICE DEPOT, INC							
113858	22060	OFFICE DEPOT, INC	222353956001	ATTORNEY	144.31	144.31	02/18/2022
113858	22060	OFFICE DEPOT, INC	222514563001	ATTORNEY	41.84	41.84	02/18/2022
Total OFFICE DEPOT, INC:					186.15	186.15	
OFFICE ETC.							
113859	22070	OFFICE ETC.	482069	SHERIFF	50.00	50.00	02/18/2022
113859	22070	OFFICE ETC.	482069	CLERK	25.00	25.00	02/18/2022
113859	22070	OFFICE ETC.	482069	ASSESSOR	25.00	25.00	02/18/2022
113859	22070	OFFICE ETC.	482069	JUSTICE COURT	25.00	25.00	02/18/2022
113859	22070	OFFICE ETC.	482069	JAIL	50.00	50.00	02/18/2022
Total OFFICE ETC.:					175.00	175.00	
OFFICE OF STATE DEBT COLLECTION (OSDC)							
113860	36522	OFFICE OF STATE DEBT COLLE	2508	CASE#205002176-JESUS PERE	200.00	200.00	02/18/2022
Total OFFICE OF STATE DEBT COLLECTION (OSDC):					200.00	200.00	
PURE COUNTRY WATER							
113861	36090	PURE COUNTRY WATER	130565	CEMETERY	16.00	16.00	02/18/2022
Total PURE COUNTRY WATER:					16.00	16.00	
RIO ROJO DESIGN & SALES							
113862	33784	RIO ROJO DESIGN & SALES	01	GRAND CENTER	250.00	250.00	02/18/2022

Last Check Number	Vendor	Vendor Name	Invoice Number	Description	Net Invoice Amount	Amount Paid	Date Paid
Total RIO ROJO DESIGN & SALES:					250.00	250.00	
ROCKY MOUNTAIN POWER							
113863	27655	ROCKY MOUNTAIN POWER	FEB 2022	Grand Center/Senior	382.37	382.37	02/18/2022
113863	27655	ROCKY MOUNTAIN POWER	FEB 2022	AIRPORT	268.47	268.47	02/18/2022
113863	27655	ROCKY MOUNTAIN POWER	FEB 2022	WEED	26.40	26.40	02/18/2022
113863	27655	ROCKY MOUNTAIN POWER	FEB 2022	Road/Maint Shop	547.16	547.16	02/18/2022
113863	27655	ROCKY MOUNTAIN POWER	FEB 2022	OSTA	3,480.88	3,480.88	02/18/2022
113863	27655	ROCKY MOUNTAIN POWER	FEB 2022	EOC	485.37	485.37	02/18/2022
113863	27655	ROCKY MOUNTAIN POWER	FEB 2022	MMAD	105.60	105.60	02/18/2022
113863	27655	ROCKY MOUNTAIN POWER	FEB 2022	ROAD DEPT	360.46	360.46	02/18/2022
113863	27655	ROCKY MOUNTAIN POWER	FEB 2022	BLUE SKY LUMINARY	554.80	554.80	02/18/2022
113863	27655	ROCKY MOUNTAIN POWER	FEB 2022	CEMETERY DISTRICT	119.52	119.52	02/18/2022
113863	27655	ROCKY MOUNTAIN POWER	FEB 2022	COURTHOUSE	3,245.28	3,245.28	02/18/2022
113863	27655	ROCKY MOUNTAIN POWER	FEB 2022	MMAD/LIGHT	9.47	9.47	02/18/2022
113863	27655	ROCKY MOUNTAIN POWER	FEB 2022	WILLOW BASIN ROAD	223.10	223.10	02/18/2022
113863	27655	ROCKY MOUNTAIN POWER	FEB 2022	OSTA-BALL FIELD	10.10	10.10	02/18/2022
113863	27655	ROCKY MOUNTAIN POWER	FEB 2022	Grand Center/Civic	382.38	382.38	02/18/2022
113863	27655	ROCKY MOUNTAIN POWER	FEB 2022	Thompson Fire House	56.68	56.68	02/18/2022
113863	27655	ROCKY MOUNTAIN POWER	FEB 2022	AIRPORT FIRE TRUCK (AFF)	172.50	172.50	02/18/2022
113863	27655	ROCKY MOUNTAIN POWER	FEB 2022	ELGIN/Grand County Lights	597.89	597.89	02/18/2022
113863	27655	ROCKY MOUNTAIN POWER	FEB 2022	MUSEUM	125.77	125.77	02/18/2022
113863	27655	ROCKY MOUNTAIN POWER	FEB 2022	Sheriff	960.40	960.40	02/18/2022
113863	27655	ROCKY MOUNTAIN POWER	FEB 2022	OSTA-OUTDOOR ARENA	10.32	10.32	02/18/2022
113863	27655	ROCKY MOUNTAIN POWER	FEB 2022	AIRPORT	2,257.25	2,257.25	02/18/2022
Total ROCKY MOUNTAIN POWER:					14,382.17	14,382.17	
SADDLEBACK LIGHTING, INC							
113864	36244	SADDLEBACK LIGHTING, INC	48904	OSTA	199.90	199.90	02/18/2022
Total SADDLEBACK LIGHTING, INC:					199.90	199.90	
SALT LAKE COMMUNITY COLLEGE							
113865	31364	SALT LAKE COMMUNITY COLLEGE	2022.12.1	CADET MEALS	243.09	243.09	02/18/2022
Total SALT LAKE COMMUNITY COLLEGE:					243.09	243.09	
SAND SHEFF							
113866	36897	SAND SHEFF	02072022	BUSINESS SUMMIT/LUNCHTIME	350.00	350.00	02/18/2022
Total SAND SHEFF:					350.00	350.00	
SIMPLEVIEW							
113867	36078	SIMPLEVIEW	CI_14694	MOAB AREA TRAVEL COUNCIL	400.00	400.00	02/18/2022
113867	36078	SIMPLEVIEW	CI_14853	MOAB AREA TRAVEL COUNCIL	400.00	400.00	02/18/2022
Total SIMPLEVIEW:					800.00	800.00	
SOLLE, SCOTT							
113868	36222	SOLLE, SCOTT	02062022	SAR MILEAGE REIMBURSEMENT	49.73	49.73	02/18/2022
Total SOLLE, SCOTT:					49.73	49.73	
STATE FIRE SALES & SERVICE							
113869	29764	STATE FIRE SALES & SERVICE	INV000000514	CJC/CHRISTMAS BOX HOUSE	540.00	540.00	02/18/2022

Last Check Number	Vendor	Vendor Name	Invoice Number	Description	Net Invoice Amount	Amount Paid	Date Paid
Total STATE FIRE SALES & SERVICE:					540.00	540.00	
STATE OF UTAH DOPL							
113870	27520	STATE OF UTAH DOPL	DEC 2021	BLDG PERMIT OCT-DEC 2021	668.62	668.62	02/18/2022
Total STATE OF UTAH DOPL:					668.62	668.62	
TSOSIE, DERRICK							
113871	36896	TSOSIE, DERRICK	2510	RESTITUTION: CASE 211000339	150.00	150.00	02/18/2022
Total TSOSIE, DERRICK:					150.00	150.00	
UTAH OFFICE OF TOURISM							
113877	31600	UTAH OFFICE OF TOURISM	021622	MOAB AREA TRAVEL COUCIL/C	1,000.00	1,000.00	02/18/2022
Total UTAH OFFICE OF TOURISM:					1,000.00	1,000.00	
VIEVU, LLC							
113872	35337	VIEVU, LLC	VVSI-1002898	SHERIFF	208.00	208.00	02/18/2022
Total VIEVU, LLC:					208.00	208.00	
WEBSTER, JAMES							
113873	32650	WEBSTER, JAMES	01232022	SAR MILEAGE REIMBURSEMEN	17.55	17.55	02/18/2022
Total WEBSTER, JAMES:					17.55	17.55	
WHITE, STEVEN							
113874	28725	WHITE, STEVEN	03052022	PER DIEM	404.00	404.00	02/18/2022
Total WHITE, STEVEN:					404.00	404.00	
WITMER PUBLIC SAFETY GROUP, INC							
113875	36594	WITMER PUBLIC SAFETY GRO	E2156130	THOMPSON SPRINGS SPECIAL	130.12	130.12	02/18/2022
Total WITMER PUBLIC SAFETY GROUP, INC:					130.12	130.12	
Grand Totals:					444,000.18	444,000.18	

Date: March 1st 2022

County Auditor: _____

Council Chairperson: _____

Council: _____

Council: _____

Check No. _____

Last Check Number	Vendor	Vendor Name	Invoice Number	Description	Net Invoice Amount	Amount Paid	Date Paid
-------------------	--------	-------------	----------------	-------------	--------------------	-------------	-----------

Report Criteria:

Detail report.

Invoices with totals above \$0 included.

Paid and unpaid invoices included.

Vendor.Last Check Number = 113822-113877

Report Criteria:

- Detail report.
- Invoices with totals above \$0 included.
- Paid and unpaid invoices included.
- Vendor.Last Check Number = 113878-113882

Last Check Number	Vendor	Vendor Name	Invoice Number	Description	Net Invoice Amount	Amount Paid	Date Paid
CANYON COLOR GRAPHICS							
113878	30518	CANYON COLOR GRAPHICS	30	SANDFLATS 1ST HALF BIKE/4X	2,499.50	2,499.50	02/25/2022
Total CANYON COLOR GRAPHICS:					2,499.50	2,499.50	
GARLAND/DBS, INC.							
113879	36899	GARLAND/DBS, INC.	42785237499	25-UT-201064/GRAND CENTER	102,039.96	102,039.96	02/25/2022
Total GARLAND/DBS, INC.:					102,039.96	102,039.96	
HONOUR, JOSHUA C.							
113880	34409	HONOUR, JOSHUA C.	03012022	PER DIEM	214.00	214.00	02/25/2022
Total HONOUR, JOSHUA C.:					214.00	214.00	
MECHAM, DARREL							
113881	32306	MECHAM, DARREL	03012022	PER DIEM	214.00	214.00	02/25/2022
113881	32306	MECHAM, DARREL	02242022	CLOTHING REIMBURSEMENT	960.00	960.00	02/25/2022
Total MECHAM, DARREL:					1,174.00	1,174.00	
UTAH STATE DIV OF FINANCE							
113882	27720	UTAH STATE DIV OF FINANCE	M2102-2022	LOAN-M2102 EMS FACILITY	118,000.00	118,000.00	02/25/2022
Total UTAH STATE DIV OF FINANCE:					118,000.00	118,000.00	
Grand Totals:					223,927.46	223,927.46	

Date: March 1st 2022

County Auditor: _____

Council Chairperson: _____

Council: _____

Council: _____

Check No. _____

Report Criteria:

Report type: Summary

```
Check.Check number = {SQL} (tblCheck.CheckNumber in (SELECT c.CheckNumber
FROM      dbo.tblCheck c INNER JOIN
          dbo.tblCheckDetail cd ON c.ID = cd.tblCheckID
GROUP BY c.CheckNumber
HAVING   (SUM(cd.Amount) >= 10000)))
Check.Type = {<-> "Adjustment"
```

Payee	Check Number	Amount
GRAND COUNTY RECREATION SPECIAL SER. DIS	113834	137,000.00
HOGAN & ASSOCIATES CONSTRUCTION	113836	101,138.11
JONES & DEMILLE ENGINEERING INC	113840	33,768.34
MOAB AREA COMMUNITY LAND TRUST	113847	91,200.00
NICHOLAS AND COMPANY	113856	10,847.46
ROCKY MOUNTAIN POWER	113863	14,382.17
HOODOO MOAB	113876	15,929.60
GARLAND/DBS, INC.	113879	102,039.96
UTAH STATE DIV OF FINANCE	113882	118,000.00
Grand Totals:		<u>624,305.64</u>

Report Criteria:

Paid transmittals included

Transmittal Number	Name	Check Number	Pay Per Date	Pay Code	Description	GL Account	Amount
1							
1	DESERT RIVERS CREDIT	33701	02/20/2022	70-02	EMPLOYEE W/H Grand County Credit	10-2242000-000	300.00
Total 1:							300.00
3							
3	OFFICE OF RECOVERY S	33704	02/20/2022	69-02	Child Support Pay Period: 2/20/2022	10-2246000-000	460.40
3	OFFICE OF RECOVERY S	33704	02/20/2022	69-02	Child Support Pay Period: 2/20/2022	21-2246000-000	139.96
Total 3:							600.36
4							
4	GRAND COUNTY TREAS	33702	02/20/2022	66-00	EMPLOYEE W/H Grand County Treasur	10-2240000-000	523.85
4	GRAND COUNTY TREAS	33702	02/20/2022	66-00	EMPLOYEE W/H Grand County Treasur	21-2240000-000	70.00
4	GRAND COUNTY TREAS	33702	02/20/2022	66-00	EMPLOYEE W/H Grand County Treasur	45-2240000-000	56.00
Total 4:							649.85
10							
10	NATIONAL BENEFIT SER	33703	02/20/2022	71-03	GWSSA - HSA EE	11-3441-000-000	400.00
10	NATIONAL BENEFIT SER	33703	02/20/2022	71-03	GWSSA - HSA ER	11-3441-000-000	300.00
10	NATIONAL BENEFIT SER	33703	02/20/2022	71-01	GWSSA - FSA EE	11-3441-000-000	329.98
10	NATIONAL BENEFIT SER	33703	02/20/2022	71-01	EMPLOYEE W/H FSA (Cafe) Plan Pay	10-2256000-000	1,310.87
10	NATIONAL BENEFIT SER	33703	02/20/2022	71-01	EMPLOYEE W/H FSA (Cafe) Plan Pay	21-2256000-000	466.68
10	NATIONAL BENEFIT SER	33703	02/20/2022	71-01	EMPLOYEE W/H FSA (Cafe) Plan Pay	23-2256000-000	8.33
10	NATIONAL BENEFIT SER	33703	02/20/2022	71-01	EMPLOYEE W/H FSA (Cafe) Plan Pay	46-2256000-000	40.00
10	NATIONAL BENEFIT SER	33703	02/20/2022	71-01	EMPLOYEE W/H FSA (Cafe) Plan Pay	70-2256000-000	118.75
10	NATIONAL BENEFIT SER	33703	02/20/2022	71-01	EMPLOYEE W/H FSA (Cafe) Plan Pay	10-2256000-000	237.50
10	NATIONAL BENEFIT SER	33703	02/20/2022	71-02	EMPLOYEE W/H Dependent Child Care	10-2256000-000	381.94
10	NATIONAL BENEFIT SER	33703	02/20/2022	71-03	EMPLOYEE W/H HSA Plan Pay Period:	10-2257000-000	4,145.37
10	NATIONAL BENEFIT SER	33703	02/20/2022	71-03	EMPLOYEE W/H HSA Plan Pay Period:	17-2257000-000	60.00
10	NATIONAL BENEFIT SER	33703	02/20/2022	71-03	EMPLOYEE W/H HSA Plan Pay Period:	21-2257000-000	475.00
10	NATIONAL BENEFIT SER	33703	02/20/2022	71-03	EMPLOYEE W/H HSA Plan Pay Period:	23-2257000-000	306.08
10	NATIONAL BENEFIT SER	33703	02/20/2022	71-03	EMPLOYEE W/H HSA Plan Pay Period:	46-2257000-000	50.00
10	NATIONAL BENEFIT SER	33703	02/20/2022	71-03	EMPLOYEE W/H HSA Plan Pay Period:	47-2257000-000	30.00
10	NATIONAL BENEFIT SER	33703	02/20/2022	71-03	EMPLOYEE W/H HSA Plan Pay Period:	70-2257000-000	202.72
10	NATIONAL BENEFIT SER	33703	02/20/2022	71-03	EMPLOYEE W/H HSA Plan Pay Period:	72-2257000-000	509.16
10	NATIONAL BENEFIT SER	33703	02/20/2022	71-03	EMPLOYEE W/H HSA Plan Pay Period:	76-2257000-000	245.83
10	NATIONAL BENEFIT SER	33703	02/20/2022	71-03	EMPLOYEE W/H HSA Plan Pay Period:	10-2257000-000	5,508.75
10	NATIONAL BENEFIT SER	33703	02/20/2022	71-03	EMPLOYEE W/H HSA Plan Pay Period:	17-2257000-000	60.00
10	NATIONAL BENEFIT SER	33703	02/20/2022	71-03	EMPLOYEE W/H HSA Plan Pay Period:	21-2257000-000	800.00
10	NATIONAL BENEFIT SER	33703	02/20/2022	71-03	EMPLOYEE W/H HSA Plan Pay Period:	23-2257000-000	200.00
10	NATIONAL BENEFIT SER	33703	02/20/2022	71-03	EMPLOYEE W/H HSA Plan Pay Period:	45-2257000-000	50.00
10	NATIONAL BENEFIT SER	33703	02/20/2022	71-03	EMPLOYEE W/H HSA Plan Pay Period:	46-2257000-000	100.00
10	NATIONAL BENEFIT SER	33703	02/20/2022	71-03	EMPLOYEE W/H HSA Plan Pay Period:	47-2257000-000	100.00
10	NATIONAL BENEFIT SER	33703	02/20/2022	71-03	EMPLOYEE W/H HSA Plan Pay Period:	70-2257000-000	300.00
10	NATIONAL BENEFIT SER	33703	02/20/2022	71-03	EMPLOYEE W/H HSA Plan Pay Period:	72-2257000-000	500.00
10	NATIONAL BENEFIT SER	33703	02/20/2022	71-03	EMPLOYEE W/H HSA Plan Pay Period:	76-2257000-000	150.00
10	NATIONAL BENEFIT SER	22822105	02/20/2022	71-03	HSA PLAN ADMIN - JANUARY 2022	10-4562-130-000	7.50
10	NATIONAL BENEFIT SER	22822105	02/20/2022	71-03	HSA PLAN ADMIN - JANUARY 2022	10-4146-130-000	5.00
10	NATIONAL BENEFIT SER	22822105	02/20/2022	71-03	HSA PLAN ADMIN - JANUARY 2022	10-4145-130-000	5.00
10	NATIONAL BENEFIT SER	22822105	02/20/2022	71-03	HSA PLAN ADMIN - JANUARY 2022	10-4242-130-000	5.00
10	NATIONAL BENEFIT SER	22822105	02/20/2022	71-03	HSA PLAN ADMIN - JANUARY 2022	76-4275-130-000	5.00
10	NATIONAL BENEFIT SER	22822105	02/20/2022	71-03	HSA PLAN ADMIN - JANUARY 2022	45-4110-130-000	2.50

Transmittal Number	Name	Check Number	Pay Per Date	Pay Code	Description	GL Account	Amount
10	NATIONAL BENEFIT SER	22822105	02/20/2022	71-03	HSA PLAN ADMIN - JANUARY 2022	10-4142-130-000	12.50
10	NATIONAL BENEFIT SER	22822105	02/20/2022	71-03	HSA PLAN ADMIN - JANUARY 2022	10-4112-130-000	2.50
10	NATIONAL BENEFIT SER	22822105	02/20/2022	71-03	HSA PLAN ADMIN - JANUARY 2022	10-4160-130-000	7.50
10	NATIONAL BENEFIT SER	22822105	02/20/2022	71-03	HSA PLAN ADMIN - JANUARY 2022	46-4110-130-000	5.00
10	NATIONAL BENEFIT SER	22822105	02/20/2022	71-03	HSA PLAN ADMIN - JANUARY 2022	10-4114-130-000	5.00
10	NATIONAL BENEFIT SER	22822105	02/20/2022	71-03	HSA PLAN ADMIN - JANUARY 2022	10-4212-130-000	35.00
10	NATIONAL BENEFIT SER	22822105	02/20/2022	71-03	HSA PLAN ADMIN - JANUARY 2022	10-4122-130-000	7.50
10	NATIONAL BENEFIT SER	22822105	02/20/2022	71-03	HSA PLAN ADMIN - JANUARY 2022	72-4272-130-000	15.00
10	NATIONAL BENEFIT SER	22822105	02/20/2022	71-03	HSA PLAN ADMIN - JANUARY 2022	23-4236-130-000	7.50
10	NATIONAL BENEFIT SER	22822105	02/20/2022	71-03	HSA PLAN ADMIN - JANUARY 2022	10-4180-130-000	7.50
10	NATIONAL BENEFIT SER	22822105	02/20/2022	71-03	HSA PLAN ADMIN - JANUARY 2022	10-4113-130-000	2.50
10	NATIONAL BENEFIT SER	22822105	02/20/2022	71-03	HSA PLAN ADMIN - JANUARY 2022	10-4144-130-000	5.00
10	NATIONAL BENEFIT SER	22822105	02/20/2022	71-03	HSA PLAN ADMIN - JANUARY 2022	21-4520-130-000	20.00
10	NATIONAL BENEFIT SER	22822105	02/20/2022	71-03	HSA PLAN ADMIN - JANUARY 2022	70-4270-130-000	7.50
10	NATIONAL BENEFIT SER	22822105	02/20/2022	71-03	HSA PLAN ADMIN - JANUARY 2022	10-4311-130-000	12.50
10	NATIONAL BENEFIT SER	22822105	02/20/2022	71-03	HSA PLAN ADMIN - JANUARY 2022	10-4211-130-000	37.50
10	NATIONAL BENEFIT SER	22822105	02/20/2022	71-03	HSA PLAN ADMIN - JANUARY	10-4511-130-000	12.50
10	NATIONAL BENEFIT SER	22822105	02/20/2022	71-03	HSA PLAN ADMIN - JANUARY	10-4147-130-000	2.50
10	NATIONAL BENEFIT SER	22822105	02/20/2022	71-03	HSA PLAN ADMIN - JANUARY	47-4520-130-000	5.00
10	NATIONAL BENEFIT SER	22822105	02/20/2022	71-03	HSA PLAN ADMIN - JANUARY	10-4143-130-000	2.50
10	NATIONAL BENEFIT SER	22822105	02/20/2022	71-03	HSA PLAN ADMIN - JANUARY	10-4252-130-000	5.00
10	NATIONAL BENEFIT SER	22822105	02/20/2022	71-03	HSA PLAN ADMIN - JANUARY	11-3441-000-000	7.50
10	NATIONAL BENEFIT SER	22822105	02/20/2022	71-01	FSA PLAN ADMIN - JANUARY	10-4562-130-000	6.30
10	NATIONAL BENEFIT SER	22822105	02/20/2022	71-01	FSA PLAN ADMIN - JANUARY	10-4146-130-000	3.15
10	NATIONAL BENEFIT SER	22822105	02/20/2022	71-01	FSA PLAN ADMIN - JANUARY	10-4145-130-000	12.60
10	NATIONAL BENEFIT SER	22822105	02/20/2022	71-01	FSA PLAN ADMIN - JANUARY	10-4242-130-000	6.30
10	NATIONAL BENEFIT SER	22822105	02/20/2022	71-01	FSA PLAN ADMIN - JANUARY	10-4160-130-000	6.30
10	NATIONAL BENEFIT SER	22822105	02/20/2022	71-01	FSA PLAN ADMIN - JANUARY	46-4110-130-000	6.30
10	NATIONAL BENEFIT SER	22822105	02/20/2022	71-01	FSA PLAN ADMIN - JANUARY	10-4212-130-000	25.20
10	NATIONAL BENEFIT SER	22822105	02/20/2022	71-01	FSA PLAN ADMIN - JANUARY	10-4122-130-000	6.30
10	NATIONAL BENEFIT SER	22822105	02/20/2022	71-01	FSA PLAN ADMIN - JANUARY	72-4272-130-000	3.15
10	NATIONAL BENEFIT SER	22822105	02/20/2022	71-01	FSA PLAN ADMIN - JANUARY	23-4236-130-000	3.15
10	NATIONAL BENEFIT SER	22822105	02/20/2022	71-01	FSA PLAN ADMIN - JANUARY	10-4113-130-000	3.15
10	NATIONAL BENEFIT SER	22822105	02/20/2022	71-01	FSA PLAN ADMIN - JANUARY	10-4180-130-000	3.15
10	NATIONAL BENEFIT SER	22822105	02/20/2022	71-01	FSA PLAN ADMIN - JANUARY	21-4520-130-000	18.90
10	NATIONAL BENEFIT SER	22822105	02/20/2022	71-01	FSA PLAN ADMIN - JANUARY	70-4270-130-000	3.15
10	NATIONAL BENEFIT SER	22822105	02/20/2022	71-01	FSA PLAN ADMIN - JANUARY	10-4311-130-000	3.15
10	NATIONAL BENEFIT SER	22822105	02/20/2022	71-01	FSA PLAN ADMIN - JANUARY	10-4211-130-000	12.60
10	NATIONAL BENEFIT SER	22822105	02/20/2022	71-01	FSA PLAN ADMIN - JANUARY	10-4511-130-000	3.15
10	NATIONAL BENEFIT SER	22822105	02/20/2022	71-01	FSA PLAN ADMIN - JANUARY	10-4147-130-000	3.15
10	NATIONAL BENEFIT SER	22822105	02/20/2022	71-01	FSA PLAN ADMIN - JANUARY	10-4143-130-000	3.15
10	NATIONAL BENEFIT SER	22822105	02/20/2022	71-01	FSA PLAN ADMIN - JANUARY	10-4252-130-000	6.30
10	NATIONAL BENEFIT SER	22822105	02/20/2022	71-01	FSA PLAN ADMIN - GWSSA - JANUARY	11-3441-000-000	9.45
10	NATIONAL BENEFIT SER	22822108	02/20/2022	71-01	FSA PLAN ADMIN - ANNUAL MAINTEN	10-4562-130-000	8.51
10	NATIONAL BENEFIT SER	22822108	02/20/2022	71-01	FSA PLAN ADMIN - ANNUAL MAINTEN	10-4146-130-000	4.26
10	NATIONAL BENEFIT SER	22822108	02/20/2022	71-01	FSA PLAN ADMIN - ANNUAL MAINTEN	10-4145-130-000	17.02
10	NATIONAL BENEFIT SER	22822108	02/20/2022	71-01	FSA PLAN ADMIN - ANNUAL MAINTEN	10-4242-130-000	8.51
10	NATIONAL BENEFIT SER	22822108	02/20/2022	71-01	FSA PLAN ADMIN - ANNUAL MAINTEN	10-4160-130-000	8.51
10	NATIONAL BENEFIT SER	22822108	02/20/2022	71-01	FSA PLAN ADMIN - ANNUAL MAINTEN	46-4110-130-000	8.51
10	NATIONAL BENEFIT SER	22822108	02/20/2022	71-01	FSA PLAN ADMIN - ANNUAL MAINTEN	10-4212-130-000	34.01
10	NATIONAL BENEFIT SER	22822108	02/20/2022	71-01	FSA PLAN ADMIN - ANNUAL MAINTEN	10-4122-130-000	8.51
10	NATIONAL BENEFIT SER	22822108	02/20/2022	71-01	FSA PLAN ADMIN - ANNUAL MAINTEN	72-4272-130-000	4.26
10	NATIONAL BENEFIT SER	22822108	02/20/2022	71-01	FSA PLAN ADMIN - ANNUAL MAINTEN	23-4236-130-000	4.26
10	NATIONAL BENEFIT SER	22822108	02/20/2022	71-01	FSA PLAN ADMIN - ANNUAL MAINTEN	10-4113-130-000	4.27
10	NATIONAL BENEFIT SER	22822108	02/20/2022	71-01	FSA PLAN ADMIN - ANNUAL MAINTEN	10-4180-130-000	4.26
10	NATIONAL BENEFIT SER	22822108	02/20/2022	71-01	FSA PLAN ADMIN - ANNUAL MAINTEN	21-4520-130-000	25.51
10	NATIONAL BENEFIT SER	22822108	02/20/2022	71-01	FSA PLAN ADMIN - ANNUAL MAINTEN	70-4270-130-000	4.26

Transmittal Number	Name	Check Number	Pay Per Date	Pay Code	Description	GL Account	Amount
10	NATIONAL BENEFIT SER	22822108	02/20/2022	71-01	FSA PLAN ADMIN - ANNUAL MAINTEN	10-4311-130-000	4.26
10	NATIONAL BENEFIT SER	22822108	02/20/2022	71-01	FSA PLAN ADMIN - ANNUAL MAINTEN	10-4211-130-000	17.02
10	NATIONAL BENEFIT SER	22822108	02/20/2022	71-01	FSA PLAN ADMIN - ANNUAL MAINTEN	10-4511-130-000	4.26
10	NATIONAL BENEFIT SER	22822108	02/20/2022	71-01	FSA PLAN ADMIN - ANNUAL MAINTEN	10-4147-130-000	4.26
10	NATIONAL BENEFIT SER	22822108	02/20/2022	71-01	FSA PLAN ADMIN - ANNUAL MAINTEN	10-4143-130-000	4.26
10	NATIONAL BENEFIT SER	22822108	02/20/2022	71-01	FSA PLAN ADMIN - ANNUAL MAINTEN	10-4252-130-000	8.51
10	NATIONAL BENEFIT SER	22822108	02/20/2022	71-01	FSA PLAN ADMIN - ANNUAL MAINTEN	11-3441-000-000	12.77
Total 10:							17,990.01
25	LIBERTY MUTUAL INSUR	33706	02/20/2022	63-00	LIBERTY MUTUAL- EMP W/H	10-2234000-000	1,152.32
25	LIBERTY MUTUAL INSUR	33706	02/20/2022	63-00	LIBERTY MUTUAL- EMP W/H	21-2234000-000	374.40
25	LIBERTY MUTUAL INSUR	33706	02/20/2022	63-00	LIBERTY MUTUAL- EMP W/H	23-2234000-000	114.54
25	LIBERTY MUTUAL INSUR	33706	02/20/2022	63-00	LIBERTY MUTUAL- EMP W/H	72-2234000-000	355.66
Total 25:							1,996.92
28	UTAH RETIREMENT SYS	22822107	02/20/2022	40-01	Utah Retirement T1 401(K) Pay Period:	10-2261000-000	2,106.42
28	UTAH RETIREMENT SYS	22822107	02/20/2022	40-01	Utah Retirement T1 401(K) Pay Period:	21-2261000-000	447.08
28	UTAH RETIREMENT SYS	22822107	02/20/2022	40-01	Utah Retirement T1 401(K) Pay Period:	70-2261000-000	700.00
28	UTAH RETIREMENT SYS	22822107	02/20/2022	40-01	Utah Retirement T1 401(K) Pay Period:	72-2261000-000	445.96
28	UTAH RETIREMENT SYS	22822107	02/20/2022	40-01	Utah Retirement T1 401(K) Pay Period:	76-2261000-000	1,000.00
28	UTAH RETIREMENT SYS	22822107	02/20/2022	40-01	Utah Retirement T1 401(K) Pay Period:	10-2261000-000	1,528.46
28	UTAH RETIREMENT SYS	22822107	02/20/2022	40-01	Utah Retirement T1 401(K) Pay Period:	21-2261000-000	620.23
28	UTAH RETIREMENT SYS	22822107	02/20/2022	40-01	Utah Retirement T1 401(K) Pay Period:	23-2261000-000	52.79
28	UTAH RETIREMENT SYS	22822107	02/20/2022	40-01	Utah Retirement T1 401(K) Pay Period:	46-2261000-000	42.93
28	UTAH RETIREMENT SYS	22822107	02/20/2022	40-01	Utah Retirement T1 401(K) Pay Period:	70-2261000-000	156.83
28	UTAH RETIREMENT SYS	22822107	02/20/2022	40-01	Utah Retirement T1 401(K) Pay Period:	72-2261000-000	247.45
28	UTAH RETIREMENT SYS	22822107	02/20/2022	40-01	Utah Retirement T1 401(K) Pay Period:	75-2261000-000	40.99
28	UTAH RETIREMENT SYS	22822107	02/20/2022	40-01	Utah Retirement T1 401(K) Pay Period:	76-2261000-000	61.34
28	UTAH RETIREMENT SYS	22822107	02/20/2022	40-02	Utah Retirement T1 401(K) Pol Pay Peri	10-2261000-000	2,614.12
28	UTAH RETIREMENT SYS	22822107	02/20/2022	40-06	Utah Retirement T2 DB HYB 401(K) Pa	10-2261000-000	1,294.60
28	UTAH RETIREMENT SYS	22822107	02/20/2022	40-06	Utah Retirement T2 DB HYB 401(K) Pa	21-2261000-000	100.00
28	UTAH RETIREMENT SYS	22822107	02/20/2022	40-06	Utah Retirement T2 DB HYB 401(K) Pa	72-2261000-000	100.00
28	UTAH RETIREMENT SYS	22822107	02/20/2022	40-06	Utah Retirement T2 DB HYB 401(K) Pa	10-2261000-000	541.49
28	UTAH RETIREMENT SYS	22822107	02/20/2022	40-06	Utah Retirement T2 DB HYB 401(K) Pa	21-2261000-000	79.40
28	UTAH RETIREMENT SYS	22822107	02/20/2022	40-06	Utah Retirement T2 DB HYB 401(K) Pa	23-2261000-000	30.64
28	UTAH RETIREMENT SYS	22822107	02/20/2022	40-06	Utah Retirement T2 DB HYB 401(K) Pa	45-2261000-000	7.52
28	UTAH RETIREMENT SYS	22822107	02/20/2022	40-06	Utah Retirement T2 DB HYB 401(K) Pa	46-2261000-000	19.18
28	UTAH RETIREMENT SYS	22822107	02/20/2022	40-06	Utah Retirement T2 DB HYB 401(K) Pa	70-2261000-000	9.70
28	UTAH RETIREMENT SYS	22822107	02/20/2022	40-06	Utah Retirement T2 DB HYB 401(K) Pa	72-2261000-000	39.54
28	UTAH RETIREMENT SYS	22822107	02/20/2022	40-06	Utah Retirement T2 DB HYB 401(K) Pa	75-2261000-000	15.50
28	UTAH RETIREMENT SYS	22822107	02/20/2022	40-06	Utah Retirement T2 DB HYB 401(K) Pa	76-2261000-000	23.81
28	UTAH RETIREMENT SYS	22822107	02/20/2022	40-07	Utah Retirement T2 DB PS HYB 401(K)	10-2261000-000	414.62
28	UTAH RETIREMENT SYS	22822107	02/20/2022	40-08	Utah Retirement T2 DC 401(K) Pay Peri	10-2261000-000	403.15
28	UTAH RETIREMENT SYS	22822107	02/20/2022	40-08	Utah Retirement T2 DC 401(K) Pay Peri	10-2261000-000	2,211.90
28	UTAH RETIREMENT SYS	22822107	02/20/2022	40-08	Utah Retirement T2 DC 401(K) Pay Peri	23-2261000-000	685.72
28	UTAH RETIREMENT SYS	22822107	02/20/2022	40-09	Utah Retirement T2 DC PS 401(K) Pay	10-2261000-000	300.00
28	UTAH RETIREMENT SYS	22822107	02/20/2022	40-09	Utah Retirement T2 DC PS 401(K) Pay	10-2261000-000	699.20
28	UTAH RETIREMENT SYS	22822107	02/20/2022	41-01	Utah Retirement 457 Pay Period: 2/20/2	10-2263000-000	1,267.92
28	UTAH RETIREMENT SYS	22822107	02/20/2022	41-01	Utah Retirement 457 Pay Period: 2/20/2	21-2263000-000	52.51
28	UTAH RETIREMENT SYS	22822107	02/20/2022	42-00	Utah Retirement ROTH IRA Pay Period:	10-2258000-000	1,415.00
28	UTAH RETIREMENT SYS	22822107	02/20/2022	42-00	Utah Retirement ROTH IRA Pay Period:	72-2258000-000	100.00
28	UTAH RETIREMENT SYS	22822107	02/20/2022	43-00	Utah Retirement TRADITIONAL IRA Pa	10-2258000-000	150.00
28	UTAH RETIREMENT SYS	22822107	02/20/2022	51-00	Utah Retirement Retirement-repay of loa	10-2259000-000	784.95

Transmittal Number	Name	Check Number	Pay Per Date	Pay Code	Description	GL Account	Amount
28	UTAH RETIREMENT SYS	22822107	02/20/2022	51-00	Utah Retirement Retirement-repay of loa	21-2259000-000	247.25
28	UTAH RETIREMENT SYS	22822107	02/20/2022	51-00	Utah Retirement Retirement-repay of loa	45-2259000-000	54.65
28	UTAH RETIREMENT SYS	22822107	02/20/2022	51-00	Utah Retirement Retirement-repay of loa	72-2259000-000	85.42
28	UTAH RETIREMENT SYS	22822107	02/20/2022	51-00	Utah Retirement Retirement-repay of loa	75-2259000-000	56.38
28	UTAH RETIREMENT SYS	22822107	02/20/2022	55-01	Utah Retirement T2 DB Hybrid Pay Peri	10-2260000-000	14,034.73
28	UTAH RETIREMENT SYS	22822107	02/20/2022	55-01	Utah Retirement T2 DB Hybrid Pay Peri	21-2260000-000	2,058.04
28	UTAH RETIREMENT SYS	22822107	02/20/2022	55-01	Utah Retirement T2 DB Hybrid Pay Peri	23-2260000-000	793.94
28	UTAH RETIREMENT SYS	22822107	02/20/2022	55-01	Utah Retirement T2 DB Hybrid Pay Peri	45-2260000-000	194.80
28	UTAH RETIREMENT SYS	22822107	02/20/2022	55-01	Utah Retirement T2 DB Hybrid Pay Peri	46-2260000-000	497.12
28	UTAH RETIREMENT SYS	22822107	02/20/2022	55-01	Utah Retirement T2 DB Hybrid Pay Peri	70-2260000-000	251.54
28	UTAH RETIREMENT SYS	22822107	02/20/2022	55-01	Utah Retirement T2 DB Hybrid Pay Peri	72-2260000-000	1,024.94
28	UTAH RETIREMENT SYS	22822107	02/20/2022	55-01	Utah Retirement T2 DB Hybrid Pay Peri	75-2260000-000	401.75
28	UTAH RETIREMENT SYS	22822107	02/20/2022	55-01	Utah Retirement T2 DB Hybrid Pay Peri	76-2260000-000	617.09
28	UTAH RETIREMENT SYS	22822107	02/20/2022	55-02	Utah Retirement T2 DB PS Hybrid Pay	10-2260000-000	942.94
28	UTAH RETIREMENT SYS	22822107	02/20/2022	55-02	Utah Retirement T2 DB PS Hybrid Pay	10-2260000-000	11,211.73
28	UTAH RETIREMENT SYS	22822107	02/20/2022	55-03	Utah Retirement T2 DC Pay Period: 2/	10-2260000-000	1,329.80
28	UTAH RETIREMENT SYS	22822107	02/20/2022	55-03	Utah Retirement T2 DC Pay Period: 2/	23-2260000-000	458.75
28	UTAH RETIREMENT SYS	22822107	02/20/2022	55-03	Utah Retirement T2 DC Pay Period: 2/	47-2260000-000	149.97
28	UTAH RETIREMENT SYS	22822107	02/20/2022	55-04	Utah Retirement T2 DC PS Pay Period:	10-2260000-000	648.76
28	UTAH RETIREMENT SYS	22822107	02/20/2022	90-01	Utah Retirement T1 Non-Contributory R	10-2260000-000	12,930.33
28	UTAH RETIREMENT SYS	22822107	02/20/2022	90-01	Utah Retirement T1 Non-Contributory R	21-2260000-000	5,756.68
28	UTAH RETIREMENT SYS	22822107	02/20/2022	90-01	Utah Retirement T1 Non-Contributory R	23-2260000-000	490.00
28	UTAH RETIREMENT SYS	22822107	02/20/2022	90-01	Utah Retirement T1 Non-Contributory R	46-2260000-000	398.42
28	UTAH RETIREMENT SYS	22822107	02/20/2022	90-01	Utah Retirement T1 Non-Contributory R	70-2260000-000	1,455.61
28	UTAH RETIREMENT SYS	22822107	02/20/2022	90-01	Utah Retirement T1 Non-Contributory R	72-2260000-000	2,296.82
28	UTAH RETIREMENT SYS	22822107	02/20/2022	90-01	Utah Retirement T1 Non-Contributory R	75-2260000-000	380.48
28	UTAH RETIREMENT SYS	22822107	02/20/2022	90-01	Utah Retirement T1 Non-Contributory R	76-2260000-000	569.32
28	UTAH RETIREMENT SYS	22822107	02/20/2022	90-03	Utah Retirement T1 Police Non-Contrib	10-2260000-000	11,363.65
28	UTAH RETIREMENT SYS	22822107	02/20/2022	90-03	Utah Retirement T1 Police Non-Contrib	17-2260000-000	625.79
Total 28:							92,137.65

29

29	IRS - FICA/FWT	22822103	02/20/2022	74-00	FICA/FWT Social Security Pay Period:	10-2221000-000	18,297.12
29	IRS - FICA/FWT	22822103	02/20/2022	74-00	FICA/FWT Social Security Pay Period:	17-2221000-000	125.62
29	IRS - FICA/FWT	22822103	02/20/2022	74-00	FICA/FWT Social Security Pay Period:	20-2221000-000	65.10
29	IRS - FICA/FWT	22822103	02/20/2022	74-00	FICA/FWT Social Security Pay Period:	21-2221000-000	2,467.94
29	IRS - FICA/FWT	22822103	02/20/2022	74-00	FICA/FWT Social Security Pay Period:	23-2221000-000	1,062.42
29	IRS - FICA/FWT	22822103	02/20/2022	74-00	FICA/FWT Social Security Pay Period:	25-2221000-000	190.30
29	IRS - FICA/FWT	22822103	02/20/2022	74-00	FICA/FWT Social Security Pay Period:	30-2221000-000	13.46
29	IRS - FICA/FWT	22822103	02/20/2022	74-00	FICA/FWT Social Security Pay Period:	45-2221000-000	96.54
29	IRS - FICA/FWT	22822103	02/20/2022	74-00	FICA/FWT Social Security Pay Period:	46-2221000-000	394.28
29	IRS - FICA/FWT	22822103	02/20/2022	74-00	FICA/FWT Social Security Pay Period:	47-2221000-000	292.20
29	IRS - FICA/FWT	22822103	02/20/2022	74-00	FICA/FWT Social Security Pay Period:	70-2221000-000	619.62
29	IRS - FICA/FWT	22822103	02/20/2022	74-00	FICA/FWT Social Security Pay Period:	72-2221000-000	1,539.37
29	IRS - FICA/FWT	22822103	02/20/2022	74-00	FICA/FWT Social Security Pay Period:	75-2221000-000	282.72
29	IRS - FICA/FWT	22822103	02/20/2022	74-00	FICA/FWT Social Security Pay Period:	76-2221000-000	416.74
29	IRS - FICA/FWT	22822103	02/20/2022	74-00	FICA/FWT Social Security Pay Period:	10-2221000-000	18,089.61
29	IRS - FICA/FWT	22822103	02/20/2022	74-00	FICA/FWT Social Security Pay Period:	17-2221000-000	125.62
29	IRS - FICA/FWT	22822103	02/20/2022	74-00	FICA/FWT Social Security Pay Period:	20-2221000-000	65.10
29	IRS - FICA/FWT	22822103	02/20/2022	74-00	FICA/FWT Social Security Pay Period:	21-2221000-000	2,675.45
29	IRS - FICA/FWT	22822103	02/20/2022	74-00	FICA/FWT Social Security Pay Period:	23-2221000-000	1,062.42
29	IRS - FICA/FWT	22822103	02/20/2022	74-00	FICA/FWT Social Security Pay Period:	25-2221000-000	190.30
29	IRS - FICA/FWT	22822103	02/20/2022	74-00	FICA/FWT Social Security Pay Period:	30-2221000-000	13.46
29	IRS - FICA/FWT	22822103	02/20/2022	74-00	FICA/FWT Social Security Pay Period:	45-2221000-000	96.54
29	IRS - FICA/FWT	22822103	02/20/2022	74-00	FICA/FWT Social Security Pay Period:	46-2221000-000	394.28
29	IRS - FICA/FWT	22822103	02/20/2022	74-00	FICA/FWT Social Security Pay Period:	47-2221000-000	292.20

Transmittal Number	Name	Check Number	Pay Per Date	Pay Code	Description	GL Account	Amount
29	IRS - FICA/FWT	22822103	02/20/2022	74-00	FICA/FWT Social Security Pay Period:	70-2221000-000	619.62
29	IRS - FICA/FWT	22822103	02/20/2022	74-00	FICA/FWT Social Security Pay Period:	72-2221000-000	1,539.37
29	IRS - FICA/FWT	22822103	02/20/2022	74-00	FICA/FWT Social Security Pay Period:	75-2221000-000	282.72
29	IRS - FICA/FWT	22822103	02/20/2022	74-00	FICA/FWT Social Security Pay Period:	76-2221000-000	416.74
29	IRS - FICA/FWT	22822103	02/20/2022	75-00	FICA/FWT Medicare Pay Period: 2/20/2	10-2224000-000	4,230.62
29	IRS - FICA/FWT	22822103	02/20/2022	75-00	FICA/FWT Medicare Pay Period: 2/20/2	17-2224000-000	29.38
29	IRS - FICA/FWT	22822103	02/20/2022	75-00	FICA/FWT Medicare Pay Period: 2/20/2	20-2224000-000	15.23
29	IRS - FICA/FWT	22822103	02/20/2022	75-00	FICA/FWT Medicare Pay Period: 2/20/2	21-2224000-000	625.71
29	IRS - FICA/FWT	22822103	02/20/2022	75-00	FICA/FWT Medicare Pay Period: 2/20/2	23-2224000-000	248.47
29	IRS - FICA/FWT	22822103	02/20/2022	75-00	FICA/FWT Medicare Pay Period: 2/20/2	25-2224000-000	44.51
29	IRS - FICA/FWT	22822103	02/20/2022	75-00	FICA/FWT Medicare Pay Period: 2/20/2	30-2224000-000	3.15
29	IRS - FICA/FWT	22822103	02/20/2022	75-00	FICA/FWT Medicare Pay Period: 2/20/2	45-2224000-000	22.58
29	IRS - FICA/FWT	22822103	02/20/2022	75-00	FICA/FWT Medicare Pay Period: 2/20/2	46-2224000-000	92.20
29	IRS - FICA/FWT	22822103	02/20/2022	75-00	FICA/FWT Medicare Pay Period: 2/20/2	47-2224000-000	68.33
29	IRS - FICA/FWT	22822103	02/20/2022	75-00	FICA/FWT Medicare Pay Period: 2/20/2	70-2224000-000	144.91
29	IRS - FICA/FWT	22822103	02/20/2022	75-00	FICA/FWT Medicare Pay Period: 2/20/2	72-2224000-000	360.02
29	IRS - FICA/FWT	22822103	02/20/2022	75-00	FICA/FWT Medicare Pay Period: 2/20/2	75-2224000-000	66.12
29	IRS - FICA/FWT	22822103	02/20/2022	75-00	FICA/FWT Medicare Pay Period: 2/20/2	76-2224000-000	97.46
29	IRS - FICA/FWT	22822103	02/20/2022	75-00	FICA/FWT Medicare Pay Period: 2/20/2	10-2224000-000	4,230.62
29	IRS - FICA/FWT	22822103	02/20/2022	75-00	FICA/FWT Medicare Pay Period: 2/20/2	17-2224000-000	29.38
29	IRS - FICA/FWT	22822103	02/20/2022	75-00	FICA/FWT Medicare Pay Period: 2/20/2	20-2224000-000	15.23
29	IRS - FICA/FWT	22822103	02/20/2022	75-00	FICA/FWT Medicare Pay Period: 2/20/2	21-2224000-000	625.71
29	IRS - FICA/FWT	22822103	02/20/2022	75-00	FICA/FWT Medicare Pay Period: 2/20/2	23-2224000-000	248.47
29	IRS - FICA/FWT	22822103	02/20/2022	75-00	FICA/FWT Medicare Pay Period: 2/20/2	25-2224000-000	44.51
29	IRS - FICA/FWT	22822103	02/20/2022	75-00	FICA/FWT Medicare Pay Period: 2/20/2	30-2224000-000	3.15
29	IRS - FICA/FWT	22822103	02/20/2022	75-00	FICA/FWT Medicare Pay Period: 2/20/2	45-2224000-000	22.58
29	IRS - FICA/FWT	22822103	02/20/2022	75-00	FICA/FWT Medicare Pay Period: 2/20/2	46-2224000-000	92.20
29	IRS - FICA/FWT	22822103	02/20/2022	75-00	FICA/FWT Medicare Pay Period: 2/20/2	47-2224000-000	68.33
29	IRS - FICA/FWT	22822103	02/20/2022	75-00	FICA/FWT Medicare Pay Period: 2/20/2	70-2224000-000	144.91
29	IRS - FICA/FWT	22822103	02/20/2022	75-00	FICA/FWT Medicare Pay Period: 2/20/2	72-2224000-000	360.02
29	IRS - FICA/FWT	22822103	02/20/2022	75-00	FICA/FWT Medicare Pay Period: 2/20/2	75-2224000-000	66.12
29	IRS - FICA/FWT	22822103	02/20/2022	75-00	FICA/FWT Medicare Pay Period: 2/20/2	76-2224000-000	97.46
29	IRS - FICA/FWT	22822103	02/20/2022	76-00	FICA/FWT Federal Withholding Pay Peri	10-2222000-000	31,211.44
29	IRS - FICA/FWT	22822103	02/20/2022	76-00	FICA/FWT Federal Withholding Pay Peri	17-2222000-000	272.92
29	IRS - FICA/FWT	22822103	02/20/2022	76-00	FICA/FWT Federal Withholding Pay Peri	20-2222000-000	98.02
29	IRS - FICA/FWT	22822103	02/20/2022	76-00	FICA/FWT Federal Withholding Pay Peri	21-2222000-000	4,566.14
29	IRS - FICA/FWT	22822103	02/20/2022	76-00	FICA/FWT Federal Withholding Pay Peri	23-2222000-000	2,213.81
29	IRS - FICA/FWT	22822103	02/20/2022	76-00	FICA/FWT Federal Withholding Pay Peri	45-2222000-000	139.02
29	IRS - FICA/FWT	22822103	02/20/2022	76-00	FICA/FWT Federal Withholding Pay Peri	46-2222000-000	563.87
29	IRS - FICA/FWT	22822103	02/20/2022	76-00	FICA/FWT Federal Withholding Pay Peri	47-2222000-000	21.07
29	IRS - FICA/FWT	22822103	02/20/2022	76-00	FICA/FWT Federal Withholding Pay Peri	70-2222000-000	674.64
29	IRS - FICA/FWT	22822103	02/20/2022	76-00	FICA/FWT Federal Withholding Pay Peri	72-2222000-000	1,988.32
29	IRS - FICA/FWT	22822103	02/20/2022	76-00	FICA/FWT Federal Withholding Pay Peri	75-2222000-000	556.05
29	IRS - FICA/FWT	22822103	02/20/2022	76-00	FICA/FWT Federal Withholding Pay Peri	76-2222000-000	379.20
Total 29:							106,508.74
40							
40	CIGNA HEALTHCARE - C	22822102	02/20/2022	62-07	FEBRUARY - CLAIMS	11-4225-400-000	160,574.78
40	CIGNA HEALTHCARE - C	22822102	02/20/2022	62-05	FEBRUARY - PREMIUM	11-4225-400-000	72,979.27
Total 40:							233,554.05
43							
43	LINCOLN NATIONAL LIFE	22822104	02/20/2022	61-05	LINCOLN - SINGLE(EMP) - FEBRUARY	11-4220-410-000	363.08
43	LINCOLN NATIONAL LIFE	22822104	02/20/2022	61-05	LINCOLN - SINGLE(EMR) - FEBRUARY	11-4220-410-000	485.08
43	LINCOLN NATIONAL LIFE	22822104	02/20/2022	61-06	LINCOLN - OUTSIDE AGENCIES - FEB	11-4220-410-000	220.88

Transmittal Number	Name	Check Number	Pay Per Date	Pay Code	Description	GL Account	Amount
43	LINCOLN NATIONAL LIFE	22822104	02/20/2022	96-00	LINCOLN - LTD PO - FEBRUARY	10-2262000-000	462.48
43	LINCOLN NATIONAL LIFE	22822104	02/20/2022	97-00	LINCOLN - LTD - FEBRUARY	10-2262000-000	1,726.11
43	LINCOLN NATIONAL LIFE	22822104	02/20/2022	97-00	LINCOLN - LTD - FEBRUARY	21-2262000-000	260.24
43	LINCOLN NATIONAL LIFE	22822104	02/20/2022	97-00	LINCOLN - LTD - FEBRUARY	23-2262000-000	16.88
43	LINCOLN NATIONAL LIFE	22822104	02/20/2022	97-00	LINCOLN - LTD - FEBRUARY	45-2262000-000	16.46
43	LINCOLN NATIONAL LIFE	22822104	02/20/2022	97-00	LINCOLN - LTD - FEBRUARY	46-2262000-000	36.04
43	LINCOLN NATIONAL LIFE	22822104	02/20/2022	97-00	LINCOLN - LTD - FEBRUARY	47-2262000-000	31.96
43	LINCOLN NATIONAL LIFE	22822104	02/20/2022	97-00	LINCOLN - LTD - FEBRUARY	70-2262000-000	52.18
43	LINCOLN NATIONAL LIFE	22822104	02/20/2022	97-00	LINCOLN - LTD - FEBRUARY	72-2262000-000	94.62
43	LINCOLN NATIONAL LIFE	22822104	02/20/2022	61-06	LINCOLN - EMP ADJUSTMENTS - FEB	11-4220-410-000	276.33
43	LINCOLN NATIONAL LIFE	22822104	02/20/2022	61-06	LINCOLN - 2 PARTY & FAMILY(EMR) -	11-4220-410-000	1,306.30
43	LINCOLN NATIONAL LIFE	22822104	02/20/2022	61-06	LINCOLN - 2 PARTY & FAMILY(EMP) - F	11-4220-410-000	1,859.76
Total 43:							7,208.40
47	SOUTH TOWNE GYM	33707	02/20/2022	67-00	BRAXTON HINES 2022 MEMBERSHIP	10-2255000-000	295.00
Total 47:							295.00
99	UTAH LOCAL GOVERNMENT	33708	02/20/2022	99-00	WORKERS COMP - FEBRUARY 2022	10-2254000-000	7,367.09
99	UTAH LOCAL GOVERNMENT	33708	02/20/2022	99-00	WORKERS COMP - FEBRUARY 2022	17-2254000-000	43.55
99	UTAH LOCAL GOVERNMENT	33708	02/20/2022	99-00	WORKERS COMP - FEBRUARY 2022	21-2254000-000	1,277.58
99	UTAH LOCAL GOVERNMENT	33708	02/20/2022	99-00	WORKERS COMP - FEBRUARY 2022	23-2254000-000	567.76
99	UTAH LOCAL GOVERNMENT	33708	02/20/2022	99-00	WORKERS COMP - FEBRUARY 2022	30-2254000-000	4.04
99	UTAH LOCAL GOVERNMENT	33708	02/20/2022	99-00	WORKERS COMP - FEBRUARY 2022	47-2254000-000	270.41
99	UTAH LOCAL GOVERNMENT	33708	02/20/2022	99-00	WORKERS COMP - FEBRUARY 2022	45-2254000-000	79.22
99	UTAH LOCAL GOVERNMENT	33708	02/20/2022	99-00	WORKERS COMP - FEBRUARY 2022	46-2254000-000	204.10
99	UTAH LOCAL GOVERNMENT	33708	02/20/2022	99-00	WORKERS COMP - FEBRUARY 2022	70-2254000-000	330.84
99	UTAH LOCAL GOVERNMENT	33708	02/20/2022	99-00	WORKERS COMP - FEBRUARY 2022	72-2254000-000	793.88
99	UTAH LOCAL GOVERNMENT	33708	02/20/2022	99-00	WORKERS COMP - FEBRUARY 2022	75-2254000-000	340.54
99	UTAH LOCAL GOVERNMENT	33708	02/20/2022	99-00	WORKERS COMP - FEBRUARY 2022	20-2254000-000	11.45
99	UTAH LOCAL GOVERNMENT	33708	02/20/2022	99-00	WORKERS COMP - FEBRUARY 2022	23-2254000-000	87.17
Total 99:							11,377.63
6107	ALLSTATE BENEFITS	22822101	02/20/2022	61-07	ALLSTATE - FEBRUARY EMP W/H	10-2247000-000	2,491.50
6107	ALLSTATE BENEFITS	22822101	02/20/2022	61-07	ALLSTATE - FEBRUARY EMP W/H	17-2247000-000	15.02
6107	ALLSTATE BENEFITS	22822101	02/20/2022	61-07	ALLSTATE - FEBRUARY EMP W/H	21-2247000-000	712.74
6107	ALLSTATE BENEFITS	22822101	02/20/2022	61-07	ALLSTATE - FEBRUARY EMP W/H	23-2247000-000	61.30
6107	ALLSTATE BENEFITS	22822101	02/20/2022	61-07	ALLSTATE - FEBRUARY EMP W/H	45-2247000-000	26.94
6107	ALLSTATE BENEFITS	22822101	02/20/2022	61-07	ALLSTATE - FEBRUARY EMP W/H	46-2247000-000	19.56
6107	ALLSTATE BENEFITS	22822101	02/20/2022	61-07	ALLSTATE - FEBRUARY EMP W/H	47-2247000-000	27.92
6107	ALLSTATE BENEFITS	22822101	02/20/2022	61-07	ALLSTATE - FEBRUARY EMP W/H	70-2247000-000	44.48
6107	ALLSTATE BENEFITS	22822101	02/20/2022	61-07	ALLSTATE - FEBRUARY EMP W/H	72-2247000-000	109.12
6107	ALLSTATE BENEFITS	22822101	02/20/2022	61-07	ALLSTATE - FEBRUARY EMP W/H - GR	11-3441-000-000	10.76
Total 6107:							3,519.34
6108	THE STANDARD INSURANCE	22822106	02/20/2022	61-08	STANDARD - EMPLOYEE W/H - FEBRU	10-2248000-000	656.98
6108	THE STANDARD INSURANCE	22822106	02/20/2022	61-08	STANDARD - EMPLOYEE W/H - FEBRU	21-2248000-000	100.92
6108	THE STANDARD INSURANCE	22822106	02/20/2022	61-08	STANDARD - EMPLOYEE W/H - FEBRU	45-2248000-000	10.00
6108	THE STANDARD INSURANCE	22822106	02/20/2022	61-08	STANDARD - EMPLOYEE W/H - FEBRU	46-2248000-000	32.54
6108	THE STANDARD INSURANCE	22822106	02/20/2022	61-08	STANDARD - EMPLOYEE W/H - FEBRU	72-2248000-000	10.00

Transmittal Number	Name	Check Number	Pay Per Date	Pay Code	Description	GL Account	Amount
Total 6108:							810.44
6501							
6501	BLOMQUIST HALE CONS	33705	02/20/2022	65-01	EMPLOYER - INV# FEB22089 - FEBRU	10-2266000-000	356.78
6501	BLOMQUIST HALE CONS	33705	02/20/2022	65-01	EMPLOYER - INV# FEB22089 - FEBRU	17-2266000-000	2.30
6501	BLOMQUIST HALE CONS	33705	02/20/2022	65-01	EMPLOYER - INV# FEB22089 - FEBRU	21-2266000-000	61.12
6501	BLOMQUIST HALE CONS	33705	02/20/2022	65-01	EMPLOYER - INV# FEB22089 - FEBRU	23-2266000-000	22.92
6501	BLOMQUIST HALE CONS	33705	02/20/2022	65-01	EMPLOYER - INV# FEB22089 - FEBRU	46-2266000-000	7.64
6501	BLOMQUIST HALE CONS	33705	02/20/2022	65-01	EMPLOYER - INV# FEB22089 - FEBRU	47-2266000-000	7.64
6501	BLOMQUIST HALE CONS	33705	02/20/2022	65-01	EMPLOYER - INV# FEB22089 - FEBRU	70-2266000-000	11.46
6501	BLOMQUIST HALE CONS	33705	02/20/2022	65-01	EMPLOYER - INV# FEB22089 - FEBRU	72-2266000-000	26.74
6501	BLOMQUIST HALE CONS	33705	02/20/2022	65-01	EMPLOYER - INV# FEB22089 - FEBRU	76-2266000-000	3.82
Total 6501:							500.42
Grand Totals:							477,448.81

Report Criteria:
Paid transmittals included

DATE:	<u>3/1/22</u>
CHECK NUMBERS:	<u>33701-33708</u>
TRANSMITTAL NUMBERS:	<u>22822101-22822108</u>
AMOUNTS OF NOTE:	<u>Cigna # 233,554.05</u>
COUNTY AUDITOR:	_____
COMMISSION MEMBER:	_____
COMMISSION MEMBER:	_____

#33,107.14
#444,341.67

Report Criteria:

Department.Department = {AND} {<->} "THOMPSON FIRE DISTRICT"

Total AIRPORT:	6	.00	.00	11,000.42
Total ASSESSOR:	4	.00	.00	6,930.26
Total ATTORNEY:	7	.00	.00	15,599.42
Total BUILDING INSPECTOR:	3	.00	.00	5,957.26
Total CEMETARY DISTRICT:	3	.00	.00	4,568.52
Total CHILD JUST CTR:	1	.00	.00	1,085.53
Total CLERK/AUDITOR:	5	.00	.00	9,483.14
Total COUNTY ADMINISTRATOR:	2	.00	.00	6,686.74
Total COUNTY COUNCIL:	7	.00	.00	8,025.87
Total COURTHOUSE:	6	.00	.00	8,755.20
Total FAMILY SUPPORT CENTE:	5	.00	.00	4,863.08
Total INFORMATION TECHNOLOGY:	2	.00	.00	4,384.56
Total JAIL:	18	.00	.00	31,679.43
Total JUSTICE COURT:	5	.00	.00	7,581.16
Total LIBRARY:	16	.00	.00	18,602.82
Total MOAB MOSQUITO DISTRI:	2	.00	.00	3,373.01
Total MOAB PROMOTION:	7	.00	.00	12,531.27
Total PERSONNEL SERVICES:	2	.00	.00	3,537.24
Total PLANNING & ZONING:	9	.00	.00	12,502.97
Total RECORDER:	3	.00	.00	5,719.77
Total ROADS - CLASS B:	18	.00	.00	30,662.86
Total SANDFLATS RECREATION:	6	.00	.00	7,319.87
Total SEARCH & RESCUE:	16	.00	.00	4,665.16
Total SENIOR CITIZENS:	7	.00	.00	8,935.56
Total SHERIFF:	19	.00	.00	43,782.78
Total SPANISH TRAIL ARENA:	6	.00	.00	9,971.59
Total SURVEYOR:	1	.00	.00	770.08
Total TREASURER:	2	.00	.00	4,529.19
Total WEED CONTROL:	4	.00	.00	6,052.97

Grand Totals:

192	.00	.00	299,557.73
-----	-----	-----	------------

Report Criteria:

Department.Department = {AND} {<>} "THOMPSON FIRE DISTRICT"

DATE:	<u>3/1/22</u>
CHECK NUMBERS:	<u>33700</u>
TRANSMITTAL NUMBERS:	<u>22522101-22522292</u>
AMOUNTS OF NOTE:	_____
COUNTY AUDITOR:	_____
COMMISSION MEMBER:	_____
COMMISSION MEMBER:	_____



GRAND COUNTY COMMISSION
Gabriel Woytek (Chair) · Jacques Hadler (Vice Chair)
Evan Clapper · Trish Hedin · Mary McGann
Sarah Stock · Kevin Walker

March 1, 2022

To Whom it May Concern,

The Grand County Commission supports the Thompson Special Service District (TSSD) negotiating a preliminary agreement with the Department of Energy and the Moab Uranium Mill Tailings Remedial Action (collectively UMTRA) and raising state funding to hire an engineering firm to conduct a feasibility study regarding the UMTRA/TSSD Green River Pipeline concept.

TSSD's utilization of Water Right No. 92-677 and related conveyance infrastructure would be a happy ending to a quarter century long toxic tailings removal project. And it may allow for development of the Thompson Springs area which has the potential to be a great benefit to Grand County, the State of Utah, and the United States in general for the following reasons:

1. In regard to the County, Thompson Springs is a rural hub and would be a great location to allow for county growth, including affordable housing to support the service industry workers in Moab.
2. In regard to the State, it is the first service area stop coming from Colorado off of I-70 and Union Pacific Railway corridors and a perfect welcoming point into Utah.
3. In regard to the country, it is ideally located very close to the northern entrances of Arches and Canyonlands National Parks and is nestled in between the Green and Colorado Rivers making it an ideal extension to Moab's basecamp location for national and international visitors to enjoy some of the most amazing scenic landscapes our nation has to offer.

Grand County would like to see the feasibility study analyze the impact of the current Millenium Drought and a Colorado River Compact Call (absent a renegotiation of the Colorado River guidelines) on TSSD's ability to rely on the Water Right No. 92-677 to strategically develop the Thompson Springs/Crescent Junction area. However, even if the study ultimately determines that the Water Right cannot survive a Compact Call, there is great value in designating it as an alternate point of diversion for TSSD's surface water rights, which are at risk. In fact, Grand County supports TSSD working with UMTRA to immediately file a permanent change application for TSSD's water rights to add Water Right No. 92-677 as an alternate point of diversion. And the County recommends TSSD engage property owners along the Green River pipeline route to secure permanent easements sooner than later.

Respectfully,

Gabriel Woytek, Chair
 Grand County Commission

AGENDA SUMMARY
GRAND COUNTY COMMISSION MEETING
MARCH 1, 2022
 Agenda Item: F

TITLE:	Approving Volunteer Appointment(s) to District and County Boards and Commissions: Canyonlands Health Care Special Service District Board
FISCAL IMPACT:	None
PRESENTER(S):	Jacques Hadler, Commission Liaison for the Board

Prepared By:

qh

FOR OFFICE USE ONLY:

Attorney Review:

N/A

RECOMMENDATION:

I move to approve the appointment of Joette Langianese to serve on the Canyonlands Health Care Special Service District Board with the term expiring 12/31/2025.

BACKGROUND:

The Canyonlands Health Care Special Service District Board met in an open meeting on 10 February, 2022 and reviewed one application submitted for four open vacancies as of 12/31/2021, and interviewed the applicants. The Board voted unanimously to recommend the appointment of Joette Langianese, with term expiring 12/31/2025.

Upon appointment, the Commission's Office will e-mail the appointees a letter congratulating them and inviting them to a training / orientation to be scheduled for 2022.

ATTACHMENT(S):

1. Application received from Joette Langianese
2. Board recommendation letter

CANYONLANDS HEALTH CARE SPECIAL SERVICE DISTRICT
450 West Williams Way
Moab UT 84532

February 10, 2022

Grand County Commission
125 E. Center Street
Moab, UT 84532

Re: Canyonlands Health Care Special Service District Board Appointment Recommendation

Dear Grand County Commission:

The Canyonlands Health Care Special Service District (CHCSSD) received 1 application(s) for 2 open vacancies. The Canyonlands Health Care Special Service District met on February 10th and interviewed candidate Joette Langianese.

On February 10th the Canyonlands Health Care Special Service District board met in an open meeting and voted unanimously to recommend to the Commission to reappoint Joette Langianese for a term ending December 31, 2025.

Please let me know if you have any questions.

Thank you for your consideration.

Sincerely;

Tim McGInty
CHCSSD Vice Chair



Board and Commission Application and Certification Form

Instructions: Complete and sign this form and return it to Grand County Council Office, 125 E. Center St., Moab, UT 84532; fax: 435-259-2574; or council@grandcountyutah.net

Board or Commission Position Applied For: CHCSSD

Name: Joette Langianese

Mailing Address: [REDACTED]

City: Moab State: UT ZIP Code: 84532

Day Phone: [REDACTED] Email Address: [REDACTED]

In what year did you establish your current residency in Grand County? 1997
(residency is required for all Boards; some District boards require residency within the District, which may not include Moab City limits; **two** years' residency prior to assuming board membership is required for Planning Commission)

If not Grand County, which county do you reside in? (applicable for Historical Preservation Commission and Housing Authority of Southeastern Utah) _____

Occupation or professional training: MS Gerontology/BS Community Health Ed

List your work experience that is relevant to your application for a position on the Board or Commission for which you are applying (if needed, attach a separate page):

Served on the CHCSSD Board for the past 4 years with 3 years serving as Chair.

Served on the CHCSSD Board from 2002-2008 as the County Council Representative.

List your non-work experience that is relevant to your application for a position on the Board or Commission for which you are applying:

Grand County Resolution 3007 (December 2013) contains the following Board Member requirements:

- Must be a Grand County resident (unless otherwise noted);
- Terms shall be for four years, unless a shorter period is required by law, or unless a mid-term vacancy is being filled;
- All terms shall end December 31st with the new member taking office the first meeting in January of the following year;
- Board Members shall have the appropriate expertise when required by law;
- Submit applications to the Council's Office in accordance with the requirements contained in the notice;
- Agree to abide by the County's Conflict of Interest Ordinance.

Additionally, the State Code has the following requirements for *Special Service Districts in Grand County*:

- No appointed member of the Board may be a full or part-time employee of the District while serving on the Board;
- No person employed by a Special Service District as a full-time or part-time employee may serve on the Governing Board of the District;
- A Board Member may not be compensated separately as a Board Member and as an employee for providing the same service;
- Each Trustee/Board Member appointed by the County legislative body shall be an elector (registered voter) of the District.

I have read, and I certify, that all the information on this form is true and correct and I meet the requirements listed above. Furthermore, if appointed, I agree to faithfully attend the meetings and adhere to the State laws, County ordinances, and adopted Bylaws that govern the Board or Commission on which I am appointed to serve. Additionally, I have read the County's Conflict of Interest Ordinance (No. 462, November 2007) and do not have any inherent conflicts in serving on the Board or Commission to which I have applied. I agree to abide by this Ordinance.

Signature: Joette Langianese Date: 2/8/22

CANYONLANDS HEALTH CARE SPECIAL SERVICE DISTRICT
450 West Williams Way
Moab UT 84532

February 10, 2022

Grand County Commission
125 E. Center Street
Moab, UT 84532

Re: Canyonlands Health Care Special Service District Board Appointment Recommendation

Dear Grand County Commission:

The Canyonlands Health Care Special Service District (CHCSSD) received 1 application(s) for 2 open vacancies. The Canyonlands Health Care Special Service District met on February 10th and interviewed candidate Joette Langianese.

On February 10th the Canyonlands Health Care Special Service District board met in an open meeting and voted unanimously to recommend to the Commission to reappoint Joette Langianese for a term ending December 31, 2025.

Please let me know if you have any questions.

Thank you for your consideration.

Sincerely;

Tim McGInty
CHCSSD Vice Chair

AGENDA SUMMARY
GRAND COUNTY COMMISSION MEETING
MARCH 1, 2022
Agenda Item: G

TITLE:	Legislative Update (2022 General Session)
FISCAL IMPACT:	Varied per bill - consult Fiscal Notes for each bill at utah.gov
PRESENTER(S):	Christina Sloan, County Attorney

Prepared By:

Christina Sloan,
Grand County
Attorney

FOR OFFICE USE ONLY:

Attorney Review:

Complete

SUGGESTED MOTION:

I move to support House Bills 462 and 474 and oppose HB 303, and authorize the Chair to sign any necessary letters of opposition or support to Utah legislators deemed necessary by the County Legislative Committee or County Attorney.

NEW BILLS:

HB 303 (Rep. Val Peterson)
Local Land Use Amendments
<https://le.utah.gov/~2022/bills/static/HB0303.html>
Recommendation: Oppose

Like HB 474 (see below), this bill is big and proposes numerous changes to LUDMA. However, SB303S02 amended the definition of “land use decision” to remove administrative enforcement actions by local government, which appears to be related to the Summit County Hideout Annexation fight and actions by bad actors.

It also inserts a new provision related to inclusionary zoning, currently applicable only to cities (but could be expanded to include counties at any time). The amended language (lines 827-842) does still allow inclusionary zoning by agreement/incentive but would prohibit the City from requiring a % of new lots be required in new subdivisions (which must be proportional to impact and backed by nexxus study, etc. anyway), a huge blow to workforce housing for all of us - and bad policy as it'll encourage us to downzone land to preserve the inclusionary zoning option.

It also conflicts with HB 462 (see below).

HB 462 (Rep. Waldrip)
Utah Housing Affordability Amendments
<https://le.utah.gov/~2022/bills/static/HB0462.html>
Recommendation: Support

This bill is a beast: among other things, it requires certain political subdivisions to adopt an implementation plan as part of the moderate

income housing element of the political subdivision's general plan; modifies the list of strategies that a political subdivision may select for implementation as part of the moderate income housing element of the political subdivision's general plan; requires certain political subdivisions to amend the political subdivision's general plan by a specified date if the general plan does not include certain provisions related to moderate income housing; addresses state funding priorities and requirements; requires a political subdivision to require the owner of a dwelling to obtain a license or permit for renting internal accessory dwelling units; allows a political subdivision to require certain physical changes for internal accessory dwelling units constructed before a specified date; limits a political subdivision's ability to impose certain requirements on internal accessory dwelling units constructed before a specified date; prohibits a political subdivision from imposing impact fees for the construction of certain internal accessory dwelling units; requires the division to develop a methodology for determining whether a political subdivision is complying with certain moderate income housing requirements, establishes the Rural Housing Fund, to be used by the division to provide loans for certain moderate income housing projects in rural areas; allows state entities, in addition to political subdivisions, to grant real property for certain developments that include moderate income housing; and repeals provisions that prohibit a political subdivision from adopting certain ordinances related to short-term rentals.

Much of this bill only applies to cities, or urban cities and counties. "Moderate income housing" is defined to mean housing occupied or reserved for occupancy by households with a gross household income equal to or less than 80% of the median gross income for households of the same size in the county in which the housing is located.

ADU revisions are technical and not objectionable from a first glance. The bill gives rural Utah a voice on the Housing Loan Fund Board and establishes a Rural Housing Fund to help fund moderate income housing (via loan) - and appropriates money to these funds and more.

HB 474 (Rep Waldrip)

LUDMA Amendments

<https://le.utah.gov/~2022/bills/static/HB0474.html>

Recommendation: Support

This consensus bill of the Land Use Task Force modifies provisions related to when a person may challenge an annexation in district court; modifies notice requirements related to an amendment to public improvements in a subdivision or development; removes a prohibition on imposing a land use regulation under certain circumstances; modifies evidence requirements related to a noncomplying structure or a nonconforming use; authorizes a municipality or a county to determine if combining lots constitutes a subdivision amendment; modifies the requirements for preparation of a subdivided plat by a surveyor; and

modifies provisions related to determining when a land use decision is illegal; and creates a process to establish an agreed boundary between landowners when a boundary is disputed or uncertain.

Importantly, this bill removes some horrible language that got inserted into LUDMA last year that prohibits application of any changes to land use regulations to a subdivision within 10 years of approval, which was an administrative nightmare. Yay!

It also makes the following clarification to the non-conforming use section: Unless the county establishes, by ordinance, a uniform presumption of legal existence for nonconforming uses, the property owner shall have the burden of establishing the legal existence of a noncomplying structure or nonconforming use through substantial evidence, which may not be limited to municipal or county records. "Substantial evidence" is a lower legal standard, so I recommend we establish a higher standard by ordinance and integrate it into Section 1 of the Land Use Code.

EXISTING PENDING BILLS GRAND OPPOSES:

HB 146 (Rep. Lisonbee)

Food Truck Licensing Amendments

<https://le.utah.gov/~2022/bills/static/HB0146.html>

Action: GCC Opposes

Status: ALERT - We've received reliable information that Senator Bramble intends to introduce a last-minute amendment on the floor to prohibit cities and counties from regulating ATV businesses. Grand County has initiated a letter writing campaign in opposition to all Senators.

This bill expands the definition of a food truck to include ice cream trucks, requires a political subdivision to honor a food truck business license from another jurisdiction, and prohibits local land use/zoning regulation of food trucks including their size.

HB 182 (Rep. Wilson)

Local Health Department Amendments

<https://le.utah.gov/~2022/bills/static/HB0182.html>

Action: GCC Opposes

Status: Passed the House; in Committee in the Senate

This bill excludes state facilities and the capitol hill complex from the authority and jurisdiction of a local health department and prohibits a chief executive officer of a municipality from exercising emergency powers in response to a pandemic, an epidemic, or a public health emergency (this is targeted at SLC Mayor's action in 2021 to enact a mask mandate on her own due to loophole).

Overly broad and affects health regulations above and beyond a lot more than COVID regulations.

Update: 1st Sub narrows the reach to orders of constraint only, as expected.
2nd Sub requires a supermajority to approve

HB 324 (Rep. Ballard)

Criminal Justice Coordinating Councils

<https://le.utah.gov/~2022/bills/static/HB0324.html>

Recommendation: Oppose

Status: Still in House Rules Comm (so likely not advancing)

HB 324 and SB 179 are competing bills, one of which encourages (HB 324) county-level criminal justice advisory councils and one of which would mandate them (SB 179).

While the concepts are good, these bills present big challenges for Rural Utah.

The County Attorney is very supportive of taking a hard look at the way we prosecute crime and doing what we can to ensure that we are using best practices, evidence based approaches, and continually improving the work that we do to improve public safety and to improve situations for individuals and families. Grand County (and GCAO in particular) is already supporting a diversionary Drug Court and baby Mental Health Court, a Children's Justice Center, and a Family Support Center. Partner agencies, including advocacy organizations, involved in law enforcement and prosecution meet often to review the work we are doing, look at the data we have, and make improvements where we can. For the size of most rural counties, the type of formal structured council proposed by either of these bills would likely create additional bureaucracy that would hinder the work already being done by the County instead of helping it.

In addition, there isn't funding for the proposed councils, and it will be a challenge to find an adequate number of unbiased volunteers to support these boards in small counties. If we had one board for the entire 7th Judicial District, we might be able to get the resources together and enough volunteers, but it would be close to impossible to create standards or common goals for the various communities across this incredibly large area of the state.

SB 45 (Sen. Anderegg)

Dept of Health and Human Services Amendments

<https://le.utah.gov/~2022/bills/static/SB0045.html>

Action: GCC Opposes

Status: Passed the Senate; amended in the House to vest existing local laws that are more stringent than state law but prevents their future amendment. So a partial win, but we hope to fix this language in the future.

This bill implements the reorganization of the Department of Health and Human Services; specifies the duties and responsibilities of the newly combined agency; and harmonizes conflicting provisions of the Utah Health Code and the Utah Human Services Code.

Floor amendments prohibit the local health department from adopting regulations that are more stringent than state and federal law. SEUHD has notified the County Attorney that the following areas of regulation would be affected:

Body art
Housing
Food service
Lodging
Public pools
Onsite wastewater (septic)
Body art

Many counties are concerned and opposed.

SB 51 (Sen. Harper)

Transportation Amendments

<https://le.utah.gov/~2022/bills/static/SB0051.html>

Recommendation: Oppose

Status: Advancing slowly

After initially introducing a very different SB 51 (to change emissions regulations for vintage vehicles), Sen. Harper later introduced a revision of SB51 to the Transportation Committee to allow flexibility in existing coal project funding for use for hydrocarbon development.

Grand initially suspected this bill was aimed at funding the Bookcliffs Highway, but after listening to committee hearings and SCIC meetings and after our lobbyist met with sponsors, we have confirmed this is not aimed at BCH. And, interestingly, the SCIC is for the first time fracturing on the issue of funding the BCH!

SB 66 (Sen. Weiler)

Electric Assisted Bicycle Use Amendments

<https://le.utah.gov/~2022/bills/static/SB0066.html#41-22-2>

Action: GCC Opposes

Status: Grand County has worked actively to educate the Sponsors on the unintended impacts of this bill on our destination biking economy.

Specifically, we have worked with the House Sponsor to revise the bill to focus only on mandated access for disabled persons on adaptive ebikes or to circle the bill for now so that we may work on it this year. As of 2/24, this bill is circled and likely will not progress this year.

This bill adds a definition to the Traffic Code for a Class I *mountain* bike (all e-bikes were defined previously as bicycles, not mountain bikes). And then it prohibits local governments from regulating Class I mountain bikes on dirt trails if the operator has a trail accessibility card, which may be obtained from DNR for persons with a "cycling disability," as determined by essentially a medical professional.

In doing so, this bill:

1) Conflicts with Federal Regulation and Federal Grant Obligations. Most of Grand County's single-track mountain bike trails on BLM land, and I'm guessing nearly all single-track mtn bike trails in the state on BLM land, were built with federal Recreational Trails Program (RTP) grant funding, in whole or in part. RTP trails cannot be used for motorized use, so this language, as written, conflicts with federal regulations and existing grant conditions to which Grand County is obligated. Obviously, federal law would preempt SB 66, but that only matters for federal law enforcement, and we know federal LEOs are in scarce supply in rural Utah. So, this bill creates a quagmire of confusion.

2) Safety/SAR Impacts. Class I bikes require pedal assist, so there is some level of required activity to get out on mountain bike trails, but our trails are the real deal and quickly take you into remote canyon country where services are nil and rescues are complicated. This bill will empower disabled folks who should not be in Moab's backcountry to get into Moab's backcountry, only to get themselves in trouble. The Grand County Search and Rescue is already the busiest in the state - and we already do not have sufficient financial resources to handle our call volume and needs. If this bill is passed, then appropriations for SAR should go along with it as it is simple reality that this bill will increase injuries and deaths by bike in Grand County.

SB 179 (Sen Weiler)

Criminal Justice Amendments

<https://le.utah.gov/~2022/bills/static/SB0179.html>

Recommendation: Oppose

Update: Still in House Rules Committee but working on 3rd Sub

HB 324 and SB 179 are competing bills, one of which encourages (HB 324) county-level criminal justice advisory councils and one of which would mandate them (SB 179). See HB 324 above for more information.

EXISTING PENDING BILLS GRAND SUPPORTS OR IS NEUTRAL:

HB 57 (Rep. Stoddard)

Government Records Access Amendments

<https://le.utah.gov/~2022/bills/static/HB0057.html>

Recommendation: Neutral

This bill amends GRAMA to specify that an item that, if retained by a governmental entity, would be considered to be a record, does not lose its character as a record because it is located only on a personal electronic device of the governmental entity's official or employee; prohibits a governmental entity from searching a personal electronic device of an official or employee in responding to a record request; requires a governmental entity responding to a record request to request an official or employee to search a personal electronic device for an electronic record

located on the personal electronic device; and provides that the governmental entity may rely on the results of the official or employee's search.

Thus, this bill specifies that it is sufficient for an employee of a political subdivision to search their own phone in response to a GRAMA request, and their response may be relied on by the political subdivision. In talking with my County Attorney peers, this appears to track fairly closely with what a lot of counties already do. Some media groups are opposed.

Update: Substitute language is being worked out with counties in opposition to improve this bill.

HB 135 (Rep. Brammer)

Open and Public Meeting Comment Requirements

<https://le.utah.gov/~2022/bills/static/HB0135.html>

Recommendation: Neutral

This bill amends GRAMA to require a public body to allow a reasonable opportunity for the public to provide verbal comment at each public *meeting*. This is consistent with Grand County's practice; however, several counties are opposing it as they allow public comment at public hearings only (and on vagueness grounds). Apparently this is targeted at school board meetings.

Update: 1st Substitute provides an exception for work and planning sessions.

HB 140 (Rep. Birkeland)

Government Attorney Fees Amendment

<https://le.utah.gov/~2022/bills/static/HB0140.html>

Action: GCC Opposes

Status: Still in the House Rules Committee (so unlikely to advance)

This bill requires a court to award reasonable attorney fees to a private party who prevails in certain civil actions against a governmental entity and permits a court to award reasonable expert fees to a private party who prevails in certain civil actions against a governmental entity. The first substitute caps the fees awarded to \$100,000.

In doing so, this bill incentivizes litigation against state and local government, conflicts with other existing fee provisions in statute (such as the real property ombudsman fee allowance in the event a private party prevails in court after an appeal of an ombudsman decision), and will drive up insurance costs for the County.

HB 372 (Rep. Moss)

Short Term Property Rental Amendments

<https://le.utah.gov/~2022/bills/static/HB0372.html>

Recommendation: Support

Status: Still in Committee and not scheduled for a hearing yet

This bill allows a legislative body may enact and enforce an ordinance that prohibits an individual from listing or offering a short-term rental on a short-term rental website; and imposes a civil penalty in accordance with Subsection 10-3-703(2) for the act of listing or offering a short-term rental on a short-term website.

SB 49 (Sen. Winterton)

State Film Production Incentive Amendments

<https://le.utah.gov/~2022/bills/static/SB0049.html>

Action: GCC Supports

Status: Passed the Senate; now in Committee in the House

This bill exempts certain rural film productions from limits on the total amount of refundable motion picture tax credit incentives the Governor's Office of Economic Opportunity may issue each fiscal year.

Update: The County is actively working to help this bill pass.

PASSED BILLS:

HB 323 (Rep. Last)

Transient Room Tax Amendments

<https://le.utah.gov/~2022/bills/static/HB0323.html>

Status: PASSED HOUSE AND SENATE

This bill authorizes certain counties to use a certain amount of transient room tax revenue and TRT reserves for “visitor management” and “destination development” if the expenditure is prioritized and recommended by a county's tourism tax advisory board; limits the amount of TRT funds a County can save in a TRT reserve fund; requires the legislative body to consider the recommendations of the county's tourism tax advisory board in a public meeting; and restates a TRT reporting requirement contained elsewhere in statute.

Most of these changes are positive and increase transparency regarding TRT spending. And the bill was revised to more clearly allow the new spending on “visitor management” and “destination development” to be in addition to the Section 2 spending allowances.

BILLS THAT FAILED TO ADVANCE:

HB 72 (Rep. Wheatley)

Noise Pollution Amendments

<https://le.utah.gov/~2022/bills/static/HB0072.html>

Action: GCC Supports

Status: Failed to pass Committee

This bill requires vehicles subject to an emissions inspection to be inspected for compliance with noise suppression equipment requirements as a

condition of registration. Emissions tests are required in urban counties, so this would ensure ATVs traveling from urban counties have not modified their noise suppression equipment in violation of Utah law.

HB 147 (Rep. Lowry)

Death Penalty Modifications

<https://le.utah.gov/~2022/bills/static/HB0147.html>

Action: GCC Supports

Status: House LE and Criminal Justice Committee voted not to advance it 6-5 after a compelling committee hearing

This bill prohibits the state from seeking the death penalty for aggravated murder committed after May 4, 2022; prohibits the state from seeking the death penalty for aggravated murder committed before May 4, 2022, unless the state filed the notice of intent to seek the death penalty before that date; and adds a possible sentence for aggravated murder of 45 years to life.

In the County Attorney's position, the United States criminal justice system, while the best in the world, is a system based on the work of flawed humans who are underpaid, often undereducated, and overworked. Errors happen (at a rate of about 10% in national death penalty cases). In addition, the use of the death penalty by prosecutors during charging hampers a defendant's ability to enter a voluntary plea. It's also dramatically more expensive to Utah residents than a life sentence. And the law of revenge (Hammurabi's code) was best exercised at the time of its writing, in the 1700s BC.

HB 371 (Rep. Lyman)

Voting Revisions

<https://le.utah.gov/~2022/bills/static/HB0371.html>

Recommendation: Oppose

Status: House General Operations Committee voted not to advance it 7-3 after an interesting committee hearing

This bill is an attempt to make voting harder. It removes a ballot drop box as a location where an individual may deposit a ballot; modifies voter registration forms; removes voting by mail as the primary voting method in the state and replaces it with in-person voting; addresses the form, handling, depositing, and tabulation of ballots; establishes an absentee ballot process for certain voters who are unable to vote at a polling place during early voting or on election day; makes it unlawful to engage in voter registration harvesting; modifies the period of time for which certain election items must be preserved; requires an independent post-election audit and describes the requirements for that audit; requires a recount based on certain audit results; prohibits drive-through polling locations; imposes election security and transparency requirements; and modifies ballot printing and tracking requirements.

SB 89 (Sen. Iwamoto)

Water Amendments

<https://le.utah.gov/~2022/bills/static/SB0089.html>

Action: GCC Supports

This bill modifies provisions related to a water conservation plan, including provisions: requiring goals for water conservation to be set; addressing adopting, amending, submitting, or posting a water conservation plan; requiring rate structures to be submitted under certain circumstances; and addressing division powers, including rulemaking; and modifies provision related to culinary water pricing structure.

Update: Moving forward with a minor amendment. Still in the Senate.

SB 110 (Sen. McKell)

Water as Part of General Plan

<https://le.utah.gov/~2022/bills/static/SB0110.html>

Action: GCC Supports

This bill requires a water use and preservation element to be part of a municipal or county general plan; outlines how a water use and preservation element is integrated into a general plan and what steps to take in developing a water use and preservation element; provides for action related to the general plan by the legislative body of a municipality or county; and addresses assistance by the Division of Water Resources.

The Grand County PZ Director is reviewing our General Plan Update to ensure it is consistent with these amendments.

Update: Moving forward. Still in the Senate. The County Attorney has requested an update from our PZ Director regarding our own compliance.

SB 126 (Sen. Iwamoto)

Officer Intervention and Reporting Requirements

<https://le.utah.gov/~2022/bills/static/SB0126.html>

Action: GCC Supports

This bill creates minimum standards for police misconduct; sets standards for intervention and reporting requirements in law enforcement agencies; requires the Peace Officer Standards and Training Council to establish and review minimum standards for reporting police misconduct; and prohibits retaliatory action against a law enforcement agency employee who reports police misconduct.

Update: Moving forward. Still in the Senate.

ATTACHMENT(S):

1. White paper on HB 462

AGENDA SUMMARY
GRAND COUNTY COMMISSION MEETING
MARCH 1, 2022
 Agenda Item: H

TITLE:	Approving bid award for mobile stage and associated purchase agreement
FISCAL IMPACT:	\$161,590 total bid price (\$80,000 to come from the City of Moab)
PRESENTER(S):	Mallory Nassau, Commission Administrator

Prepared By:

Chris Baird
 Strategic Dev.
 Director

FOR OFFICE USE ONLY:

Attorney Review:

SUGGESTED MOTION:

I move to award the bid for a mobile stage to Stageline Mobile Stage Inc., for a price not to exceed \$161,590, and approve a contract for such contingent upon approval of the purchasing agent and County Attorney.

BACKGROUND:

Grand County and the City of Moab are interested in jointly funding and making available a mobile stage for the purposes of facilitating and incentivizing the performing arts in Grand County.

The City of Moab has agreed to fund approximately half of the mobile stage purchase (\$80,000), and Grand County has budgeted to cover the remainder.

One bid was received from Stageline Mobile Stage Inc. An evaluation committee consisting of Chris Baird, Mallory Nassau, and Quinn Hall has recommended approval of the Stageline bid, and certifies that the bid meets all qualifications contained in the invitation to bid and is within budget.

The anticipated delivery date is September/October if the bid is approved at the March 1 meeting. Staff from Grand County and the City of Moab will work with one another and various other interested entities to design and implement a policy for the scheduling and use of the stage prior to the delivery date.

A purchase agreement still needs to be drafted. The suggested motion would pre-approve an agreement contingent upon approval of the agreement by the Grand County purchasing agent and the Grand County Attorney. The point of the pre-approval is to expedite the order so that the stage may be used this fall.

ATTACHMENT(S):

1. Stageline cover letter, bid, and brochure

Grand County, UT
ITB - 24' x 20' Mobile Stage
DEADLINE: February 24th, 2022

SL100

HYDRAULIC MOBILE STAGE

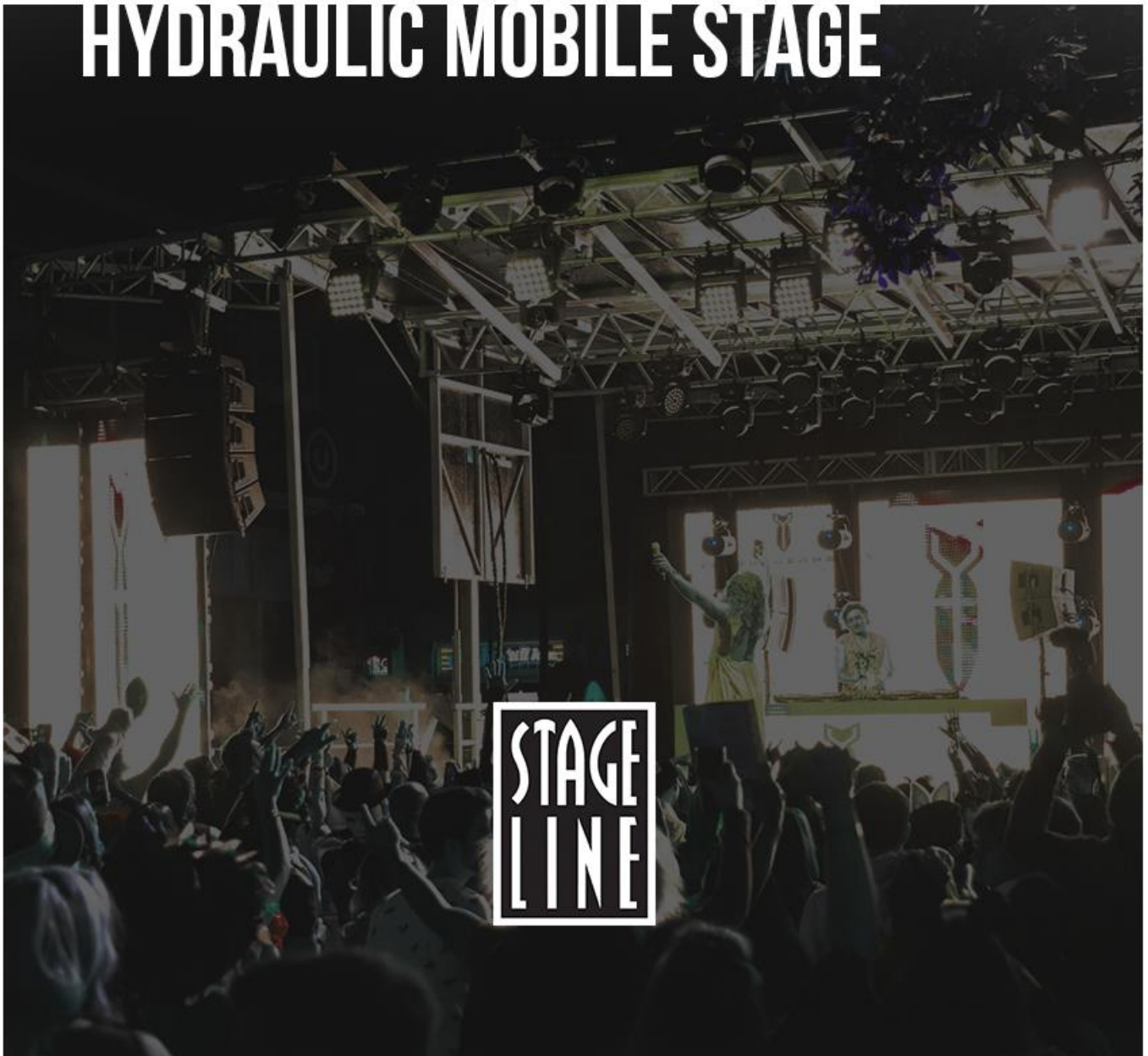

STAGE
LINE



TABLE OF CONTENTS

GRAND COUNTY, UT

24' x 20' MOBILE STAGE

STAGELINE SL100

- Resolution of the Board of Directors
- Bid forms
- Price list
- SL100 benefits
- Brochure – abridged version – full copy submitted separately
- Technical Factors
- Technical Drawings
- Photos
- Engineer Stamps
- Warranty

ANNEXED DOCUMENTS

- Safety Declaration
- Stageline Corporate Profile & References
- Proof of Insurance
- Worker's Compensation (CNESST)
- W8-BEN
- Training Program
- Inspection Program
- Eco-conscious Company



RESOLUTION OF THE BOARD OF DIRECTORS

STAGELINE MOBILE STAGE

BE IT RESOLVED:

That Tony Beresford is authorized to sign for and on behalf of the Corporation: all documents, including any amendments he considers to be necessary, within the proposal for Grand County, UT for a 24' x 20' mobile stage. The Corporation hereby ratifies the signature of its representative and approves all aforementioned amendments.

INSERTION IN THE BOOK:

IT IS RESOLVED to insert a signed copy of the present resolution in the book of the company, in accordance with the provisions of the Canada Business Corporations Act.

VALIDITY:

The written resolution above, being signed by the President and Chief Executive Officer (CEO) has the same value as if it had been passed at a meeting of the Directors, pursuant to the Canada Business Corporations Act.

Signed at L'Assomption on February 17, 2022

A handwritten signature in blue ink, appearing to read "PLR", is written above a horizontal line.

Pierre-Luc Rompré
Operations Director

FORM 1 Public Records Law

THIS FORM MUST BE COMPLETED AND RETURNED WITH YOUR PROPOSAL

Upon selection of the award, submittals become "public records" and shall be subject to public disclosure consistent with the Government Records Access and Management Act. Those who submit must invoke the exemptions to disclosure provided by law in the response to the solicitation, and must identify the data or other materials to be protected, and must state the reasons why such exclusion from public disclosure is necessary.

If you submit information exempt from public disclosure, you must identify with specificity which page(s)/paragraph(s) of your proposal package is (are) exempt from the Government Records Access and Management Act and identify the specific exemption section that applies to each. The protected information must be submitted to the County in a separate envelope marked accordingly. By submitting an offer in response to this solicitation, you specifically agree to defend and indemnify Grand County, County Commission, and its officers, employees and agents, and hold them harmless from any claim or liability and defend any action brought against them for their refusal to disclose copyrighted material, trade secrets or other proprietary information to any person making a request therefore.

Company Name: Stageline Mobile Stage inc.

Authorized representative (printed): Tony Beresford

Authorized representative (signature): 

Date: 18th February 2022

Part I - Bidding Specifications and Guidelines 24' x 20' Mobile Stage

ITEM	SPECIFICATIONS	YES	NO
1.0 STANDARD FEATURES			
<i>1.1 Manufacturing Norms & standards</i>	<p>Manufacturer shall state they are the owner of the Brand Name and trademark of the product and that the product is entirely fabricated and assembled at its manufacturing plant by its qualified personnel. Manufacturer must have a team of professional engineers specialized in the design and fabrication of that model.</p> <p>The manufacturer shall state that no more than 20% of the product is fabricated by subcontractors.</p> <p>Manufacturer shall have a quality control manual demonstrating each checkpoint inspected during the manufacturing process.</p> <p>Manufacturer shall provide proof they are properly accredited by competent authorities and that all welders working on the manufacturing of the product have their CSA W47.1 and CSA W 47.2 welding certifications or equivalent.</p>	x	
<i>1.2 Track record</i>	<p>Must be an established model and manufacturer shall have built a minimum of 20 units of the same model in its facilities.</p> <p>Manufacturer shall provide a reference list of 10 buyers who have purchased the same model.</p> <p>The manufacturer shall include a brochure depicting the serial product described in the quote.</p>	x	
2.0 SAFETY DECLARATION			
<p>Manufacturer will supply a safety declaration which contains at least the following:</p> <ul style="list-style-type: none"> - Manufacturer attests to the safety of the staging environment that its mobile staging products provide for staff, for talent and for the public. - Manufacturer attests that there are no ongoing or past lawsuits that are the result of past or recent accidents caused by any of its products. 			

3.0 Sustainable Development			
	Manufacturer shall be committed to society's need for environmental, recyclable and sustainable manufacturing procedures.	x	
	Manufacturer shall build products in state-of-the-art energy efficient facilities that adhere to strict environmental criteria.	x	
4.0 Mobile Stage Structure:			
<i>4.1 Aluminum Structure</i>	Chassis and stage structure must be made of series 6000 aluminum shall be both designed and custom built by the manufacturer. No aluminum welding will be done on the chassis assembly. These components will be assembled with structural Huck type rivets. Strong, durable, and maintenance free. Exceptional life expectancy of the aluminum structure: 20 years when properly maintained.	x	
<i>4.2 Testing</i>	Prototype shall be field-tested at twice the working load. All manufactured stages shall be quality tested at 1.2 times the working load.	x	
5.0 Hydraulics:			
<i>5.1 Leveling and Set-Up (Hydraulic)</i>	Shall come complete with a fully hydraulic leveling and set up system and double mast lifting mechanism. This is to include the ability to raise the roof with up to 3,800 lb of balanced lighting and sound equipment from stage level to its highest point, in addition to leveling the stage floor. Set up time in less than 30 minutes. No tools required and no hand cranking necessary.	x	
<i>5.2 Double Mast Lifting Mechanism</i>	Shall include one galvanized steel mast per side, for a complete hydraulic set up of stage, sound, lighting and scenic equipment. Masts must be galvanized steel & have minimum dimensions of 7" x 7". Masts must be designed to support combined rigging and wind loads. Each mast is made of three (3) sections and pads. Clearance between encased mast sections and pads must be a maximum of 1/32" according to both main flex axes. Equally, the flex strain caused by an unbalanced roof load of 1,550 lb must be properly compensated and controlled by the pads in order to maintain proper functioning of the lifting system.	x	
<i>5.3 Hydraulic Stabilizers</i>	Shall include a minimum of four (4) hydraulic stabilizers designed to support up to 15,000 lb vertically and 2,000 lb laterally.	x	
<i>5.4 Hydraulic Motor Power</i>	Built in, fuel powered engine for operating the hydraulic system must be provided. No other power source required.	x	

5.5 <i>Hydraulic Security and Safety</i>	Hydraulic system shall include a secondary locking mechanism composed of pins and posts when fully open. The main mast locking pins must be ¾" in diameter. The system shall include safety valves on all hydraulic cylinders. Shall include flow control valves for precise calibration.	x	
5.6 <i>Stage Height from Ground</i>	Hydraulically adjustable from 3'-6" to 4'-3".	x	
6.0 Roof Structure:			
6.1 <i>Trussing</i>	Unit shall be equipped with at least four (4) roof trusses. Trusses shall run the complete width of the stage roof (24'). Trusses to be 2" aluminum tubing for rigging industry standard sound and lighting equipment. Front and rear trusses shall extend at least 1'-10" past the edge of the stage floor. Each front/rear truss shall be able to hold up to 1,200 lb. Two (2) trusses shall be located at the central section of the roof, each capable of holding up to 750 lb balanced or unbalanced load. Shall not require tools, chain hoists or motors.	x	
6.2 <i>Rigging Points</i>	Shall include 24 independent rigging points. Each rigging point shall be able to hold up to 1,500 lb. Four (4) additional points located in front of each corner post with a capacity up to 1,500 lb for rigging PA sound systems shall be available.	x	
6.3 <i>Rigging Bar</i>	Shall include a 2" tubing, aluminum rigging bar of 14' that joins 2 rigging points, close to the roof, at around 4". Rigging bars shall be able to hold 40 lb per linear foot.	x	
6.4 <i>Side Overhang Rigging Beams</i>	Shall include two (2) 6' 6" Side Overhang Rigging Beams with a capacity of 1,500 lb each.	x	
6.5 <i>Roof Structure</i>	Shall be an aluminum frame roof structure. Designed to support 11,400 lb of equipment or 20 psf. Shall not deflect beyond L/180 under live load.	x	
6.6 <i>Roof Covering</i>	Shall consist of a waterproof, gel-coated, UV resistant 1/8" thick fiberglass roof. Fiberglass must be wrapped and molded around the roof structure. No other type of material for roof covering and no other method of wrapping said material around the structure will be considered as equivalent.	x	
6.7 <i>Secondary Roof Support (Corner Posts)</i>	Shall include four (4) corner posts 3" x 3" connecting the roof corners to the stage floor, providing additional safety factor. Designs with posts from roof to ground will be deemed unacceptable.	x	
6.8 <i>Height from stage roof to floor</i>	Upstage clearance of 13'-4". Downstage clearance of 14'-6".	x	

6.9 <i>Roof exceeds Floor</i>	Roof shall overhang the floor surface by at least 42" width and 10" depth, providing protection for the performers and equipment against the elements.	x	
7.0 Stage:			
7.1 <i>Stage Surface</i>	The floor shall be made of ¾" thick birch plywood sheets. Floor shall have a black non-skid surface with high wear resistance and be easy to maintain.	x	
7.2 <i>Reinforced Deck Edges</i>	Shall include aluminum reinforced deck edges to protect entire perimeter of stage surface.	x	
7.3 <i>Stage Width</i>	Shall be no less than 24' from left to right.	x	
7.4 <i>Stage Depth</i>	Shall be no less than 20' from back to front.	x	
7.5 <i>Stage Expandability</i>	Floor space shall be easily increased to 40' x 32', for example by adding optional 4' x 8' or 4' x 4' extension platforms.	x	
7.6 <i>Platform Support Brackets</i>	Shall include support brackets integrated to stage frame for easy installation of optional 4' x 8' or 4' x 4' extension platforms and skirting.	x	
7.7 <i>Quick Leveling Legs</i>	Stage legs and screw jacks shall be rated at a minimum of 10,000 lb. Adjustable height shall address irregular terrain and permit installing stage at 4' 3" high.	x	
7.8 <i>Adjustable Stairway</i>	Shall be aluminum, 6" adjustable and a minimum width of 3'. Shall include two (2) handrails. Shall have Teflon sliders for handling on deck surface.	x	
7.9 <i>Stage Guardrails (removable)</i>	Lightweight, aluminum guardrails must mount to stage edge to protect the sides and back of the upstage area. Guardrails shall be tested at 400 lb	x	
7.10 <i>Work Lighting</i>	Shall include at least four (4) LED work lights, with controls at stage level and powered by an integrated battery.	x	
7.11 <i>Floor Structure</i>	Shall resist at least 150 psf.	x	
7.12 <i>Complete Stage Set Up</i>	Shall not require hand tools. No chain hoists or motors and no hand cranking required. Average set up time approximately 45 minutes.	x	
7.13 <i>Electrical system</i>	The electrical system shall be powered by a deep cycle battery, integrated into the stage. Three (3) methods of recharge shall be available: the towing vehicle's alternator, an external AC power source and boosting terminals.	x	

8.0 Trailer:			
<i>8.1 Towing Vehicle</i>	Can be pulled with a pick up truck or a commercial tractor.	x	
<i>8.2 Unit Weight</i>	Shall be under 10,000 lbs unladen.	x	
<i>8.3 Extra Cargo Capacity</i>	In closed position the trailer shall have at least 766 cu. ft. of storage area where up to 5,000 lb of extra cargo can be stored for transport.	x	
<i>8.4 Trailer Height</i>	Shall have a maximum height of 11'-1".	x	
<i>8.5 Trailer Lights</i>	Must be fitted with LED lights.	x	
<i>8.6 Hitch Mechanism</i>	Shall be equipped with drawbar and pintle eye or ball coupler as standard.	x	
<i>8.7 Leaf Spring Axles</i>	Suspension shall be provided by two (2) leaf spring axles. Shall be easy to inspect - 16,000 lb capacity.	x	
<i>8.8 Tires</i>	Four (4) 16" tires.	x	
<i>8.9 Spare Tire</i>	Shall come with a full size spare tire on standard rim complete with integrated storage.	x	
<i>8.10 Brakes</i>	Shall include electric brakes on all wheels and emergency breakaway system required by DOT.	x	
<i>8.11 Storage Compartment</i>	Shall provide a compartment for storage within reach in closed position. Minimum dimensions of 18" x 18" x 16".	x	
<i>8.12 Tie Downs</i>	Shall include a minimum of ten (10) tie downs for fastening cargo.	x	
9.0 Standards:			
<i>9.1 Full Conformity to Applicable Regulations</i>	Manufacturer shall comply with ICC, IBC, SAE, DOT, NFPA-701, NBC-2005, ULC S-109 and all welding must be CWB certified and inspected by an independent firm according to CSA 47.1 and 47.2 norms or equivalent. Manufacturer shall provide Engineering Certification for the State or the Province where the sale will take place.	x	
<i>9.2 Wind Resistance</i>	Shall withstand sustained winds of no less than 115 mph without windwall and up to 77 mph with windwall installed. Inferior safety factor in resisting wind is deemed unacceptable.	x	
<i>9.3 Vertical Load</i>	Floor: 150 psf. / Roof: 20 psf.	x	
<i>9.4 Rigging Load</i>	Up to 11,400 lb net roof capacity with sound wings.	x	
<i>9.5 Training / Certification</i>	Three (3) day Comprehensive Training Program	x	

10.0 Documentation:			
<i>10.1 Operations Manuals</i>	Two (2) complete operations manuals.	x	
<i>10.2 Certification / Drawings</i>	Drawings shall be indicative of specifications. Shall include stamped certification from a licensed engineer, stating that the stage meets the required safety standards as per the International Building Code of 2018 and the National Building Code of 2010 for live loads, permanent loads, point loads and wind resistance. Certificate for the State or the Province from a licensed engineer shall be provided with the bid.	x	
<i>10.3 Set up Video</i>	Video showing set up and operation shall be available upon request.	x	
11.0 Service:			
<i>11.1 Warranty</i>	Warranty shall cover the stage for a minimum of one (1) year from the date of acceptance by the City, including all hydraulic components, mechanical devices, electric brakes, axles and hitch mechanism, and all items not considered under normal wear and tear. A sample of the warranty shall be included with bid proposal.	x	
<i>11.2 After Sales Service</i>	1-800 Hotline for 24-hour technical support.	x	
<i>11.3 Parts & spares</i>	Shall stock all standard wear components and spare parts for a period of at least 10 years.	x	
12.0 OPTIONS TO BE INCLUDED:			
<i>12.1 Scrim Backdrop</i>	A 70% mesh material allowing for air to pass through the windwall while still providing a measure of protection from the elements. NFPA.-701 and ULC S-109 approved.	x	
<i>12.2 Vinyl Skirting</i>	Shall be weatherproof, fire retardant, skirting for front and sides of the stage. Shall be made of 18 oz. black vinyl and be quick to install. NFPA.-701 and ULC S-109 approved.	x	
<i>12.3 Reinforced Flybays</i>	Reinforced flybays with a capacity of 1,500 lb each to hang sound equipment and video wall.	x	
<i>12.4 Lateral Banner Supports</i>	Shall include one (1) lateral banner support with a lower bar banner tie down on each side which accepts lateral banners of 6' 6" x 15' 10". Shall include pulley rigging points for retractable banner system.	x	

12.5 <i>Rooftop Banner Supports</i>	Shall include 7 vertical posts easily mounted to the roof edge and shall accept banners of 3' 10" x 37'. No tools required.	x	
12.6 <i>Banner Framing Bars</i>	Shall include a set of horizontal aluminum slide-in tracks which allows for straight and improved esthetic installation of rooftop banners.	x	
12.7 <i>Hitch Options</i>	Shall include a drawbar with a 2 5/16" ball coupler.	x	
12.8 <i>Loading Ramp and Storage</i>	Shall be 12' x 3' lightweight aluminum that locates to the stage perimeter. An underfloor ramp storage system for ease of access must be available.	x	
12.9 <i>Storage Compartment</i>	Shall include a steel storage compartment underneath the trailer 14" x 16" x 36"	x	
12.10 <i>Spares Kit</i>	Shall include a spares kit comprising of a variety of optimal pins, engine draw cable.	x	
12.11 <i>Underfloor Storage</i>	Shall include an under-stage floor storage system to accommodate banner supports and line array supports for immediate and easy access during set up.	x	
12.12 <i>Delivery & Training</i>	Shall include delivery to Moab, Utah and a comprehensive 3 day training course for up to 4 technicians in Moab, Utah.	x	

Stageline SL100 Mobile Stage

Floor Size: 24' x 20'
 Wind Resistance: 115 mph without windwalls
 Trailer Weight: 9,990 lb



Standard Equipment *	\$	132,500
Options & accessories	\$	12,825
Services	\$	16,265
Sub-Total	\$	161,590
 Total	 \$	 161,590

All prices are in USD
 Taxes not included (if applicable)
 Payment terms: 30% to confirm, balance prior to departure

Approval

Date:
Signature:
Name:
EIN # (if applicable):

STANDARD EQUIPMENT *

ROOF STRUCTURE & RIGGING

4 Built-in trusses / aluminum 2" diameter tube trussing	Compatible with industry clamps
24 Built-in rigging points - 4 movable rigging brackets included	Capacity: up to 1,500lb
Rigging bar / 14' - spans 2 rigging points from left to right	Capacity: 30 lb / ft
2 side overhang rigging trusses 6'	Capacity: 1500 lb per side
Rigging points in front of corner posts	Capacity: 1500 lb per side
4 Aluminum corner posts	Added roof stability and safety
Fiberglass roof molded and wrapped around structure - black roof	
Rigging load capacity tested at twice the working load	
Total roof load capacity with sound wings:	11,400 lb
Galvanized steel column - one on each side	System safely hoists rigged loads
Reversible as standard	Downstage will reverse in difficult to access venues

HYDRAULICS

Double mast lifting mechanism (for a fully hydraulic set up of the stage, roof, sound, lighting and other equipment)	Lifting Capacity: 3,800 lb - balanced load
High power integrated hydraulic system	Equipped with safety valves on all cylinders
4 Hydraulic stabilizers / stage levels from 3' 6" to 4' 3"	No tools required
Vertical support capacity (each): 15,000 lb	
Lateral support capacity (each): 2,000 lb	
Gas engine	No other power source required

STAGE

Plywood, black finish, non slip / quick levelling legs	24' x 20'
Multifunctional extruded aluminum deck edges	To install decks, skirts, guardrails & staircases
Guardrails (stage model) / aluminum	5 x 5' 9" + 2 x 2' 8"
Support brackets built-in for Stageline platforms	Full perimeter
Aluminum stairway - 7 steps - adjustable - 35" wide - with handrails	
4 LED work lights	2 in the roof, 2 on the chassis
Spares kit	

TRAILER

Drawbar with pintle eye	
2 Leaf spring axles	Capacity: 14,990 lb
4 Tires	0.40 m (16")
Electric brakes on all wheels	
Emergency breakaway system	DOT requirement
Spare wheel / full-size rim / integrated storage	
2 Storage bumpers	Protects structure
10 Equipment tie-downs	
Storage weight capacity	GVWR:15,000 lb - adaptable to your requirements
Storage space capacity	23' 10" x 5' 6" x 5' 6" = 720 ft³

STANDARDS & CERTIFICATIONS

Applicable regulations	IBC, SAE, DOT, NFPA, CBC, NBC & CWB
Vertical load:	Floor: 7.18 KPa (150 psf) / Roof: 1 KPa (20 psf)
Wind resistance:	115 mph without windwalls 77 mph with windwalls
Certificate stamped by professional engineers	
All technical documents supplied	
24/7 service support +1(800) 267-8243	

OPTIONS & ACCESSORIES

A	WINDWALLS - SKIRTS	VINYL/ SCRIM	Price (USD)	Quantity
a1	Upstage fire retardant windwall - 44' long x full height (with doors) (keder aluminum track system for easy installation) - black		\$ 5,200	
a2	Backdrop (with doors) - 24' x 15' - black	SCRIM	\$ 2,350	1 \$ 2,350
a3	Downstage windwall extensions - 10' 3" x 15' (with doors) - (Set of 2) - black		\$ 2,850	
a4	Skirting - 40' x 4' 9" - black	VINYL	\$ 1,350	1 \$ 1,350
a5	Skirt extension - 8' 6" - black - (set of 2)		\$ 600	

* for options a1 to a5, select material - also available in grey - fabrication delay
 * if option a3 selected, f1 (keder for windwalls on downstage roof panels) must be selected

B	SOUND WINGS & RIGGING	Price (USD)	Quantity
b1	Extension platforms (black non-slip) & accessories - 4' x 8' - (sugg'd qty: 4)	\$ 990	
b2	Guardrails (platform model) / aluminum - 3' 8" - (sugg'd qty: 8)	\$ 180	
b3	Reinforced flybays with line array and screen rigging points (set of 2)	\$ 1,750	1 \$ 1,750
b4	FOH pipes - capacity: 700 lb - (set of 2)	\$ 1,830	
b5	Movable rigging brackets - (set of 2)	\$ 150	
b6	2 Cylinder locks (corner post substitute)	\$ 500	
b7	PA Extension bars (set of 2)	\$ 450	
b8	Additional rigging bar / 14' - spans 2 rigging points from left to right	\$ 355	

C	BANNER SUPPORTS	Price (USD)	Quantity
c1	Rooftop banner support posts - 37' x 4'	\$ 725	1 \$ 725
c2	Banner framing bars	\$ 450	1 \$ 450
c3	Lateral banner supports - 6' x 15' 10" - includes pulley rigging points for retractable banner system	\$ 800	1 \$ 800
c4	2 Lateral tightening bars / stage level	\$ 900	1 \$ 900

D	EXTEND TO 24' x 24'	Price (USD)	Quantity
d1	3 Extension platforms & accessories - 4' x 24' - upstage	\$ 2,970	
d2	8 Guardrails (platform model) / aluminum - 3' 8" - upstage	\$ 1,440	
d3	Bracing system for extension platforms - upstage	\$ 810	
d4	Windwall to cover increased area - upstage	\$ 540	
d5	Roof extension - vinyl canopy & hardware - 4' 9" / downstage - (b4 required)	\$ 3,200	

E	HYDRAULICS	Price (USD)	Quantity
e1	Hydraulic quick connectors	\$ 450	
e2	Electric motor, 1 hp, 110 V, hydraulic connections and pump for dual power (storage compartment included)	\$ 3,250	
e3	Safety cut off switch	\$ 675	

F	ENHANCED REVERSIBILITY OPTIONS	Price (USD)	Quantity
f1	Keder for windwalls on downstage roof panels	\$ 350	
f2	Multi-purpose, heavy-duty structural connectors for side overhang rigging beams and lateral banners. FOH pipe sliders included.	\$ 2,160	
f3	Reinforced 6' flybay trusses (b3) with all hinged and articulated components on upstage roof panel (set of 2) - f2* required	\$ 4,300	

Note: Options f1, f2 and f3 need to be selected for full reversibility

H	TRAILER HITCH	Price (USD)	Quantity
h1	Gooseneck with kingpin for 5th wheel hookup (instead of drawbar with pintle eye)	\$ 2,100	
h2	Gooseneck with 2 5/16" ball hitch hookup (instead of drawbar with pintle eye)	\$ 2,100	
h3	Hydraulic gooseneck option for h1 or h2	\$ 3,400	
h4	Drawbar with pintle hitch (in addition to gooseneck)	\$ 2,400	
h5	Ball hitch (attachment only)	\$ 1,100	
h6	Drawbar with 2 5/16" ball coupler (instead of drawbar with pintle eye)	-	1

I	ACCESSORIES	Price (USD)	Quantity
i1	Aluminum stairway - 7 steps - adjustable - 35" wide - with handrails	\$ 1,500	
i2	Loading ramp / aluminum - 3' x 12'	\$ 1,325	1 \$ 1,325
i3	Underfloor storage for loading ramp	\$ 675	1 \$ 675
i4	ADA lift - up to 5' - 600 lb max load - portable - access from all sides	\$ 10,770	
i5	Extension platform (black non-slip) & accessories - 4' x 8'	\$ 990	
i5a	Cutout gooseneck extension platform (black non-slip) & accessories - 4' x 8'	\$ 1,495	
i5b	Cutout engine extension platform (black non-slip) & accessories - 4' x 8'	\$ 1,495	
i6	Extension platform (black non-slip) & accessories - 4' x 4'	\$ 800	
i7	Guardrail (platform model) / aluminum - 3' 8"	\$ 180	
i8	Guardrail (stage model) / aluminum - 2' 8"	\$ 160	
i9	Guardrail (stage model) / aluminum - 5' 9"	\$ 320	
i10	Guardrail (stage model) / aluminum - 5 x 5' 9" + 2 x 2' 8"	\$ 1,900	
i11	Quick shelter. polyester roof and walls - 8' x 8'	\$ 1,600	
i12	Quick shelter. polyester roof and walls - 10' x 10'	\$ 1,800	
i13	Storage compartment / aluminum checker plate - 14" x 16" x 36" - up to 3	\$ 875	1 INCLUDED
i14	Additional spares kit	\$ 425	
i15	Underfloor storage system for options and accessories	\$ 2,500	1 \$ 2,500
i16	Skids/skis	\$ 6,650	
i17	Aluminum mags - 16" x 6" 8/6.5 bolt pattern	\$ 1,600	

OPTIONS & ACCESSORIES

K TRAILER GRAPHICS		Price (USD)	Quantity
k1	Logo only	TBD	
k2	Full graphic trailer wrap - (2 x (24' 7" x 7' 2") - 2 x (4' 11" x 7'))	\$ 3,675	
Customized scrim* banners - printed graphics - 4 color process			
k3	Rooftop header banner - 24' x 3' 10"	\$ 970	
k4	Rooftop header banner - 37' x 3' 10" - spans lateral banners	\$ 1,390	
k5	Lateral banners - 6' 6" x 15' 9" (Set of 2)	\$ 1,045	
k6	Rear banner - 23' 4" x 12' 11" - installs full size, with or without backdrop <i>*available in vinyl - prices vary</i>	\$ 2,725	
L MISCELLANEOUS		Price (USD)	Quantity
l1	* Black fiberglass	\$ 1,750	
l2	Misc_2	TBD	
<i>* Possible production delay</i>			
Total for Options & Accessories			\$ 12,825

SERVICES			
SERVICES		Price (USD)	Quantity
m1	Trailer shrink wrap	\$ 700	
m2	Transport to Moab, UT - includes customs paperwork	\$ 9,200	1 \$ 9,200
m2a	Transport to Champlain, NY - includes customs paperwork	\$ 1,200	
m3	Training course - 3 day comprehensive (subject to options chosen) - maximum 4 technicians	\$ 2,890	1 \$ 2,890
m4	Trainer expenses - to, in & from training site (n/a when training given at Stageline)	\$ 4,175	1 \$ 4,175
Total for Services			\$ 16,265

*Prices & specifications subject to change without notice Stageline SL100 - Sales Quote 2022



Costs related to transportation, training and trainer expenses (travel, accommodation and per diem) not included.
EXW: L'Assomption, Quebec, Canada

Stageline Mobile Stage Inc.
700 Marsolais Street, L'Assomption, Quebec, Canada J5W 2G9

Tel.: (450) 589-1063, Fax: (450) 589-1711
www.stageline.com

SL100

BENEFITS

STAGELINE SL100

The roof membrane is fiberglass moulded and bonded on to the roof structure, is thick and resistant. No maintenance or replacement required for the lifespan of the stage.

All Stageline products have several safety features during and after installation, eg. column and stabilizer locking pins and safety block valves on all cylinders for a safe and secure system.

Heavy duty yet uncomplicated hydraulic rams are used to lift the roof structure and open the two roof panels seamlessly.

Stageline's Cross Lift Technology allows for equipment to be loaded uneven and includes a double-mast mechanism that lifts unbalanced loads.

Stageline mobile stages are world renowned products with over 400 x SL100 models all over the world.

The SL100 has a wind resistance of 115mph as defined by independent engineers, McLaren Engineering Group and therefore adheres to The IBC 2018 code.

The SL100 comes complete with a 6' 6" Rigging bar with several rigging points, that can hold a sound system and a video wall. Plus, you can rig in front of the corner posts.

The SL100 can lift 3,800lb of weight with equipment loaded at a safe working height.

BROCHURE

See full brochure issued separately



PLANES TRAINS and BBQ

SL100

THE SL100
IN A CLASS OF ITS OWN

STAGE
LINE

Photo: Scott Thompson / StageRent.com

TECHNICAL FACTORS

WARRANTY – see sample Warranty certificate

Stageline provide the Stage Care warranty program with the following coverage:

1 year standard coverage free from material defects in workmanship and labor from the date of delivery, and

3 years extended coverage on all aluminum welded structure including chassis, and

5 years extended covered on the Fiber-Lock roof covering

In the event of a material defect within the prescribed warranty period, Seller will repair the stage. Seller shall be solely responsible for the cost of all warranty parts and labor. No warranty is given by Seller with respect to fabrics, tires or rubber roof joints, or normal wear and tear.

This warranty, unique to Stageline, is offered at no extra cost!

MAINTENANCE – annual requirements and manufacturer’s associated programs

The annual maintenance on the SL100 is minimal. Practical maintenance logs are supplied and are used to keep tabs on maintenance such as lubrication of moving parts, painting, engine care along with regular trailer upkeep.

ANNUAL INSPECTION – see Inspection Program document

An annual inspection can be performed by Stageline on your SL100 consisting of analysis of the 4 major technologies integrated into all Stageline products (trailer structure, hydraulics, structural and mechanical engineering – plus the scenic technology) along with efficient operation of all systems.

A detailed Technical Inspection Report, including all technical recommendations, is issued following the stage inspection.

A service offer can also be provided to perform the maintenance activities prescribed on the Technical Inspection Report.

SL 100 // TECHNICAL

DRAWINGS

MASS & DIMENSIONS

Trailer Hitch Option A
Drawbar / Pintle Eye

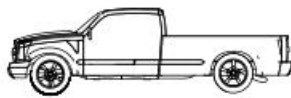
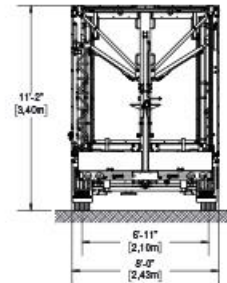
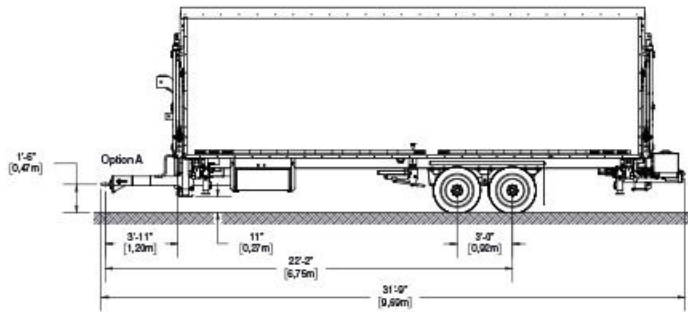

Mass SL100	Unladen		Standard Equipment		Maximum Capacity	
	Lbs	Kg	Lbs	Kg	Lbs	Kg
Total Mass	9460	4290	11682	5298	15000	6804
Mass on Axle	8159	3700	10295	4669	14000	6350
Mass on Hitch	1301	590	1387	627	3750	1701

MASS & DIMENSIONS

Trailer Hitch Option B
King Pin / Fifth Wheel

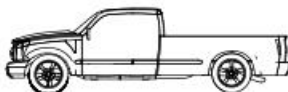
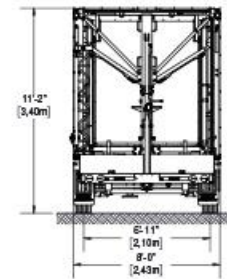
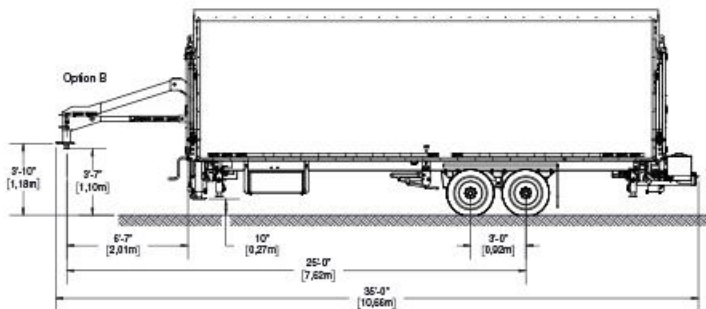

Mass SL100	Unladen		Standard Equipment		Maximum Capacity	
	Lbs	Kg	Lbs	Kg	Lbs	Kg
Total Mass	9460	4290	11682	5298	15000	6804
Mass on Axle	8159	3700	10295	4669	14000	6350
Mass on Hitch	1301	590	1387	627	3750	1701

SL 100 // TECHNICAL

DRAWINGS

FRONT VIEW

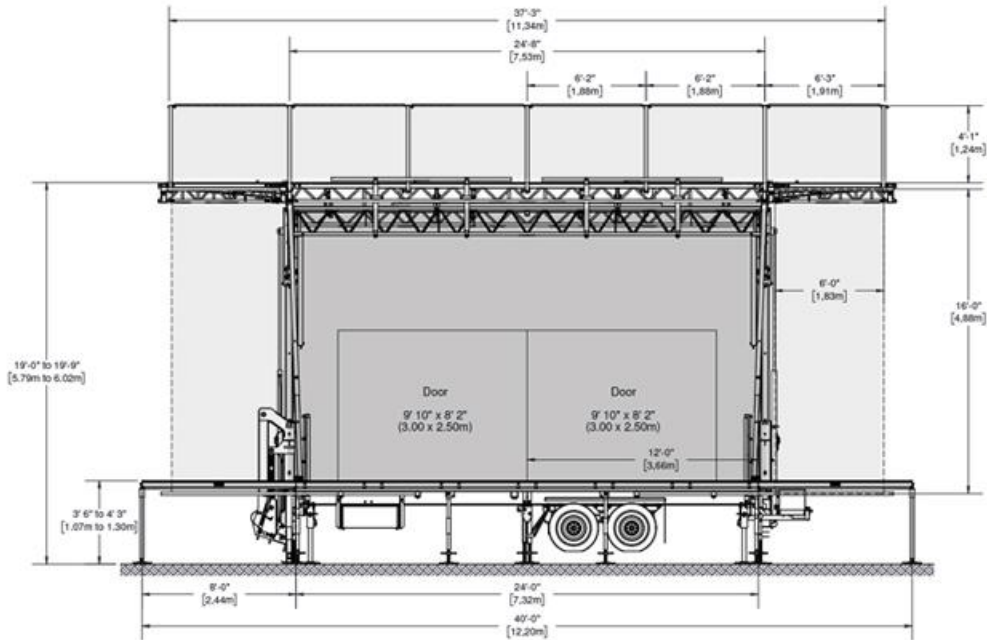

SIDE VIEW

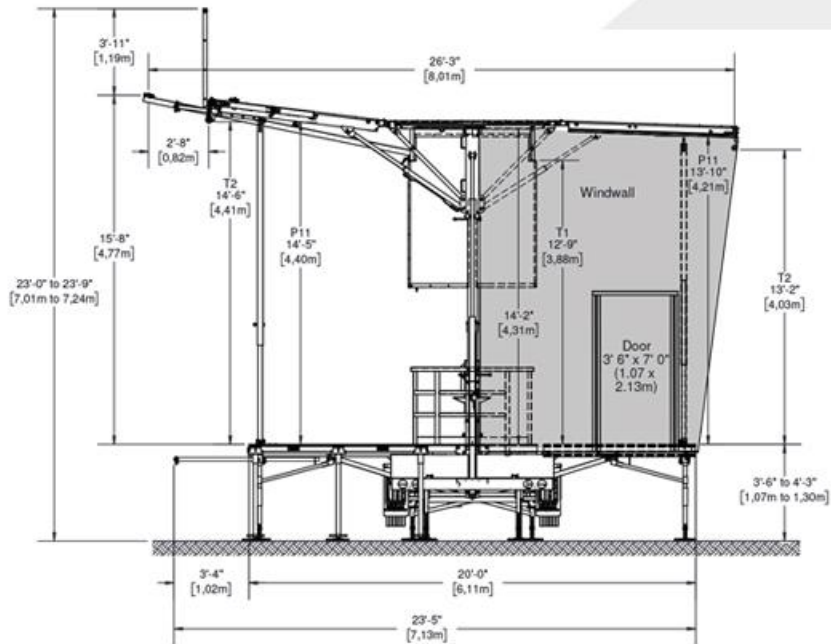

DRAWINGS

EXTENSION PLATFORM LAYOUTS

Bandshell Configurations *

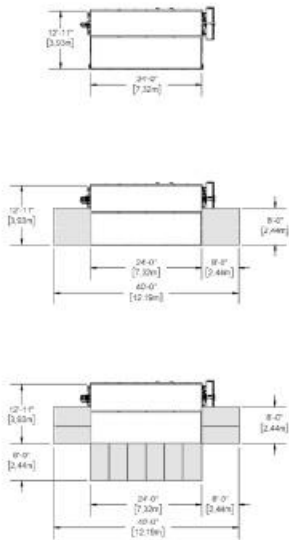

Standard Configurations

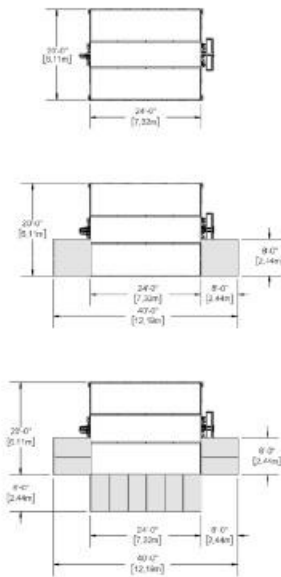

Extended Configurations

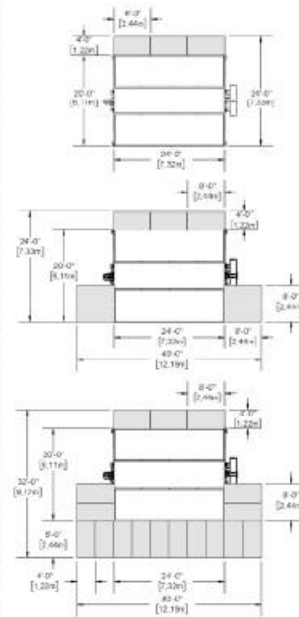

A THOROUGH UNDERSTANDING OF THE INTER-RELATED LOADINGS SHOWN IN THIS RIGGING PLAN IS NEEDED IN ORDER TO SAFELY USE THIS MOBILE STAGE ROOF AND TAKE FULL ADVANTAGE OF THE MANY RIGGING OPPORTUNITIES IT OFFERS.

This mobile stage roof offers a variety of rigging options with regard to load capacity, placement and type.

There are rigging pipes, trusses, roof rigging points and side overhang rigging beams.

This rigging plan locates and defines these rigging features, includes load capacity for each and describes maximum combinations of loads amongst features.

Take note of exclusions, maximum sub-totals in a group, load balance requirements, maximum lifting capacity of roof and maximum rigging load on roof.

The maximum load on the roof is less than the sum of the maximum load on each rigging feature.

Refer to Operator's Manual for procedures in regards to proper setup and setup methods of the stage and its options.

RIGGING PLAN 1/7

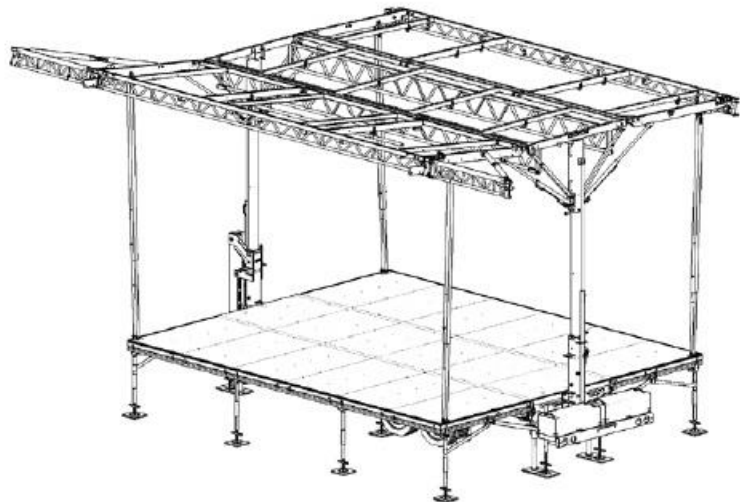

PHOTOS



PHOTOS





ENGINEERING STAMPS



Structural | Civil + Site | Marine + Coastal
Bridge, Highway + Rail | Entertainment | Geotechnical
Facade + Building Envelope | Construction Engineering
Forensic Investigation | Surveying + Mapping

January 1, 2022 *

Stageline Mobile Stage Inc.
700 Marsolais Street
L'Assomption, Quebec, Canada, J5W 2G9

Attn: Mr. Yvan Miron

Email: Yvan.Miron@stageline.com

Re: SL100 (2018) Mobile Stage – Use in the United States
McLaren File No. 103096 Phase 40

Dear Mr. Miron,

McLaren Technical Services, Inc. (McLaren) has reviewed the SL100 Mobile Stage system 2018 version for general use in the United States. The calculations and drawings were produced under the supervision and responsible charge of the undersigned. The final documents are the result of a comprehensive evaluation by McLaren and include approved revisions as needed resulting from these engineering reviews. **We believe that the erected system will safely support the approved loading and environmental conditions if properly assembled and used in accordance with manufacturer's recommendations and as noted herein.**





The assessment by McLaren only considers the fully erected SL100 (2018) Mobile Stage structure and its standard features, including wind walls, side overhangs, front-of-house rigging trusses, and optional extension floors. Additional items such as auxiliary components, side platforms, access ramp, hydraulic systems and erection devices were not considered in this review. The fabrication, design and operational procedures meet or exceed the requirements of ANSI E1.21-2020 "Entertainment Technology – Temporary Structures Used for Technical Production of Outdoor Entertainment Events." The design loads were derived from ASCE 7 and ANSI E1.21. Steel design was performed using AISC-LRFD provisions. Plywood was designed using APA provisions.

The design and construction of the erected stage assembly meets the applicable requirements of IBC-2018 Chapter 16, with the following suitable adjustments:

1. The mobile stage is erected for a very short period of time and protective actions must be taken by trained personnel under specified environmental conditions. Environment loads in ASCE 7 and IBC, including wind, are based on statistical probabilities that relate to time. Reductions in design loads have been taken using the provisions of ANSI E1.21 to account for such conditions. The wind design load capacity for the mobile stage far exceeds the required by ANSI E1.21.

SAMPLE

* Engineering stamps must be renewed on an annual basis. States of CA, HI, NV, and WA expire throughout the calendar year and need to be renewed accordingly.

<p>South Carolina</p>  <p>Malcolm G. McLaren, P.E. SC PE #16783</p> <p>Texas</p>  <p>William B. Gorlin, P.E. TX PE#122574</p> <p>Virginia</p>  <p>Malcolm G. McLaren Lic. No. 9787</p> <p>Malcolm G. McLaren, P.E. VA PE#9787</p>	<p>South Dakota</p>  <p>William B. Gorlin, P.E. SD PE #13438</p> <p>Utah</p>  <p>William B. Gorlin, S.E. UT SE#188525-2203</p> <p>Washington</p>  <p>William B. Gorlin, P.E. WA PE#53601</p>
------------------------------------------------------------------------------------------------------------------------------------------------------------------------------------------------------------------------------------------------------------------------------------------------------------------------------------------------------------------------------------------------------------------------------------------------------------------------------------------------------------------	-------------------------------------------------------------------------------------------------------------------------------------------------------------------------------------------------------------------------------------------------------------------------------------------------------------------------------------------------------------------------------------------------------------------------------------------------------------------------



WARRANTY

The seller represents and warrants that the **Stageline SL100** stage will be under the Stageline stage care program with the following coverage:

1 YEAR

Standard coverage: free from material defects in workmanship and labor from the date of delivery.

3 YEARS

Extended coverage: all aluminum welded structures including chassis.

5 YEARS

Extended coverage: fiber-lock roof covering.

IN THE EVENT OF A MATERIAL DEFECT WITHIN THE PRESCRIBED WARRANTY PERIOD, SELLER WILL REPAIR THE STAGE. SELLER SHALL BE SOLELY RESPONSIBLE FOR THE COST OF ALL WARRANTY PARTS AND LABOR. No WARRANTY IS GIVEN BY SELLER WITH RESPECT TO FABRICS, TIRES OR THE RUBBER ROOF JOINTS, OR NORMAL WEAR AND TEAR.

Recording Date: __/__/__

The warranty becomes effective immediately upon completion of the Stageline training program.

By:  _____



SAFETY

DECLARATION



STAGELINE — MANUFACTURER

Stageline products are entirely fabricated and assembled in our manufacturing plant. Less than 20% of the product is fabricated by sub-contractors. A large amount of materials are sourced from the USA.

SAFETY RECORD

Spanning over 32 years with front line participation in more than one hundred thousand events, Stageline activity remains exemplary. There has been no incident causing an injury due to a breakdown of equipment.

SAFE STAGING ENVIRONMENT

We hereby attest that the environment during, and resulting from, the deployment of Stageline mobile stages is safe for staff, talent, for the public as well as gear and equipment.

LEGAL

Stageline attests that there are no ongoing or past lawsuits that are the result of past or recent accidents caused by any of its products.

A handwritten signature in blue ink, appearing to read "PLR", written over a horizontal line.

PIERRE-LUC ROMPRE
Commercial Director & COO



CORPORATE PROFILE

BUSINESS TYPE

Designer and manufacturer

BUSINESS STORY

With over 32 years of proven success in the outdoor entertainment and staging industry, Stageline is renowned around the world as the leader in the design and manufacture of mobile hydraulic stages.

CONTACTS

Yvan Miron | President & Ceo

Pierre-Luc Rompré | Commercial Director & Coo

Marius Chouinard | Technical Director

Jonathan Doucet | Engineering Director

Simon Normandeau | Customer Service Director



EMPLOYEES

182 employees (full time)



FACILITIES

Head office and two manufacturing plants

PRODUCTS

SL75, SL100, SL100 Mix, SL260, SL320, SAM555, SAM575 & SAM750,
Covered Wings & Backstage

Promobile | Mobile Space & Display Units

HyTower

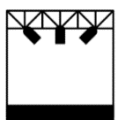

CORPORATE PROFILE



CERTIFICATIONS

All documentation available upon request



TECHNOLOGIES

Scenic Engineering
Hydraulics

Structural And Mechanical Engineering
Transportation

PARTIAL LIST OF CLIENTS — TOWNS & CITIES

Borough of Seaside Heights	NJ	Town Of Cary	NC
City Of Carlsbad	CA	City Of Boston	MA
City Of Cold Lake	AB	Township of Long Beach	NJ
City Of Sulphur Springs	TX	City Of Halifax	NS
City Of Brampton	ON	Great Neck Park District	NY
City Of Rome	NY	City Of New York	NY
Town of Estes Park	CO	City Of Cleveland	MS
Township of Hadden	NJ	City Of Fernie	BC
City Of El Centro	CA	City Of Burlington	ON
Ville De Repentigny	QC	County of Mercer	NJ
City Of Thunder Bay	ON	Village Of Lake George	NY
City Of Sunrise	FL	Town Of Niagara	NY
City Of Grand Prairie	TX	Ville De Blainville	QC

OVER 1,000 MOBILE STAGES BUILT TO DATE

PROOF OF INSURANCE

EVIDENCE OF INSURANCE

THIS IS TO CERTIFY THAT THE POLICIES OF INSURANCE LISTED BELOW HAVE BEEN ISSUED TO THE NAMED INSURED HEREIN FOR THE POLICY PERIOD INDICATED. NOTWITHSTANDING ANY REQUIREMENT, TERM OR CONDITION OF ANY CONTRACT OR OTHER DOCUMENT WITH RESPECT TO WHICH THIS DOCUMENT MAY BE ISSUED OR MAY PERTAIN, THE INSURANCE AFFORDED BY THE POLICIES DESCRIBED HEREIN IS SUBJECT TO ALL THE TERMS, CONDITIONS AND EXCLUSIONS OF SUCH POLICIES.

THIS DOCUMENT IS ISSUED AS A MATTER OF INFORMATION ONLY AND CONFERS NO RIGHTS UPON THE HOLDER. THIS EVIDENCE OF INSURANCE DOES NOT AMEND, EXTEND OR ALTER THE COVERAGE AFFORDED BY THE POLICY(IES) BELOW. THIS EVIDENCE OF INSURANCE DOES NOT CONSTITUTE A CONTRACT BETWEEN THE ISSUING INSURER(S), AUTHORIZED REPRESENTATIVE OR PRODUCER, AND THE HOLDER. LIMITS SHOWN MAY HAVE BEEN REDUCED BY PAID CLAIMS.

NAMED INSURED	INSURANCE BROKER
Stageline Mobile Stage Inc. 827 L'Ange-Gardien Blvd. L'Assomption, QC J5W1T3	HUB International Limitée. 8500, boulevard Décarie, 5 ^e étage Mont-Royal, QC Canada H4P 2N2

EVIDENCE OF INSURANCE NUMBER : 2021-V

REVISION NUMBER :

DATE (YYYY-MM-DD) : 2021-03-29

TYPE OF INSURANCE	INSURER POLICY NUMBER	EFFECTIVE DATE EXPIRY DATE (YYYY-MM-DD)	LIMITS OF INSURANCE	
COMMERCIAL GENERAL LIABILITY <input type="checkbox"/> CLAIMS-MADE FORM <input checked="" type="checkbox"/> OCCURRENCE FORM <input checked="" type="checkbox"/> NON-OWNED AUTOMOBILE (O.P.F. NO. 6) <input checked="" type="checkbox"/> ADDITIONAL INSURED – VENDORS BROAD FORM <input checked="" type="checkbox"/> CONTINGENT EMPLOYER'S LIABILITY – CANADA	AIG Insurance Company of Canada 66458326	2021-03-31 #2 2022-03-31	EACH OCCURRENCE LIMIT PERSONAL & ADVERTISING INJURY LIMIT GENERAL AGGREGATE LIMIT PRODUCTS-COMPLETED OPERATIONS AGGREGATE LIMIT TENANTS' LEGAL LIABILITY LIMIT MEDICAL EXPENSE LIMIT	\$2,000,000 \$2,000,000 \$2,000,000 \$2,000,000 \$1,000,000 \$25,000
AUTOMOBILE LIABILITY (O.P.F. NO. 1) <input type="checkbox"/> NON-OWNED AUTOS <input type="checkbox"/> ALL OWNED AUTOS <input checked="" type="checkbox"/> SCHEDULED AUTOS <input type="checkbox"/> MIXED AUTOS <input type="checkbox"/> ANY AUTO	AIG Insurance Company of Canada 66458343	2021-01-31 #2 2022-01-31	CIVIL LIABILITY – BODILY INJURY TO OR DEATH OF OTHERS OR DAMAGE TO THEIR PROPERTY	\$1,000,000
COMMERCIAL UMBRELLA LIABILITY <input type="checkbox"/> CLAIMS-MADE FORM <input type="checkbox"/> OCCURRENCE FORM	AIG Insurance Company of Canada 66458327	2021-03-31 #2 2022-03-31	EACH OCCURRENCE LIMIT GENERAL AGGREGATE LIMIT PRODUCTS-COMPLETED OPERATIONS AGGREGATE LIMIT	\$3,000,000 \$3,000,000 \$3,000,000
EXCESS LIABILITY <input checked="" type="checkbox"/> OCCURRENCE FORM	Market #CAS614948-02	2021-03-31 #2 2022-03-31	EACH OCCURRENCE LIMIT GENERAL AGGREGATE LIMIT	5,000,000\$ 5,000,000\$

THIS EVIDENCE OF INSURANCE IS ISSUED IN REFERENCE TO:

EVIDENCE OF INSURANCE ISSUED TO: To Whom It May Concern	
	Patrick Bélanger 514.864.5967 AUTHORIZED REPRESENTATIVE

WORKERS' COMPENSATION

CNESST



**SUBJECT: Coverage of workers assigned to work outside of Québec
Act respecting Industrial Accidents and Occupational Diseases (AIAOD) Section 8**

We are pleased to confirm that paid employees of your organization who retain their domicile in Québec throughout the period that they work outside Québec are covered by the above mentioned Law for all occupational injury as defined in the Law.

Paid employees domiciled in Québec at the time of their departure to work outside Québec, but who subsequently cease to be so domiciled, will be covered under the AIAOD for a period of five years from the date of the commencement of their assignment outside Québec.

The CNESST reminds you that AIAOC applies to Québec workers assigned to work outside Québec if, when the occupational injury occurs, the worker has his domicile in Québec and his employer has an establishment in Québec.

However, where the worker's domicile is not in Québec, this Act applies where the worker had his domicile in Québec at the time of his assignment outside Québec, the work outside Québec is for the duration of not over five years when the accident occurs or the disease is contracted, and his employer has an establishment in Québec.

If you require additional information, do not hesitate to contact us.

Sincerely,

CNESST Direction régionale de la Mauricie et du Centre-du-Québec

Commissioner of oaths

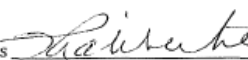
Francine Laliberté



Certificate of Status of Beneficial Owner for United States Tax Withholding and Reporting (Entities)

(Rev. July 2017)
Department of the Treasury
Internal Revenue Service

▶ For use by entities. Individuals must use Form W-8BEN. ▶ Section references are to the Internal Revenue Code.
▶ Go to www.irs.gov/FormW8BENE for instructions and the latest information.
▶ Give this form to the withholding agent or payer. Do not send to the IRS.

Do NOT use this form for:

Instead use Form:

- U.S. entity or U.S. citizen or resident W-9
- A foreign individual W-8BEN (Individual) or Form 8233
- A foreign individual or entity claiming that income is effectively connected with the conduct of trade or business within the U.S. (unless claiming treaty benefits) W-8ECI
- A foreign partnership, a foreign simple trust, or a foreign grantor trust (unless claiming treaty benefits) (see instructions for exceptions) W-8IMY
- A foreign government, international organization, foreign central bank of issue, foreign tax-exempt organization, foreign private foundation, or government of a U.S. possession claiming that income is effectively connected U.S. income or that is claiming the applicability of section(s) 115(2), 501(c), 892, 895, or 1443(b) (unless claiming treaty benefits) (see instructions for other exceptions) W-8ECI or W-8EXP
- Any person acting as an intermediary (including a qualified intermediary acting as a qualified derivatives dealer) W-8IMY

Part I Identification of Beneficial Owner

1 Name of organization that is the beneficial owner STAGELINE MOBILE STAGE INC	2 Country of incorporation or organization CANADA
-------------------------------------------------------------------------------------------------	--------------------------------------------------------------------

3 Name of disregarded entity receiving the payment (if applicable, see instructions)

4 Chapter 3 Status (entity type) (Must check one box only):

<input checked="" type="checkbox"/> Corporation	<input type="checkbox"/> Disregarded entity	<input type="checkbox"/> Partnership
<input type="checkbox"/> Simple trust	<input type="checkbox"/> Estate	<input type="checkbox"/> Government
<input type="checkbox"/> Grantor trust	<input type="checkbox"/> Complex trust	
<input type="checkbox"/> Central Bank of Issue	<input type="checkbox"/> Tax-exempt organization	<input type="checkbox"/> Private foundation
	<input type="checkbox"/> International organization	

If you entered disregarded entity, partnership, simple trust, or grantor trust above, is the entity a hybrid making a treaty claim? If "Yes" complete Part III. Yes No

5 Chapter 4 Status (FATCA status) (See instructions for details and complete the certification below for the entity's applicable status.)

<input type="checkbox"/> Nonparticipating FFI (including an FFI related to a Reporting IGA FFI other than a deemed-compliant FFI, participating FFI, or exempt beneficial owner).	<input type="checkbox"/> Nonreporting IGA FFI. Complete Part XII.
<input type="checkbox"/> Participating FFI.	<input type="checkbox"/> Foreign government, government of a U.S. possession, or foreign central bank of issue. Complete Part XIII.
<input type="checkbox"/> Reporting Model 1 FFI.	<input type="checkbox"/> International organization. Complete Part XIV.
<input type="checkbox"/> Reporting Model 2 FFI.	<input type="checkbox"/> Exempt retirement plans. Complete Part XV.
<input type="checkbox"/> Registered deemed-compliant FFI (other than a reporting Model 1 FFI, sponsored FFI, or nonreporting IGA FFI covered in Part XII). See instructions.	<input type="checkbox"/> Entity wholly owned by exempt beneficial owners. Complete Part XVI.
<input type="checkbox"/> Sponsored FFI. Complete Part IV.	<input type="checkbox"/> Territory financial institution. Complete Part XVII.
<input type="checkbox"/> Certified deemed-compliant nonregistering local bank. Complete Part V.	<input type="checkbox"/> Excepted nonfinancial group entity. Complete Part XVIII.
<input type="checkbox"/> Certified deemed-compliant FFI with only low-value accounts. Complete Part VI.	<input type="checkbox"/> Excepted nonfinancial start-up company. Complete Part XIX.
<input type="checkbox"/> Certified deemed-compliant sponsored, closely held investment vehicle. Complete Part VII.	<input type="checkbox"/> Excepted nonfinancial entity in liquidation or bankruptcy. Complete Part XX.
<input type="checkbox"/> Certified deemed-compliant limited life debt investment entity. Complete Part VIII.	<input type="checkbox"/> 501(c) organization. Complete Part XXI.
<input type="checkbox"/> Certain investment entities that do not maintain financial accounts. Complete Part IX.	<input type="checkbox"/> Nonprofit organization. Complete Part XXII.
<input type="checkbox"/> Owner-documented FFI. Complete Part X.	<input type="checkbox"/> Publicly traded NFFE or NFFE affiliate of a publicly traded corporation. Complete Part XXIII.
<input type="checkbox"/> Restricted distributor. Complete Part XI.	<input type="checkbox"/> Excepted territory NFFE. Complete Part XXIV.
	<input checked="" type="checkbox"/> Active NFFE. Complete Part XXV.
	<input type="checkbox"/> Passive NFFE. Complete Part XXVI.
	<input type="checkbox"/> Excepted inter-affiliate FFI. Complete Part XXVII.
	<input type="checkbox"/> Direct reporting NFFE.
	<input type="checkbox"/> Sponsored direct reporting NFFE. Complete Part XXVIII.
	<input type="checkbox"/> Account that is not a financial account.

6 Permanent residence address (street, apt. or suite no., or rural route). Do not use a P.O. box or in-care-of address (other than a registered address).

700 Rue Marsolais
City or town, state or province. Include postal code where appropriate. **Canada**
L'Assomption, Québec, J5W 2G9
Country

7 Mailing address (if different from above)

City or town, state or province. Include postal code where appropriate. Country

8 U.S. taxpayer identification number (TIN), if required 98-1271085	9a GIIN	b Foreign TIN
--------------------------------------------------------------------------------------	----------------	----------------------

10 Reference number(s) (see instructions)

Part II Disregarded Entity or Branch Receiving Payment. (Complete only if a disregarded entity with a GIIN or a branch of an FFI in a country other than the FFI's country of residence. See instructions.)

- 11 Chapter 4 Status (FATCA status) of disregarded entity or branch receiving payment
 Branch treated as nonparticipating FFI. Reporting Model 1 FFI. U.S. Branch.
 Participating FFI. Reporting Model 2 FFI.
- 12 Address of disregarded entity or branch (street, apt. or suite no., or rural route). **Do not use a P.O. box or in-care-of address** (other than a registered address).

City or town, state or province. Include postal code where appropriate.

Country

- 13 GIIN (if any) _____

Part III Claim of Tax Treaty Benefits (if applicable). (For chapter 3 purposes only.)

- 14 I certify that (check all that apply):
- a The beneficial owner is a resident of Canada within the meaning of the income tax treaty between the United States and that country.
- b The beneficial owner derives the item (or items) of income for which the treaty benefits are claimed, and, if applicable, meets the requirements of the treaty provision dealing with limitation on benefits. The following are types of limitation on benefits provisions that may be included in an applicable tax treaty (check only one; see instructions):
- | | |
|----------------------------------------------------------------------|---------------------------------------------------------------------------------------------------------|
| <input type="checkbox"/> Government | <input type="checkbox"/> Company that meets the ownership and base erosion test |
| <input type="checkbox"/> Tax exempt pension trust or pension fund | <input type="checkbox"/> Company that meets the derivative benefits test |
| <input type="checkbox"/> Other tax exempt organization | <input type="checkbox"/> Company with an item of income that meets active trade or business test |
| <input type="checkbox"/> Publicly traded corporation | <input type="checkbox"/> Favorable discretionary determination by the U.S. competent authority received |
| <input type="checkbox"/> Subsidiary of a publicly traded corporation | <input type="checkbox"/> Other (specify Article and paragraph): _____ |
- c The beneficial owner is claiming treaty benefits for U.S. source dividends received from a foreign corporation or interest from a U.S. trade or business of a foreign corporation and meets qualified resident status (see instructions).
- 15 **Special rates and conditions** (if applicable—see instructions):
 The beneficial owner is claiming the provisions of Article and paragraph V and VII
 of the treaty identified on line 14a above to claim a 0 % rate of withholding on (specify type of income): See attached doc
 Explain the additional conditions in the Article the beneficial owner meets to be eligible for the rate of withholding: See attached document

Part IV Sponsored FFI

- 16 Name of sponsoring entity: _____
- 17 **Check whichever box applies.**
- I certify that the entity identified in Part I:
- Is an investment entity;
 - Is not a QI, WP (except to the extent permitted in the withholding foreign partnership agreement), or WT; **and**
 - Has agreed with the entity identified above (that is not a nonparticipating FFI) to act as the sponsoring entity for this entity.
- I certify that the entity identified in Part I:
- Is a controlled foreign corporation as defined in section 957(a);
 - Is not a QI, WP, or WT;
 - Is wholly owned, directly or indirectly, by the U.S. financial institution identified above that agrees to act as the sponsoring entity for this entity; **and**
 - Shares a common electronic account system with the sponsoring entity (identified above) that enables the sponsoring entity to identify all account holders and payees of the entity and to access all account and customer information maintained by the entity including, but not limited to, customer identification information, customer documentation, account balance, and all payments made to account holders or payees.

Part V Certified Deemed-Compliant Nonregistering Local Bank18 I certify that the FFI identified in Part I:

- Operates and is licensed solely as a bank or credit union (or similar cooperative credit organization operated without profit) in its country of incorporation or organization;
- Engages primarily in the business of receiving deposits from and making loans to, with respect to a bank, retail customers unrelated to such bank and, with respect to a credit union or similar cooperative credit organization, members, provided that no member has a greater than 5% interest in such credit union or cooperative credit organization;
- Does not solicit account holders outside its country of organization;
- Has no fixed place of business outside such country (for this purpose, a fixed place of business does not include a location that is not advertised to the public and from which the FFI performs solely administrative support functions);
- Has no more than \$175 million in assets on its balance sheet and, if it is a member of an expanded affiliated group, the group has no more than \$500 million in total assets on its consolidated or combined balance sheets; and
- Does not have any member of its expanded affiliated group that is a foreign financial institution, other than a foreign financial institution that is incorporated or organized in the same country as the FFI identified in Part I and that meets the requirements set forth in this part.

Part VI Certified Deemed-Compliant FFI with Only Low-Value Accounts19 I certify that the FFI identified in Part I:

- Is not engaged primarily in the business of investing, reinvesting, or trading in securities, partnership interests, commodities, notional principal contracts, insurance or annuity contracts, or any interest (including a futures or forward contract or option) in such security, partnership interest, commodity, notional principal contract, insurance contract or annuity contract;
- No financial account maintained by the FFI or any member of its expanded affiliated group, if any, has a balance or value in excess of \$50,000 (as determined after applying applicable account aggregation rules); and
- Neither the FFI nor the entire expanded affiliated group, if any, of the FFI, have more than \$50 million in assets on its consolidated or combined balance sheet as of the end of its most recent accounting year.

Part VII Certified Deemed-Compliant Sponsored, Closely Held Investment Vehicle

20 Name of sponsoring entity: _____

21 I certify that the entity identified in Part I:

- Is an FFI solely because it is an investment entity described in Regulations section 1.1471-5(e)(4);
- Is not a QI, WP, or WT;
- Will have all of its due diligence, withholding, and reporting responsibilities (determined as if the FFI were a participating FFI) fulfilled by the sponsoring entity identified on line 20; and
- 20 or fewer individuals own all of the debt and equity interests in the entity (disregarding debt interests owned by U.S. financial institutions, participating FFIs, registered deemed-compliant FFIs, and certified deemed-compliant FFIs and equity interests owned by an entity if that entity owns 100% of the equity interests in the FFI and is itself a sponsored FFI).

Part VIII Certified Deemed-Compliant Limited Life Debt Investment Entity22 I certify that the entity identified in Part I:

- Was in existence as of January 17, 2013;
- Issued all classes of its debt or equity interests to investors on or before January 17, 2013, pursuant to a trust indenture or similar agreement; and
- Is certified deemed-compliant because it satisfies the requirements to be treated as a limited life debt investment entity (such as the restrictions with respect to its assets and other requirements under Regulations section 1.1471-5(f)(2)(iv)).

Part IX Certain Investment Entities that Do Not Maintain Financial Accounts23 I certify that the entity identified in Part I:

- Is a financial institution solely because it is an investment entity described in Regulations section 1.1471-5(e)(4)(i)(A), and
- Does not maintain financial accounts.

Part X Owner-Documented FFI

Note: This status only applies if the U.S. financial institution, participating FFI, or reporting Model 1 FFI to which this form is given has agreed that it will treat the FFI as an owner-documented FFI (see instructions for eligibility requirements). In addition, the FFI must make the certifications below.

24a (All owner-documented FFIs check here) I certify that the FFI identified in Part I:

- Does not act as an intermediary;
- Does not accept deposits in the ordinary course of a banking or similar business;
- Does not hold, as a substantial portion of its business, financial assets for the account of others;
- Is not an insurance company (or the holding company of an insurance company) that issues or is obligated to make payments with respect to a financial account;
- Is not owned by or in an expanded affiliated group with an entity that accepts deposits in the ordinary course of a banking or similar business, holds, as a substantial portion of its business, financial assets for the account of others, or is an insurance company (or the holding company of an insurance company) that issues or is obligated to make payments with respect to a financial account;
- Does not maintain a financial account for any nonparticipating FFI; and
- Does not have any specified U.S. persons that own an equity interest or debt interest (other than a debt interest that is not a financial account or that has a balance or value not exceeding \$50,000) in the FFI other than those identified on the FFI owner reporting statement.

Part X Owner-Documented FFI (continued)**Check box 24b or 24c, whichever applies.**

- b I certify that the FFI identified in Part I:
- Has provided, or will provide, an FFI owner reporting statement that contains:
 - (i) The name, address, TIN (if any), chapter 4 status, and type of documentation provided (if required) of every individual and specified U.S. person that owns a direct or indirect equity interest in the owner-documented FFI (looking through all entities other than specified U.S. persons);
 - (ii) The name, address, TIN (if any), and chapter 4 status of every individual and specified U.S. person that owns a debt interest in the owner-documented FFI (including any indirect debt interest, which includes debt interests in any entity that directly or indirectly owns the payee or any direct or indirect equity interest in a debt holder of the payee) that constitutes a financial account in excess of \$50,000 (disregarding all such debt interests owned by participating FFIs, registered deemed-compliant FFIs, certified deemed-compliant FFIs, excepted NFFEs, exempt beneficial owners, or U.S. persons other than specified U.S. persons); and
 - (iii) Any additional information the withholding agent requests in order to fulfill its obligations with respect to the entity.
 - Has provided, or will provide, valid documentation meeting the requirements of Regulations section 1.1471-3(d)(6)(iii) for each person identified in the FFI owner reporting statement.
- c I certify that the FFI identified in Part I has provided, or will provide, an auditor's letter, signed within 4 years of the date of payment, from an independent accounting firm or legal representative with a location in the United States stating that the firm or representative has reviewed the FFI's documentation with respect to all of its owners and debt holders identified in Regulations section 1.1471-3(d)(6)(iv)(A)(2), and that the FFI meets all the requirements to be an owner-documented FFI. The FFI identified in Part I has also provided, or will provide, an FFI owner reporting statement of its owners that are specified U.S. persons and Form(s) W-9, with applicable waivers.

Check box 24d if applicable (optional, see instructions).

- d I certify that the entity identified on line 1 is a trust that does not have any contingent beneficiaries or designated classes with unidentified beneficiaries.

Part XI Restricted Distributor

- 25a (All restricted distributors check here) I certify that the entity identified in Part I:
- Operates as a distributor with respect to debt or equity interests of the restricted fund with respect to which this form is furnished;
 - Provides investment services to at least 30 customers unrelated to each other and less than half of its customers are related to each other;
 - Is required to perform AML due diligence procedures under the anti-money laundering laws of its country of organization (which is an FATF-compliant jurisdiction);
 - Operates solely in its country of incorporation or organization, has no fixed place of business outside of that country, and has the same country of incorporation or organization as all members of its affiliated group, if any;
 - Does not solicit customers outside its country of incorporation or organization;
 - Has no more than \$175 million in total assets under management and no more than \$7 million in gross revenue on its income statement for the most recent accounting year;
 - Is not a member of an expanded affiliated group that has more than \$500 million in total assets under management or more than \$20 million in gross revenue for its most recent accounting year on a combined or consolidated income statement; and
 - Does not distribute any debt or securities of the restricted fund to specified U.S. persons, passive NFFEs with one or more substantial U.S. owners, or nonparticipating FFIs.

Check box 25b or 25c, whichever applies.

I further certify that with respect to all sales of debt or equity interests in the restricted fund with respect to which this form is furnished that are made after December 31, 2011, the entity identified in Part I:

- b Has been bound by a distribution agreement that contained a general prohibition on the sale of debt or securities to U.S. entities and U.S. resident individuals and is currently bound by a distribution agreement that contains a prohibition of the sale of debt or securities to any specified U.S. person, passive NFFE with one or more substantial U.S. owners, or nonparticipating FFI.
- c Is currently bound by a distribution agreement that contains a prohibition on the sale of debt or securities to any specified U.S. person, passive NFFE with one or more substantial U.S. owners, or nonparticipating FFI and, for all sales made prior to the time that such a restriction was included in its distribution agreement, has reviewed all accounts related to such sales in accordance with the procedures identified in Regulations section 1.1471-4(c) applicable to preexisting accounts and has redeemed or retired any, or caused the restricted fund to transfer the securities to a distributor that is a participating FFI or reporting Model 1 FFI securities which were sold to specified U.S. persons, passive NFFEs with one or more substantial U.S. owners, or nonparticipating FFIs.

Part XII Nonreporting IGA FFI26 I certify that the entity identified in Part I:

- Meets the requirements to be considered a nonreporting financial institution pursuant to an applicable IGA between the United States and _____ . The applicable IGA is a Model 1 IGA or a Model 2 IGA; and is treated as a _____ under the provisions of the applicable IGA or Treasury regulations (if applicable, see instructions);

- If you are a trustee documented trust or a sponsored entity, provide the name of the trustee or sponsor _____ .

The trustee is: U.S. Foreign**Part XIII Foreign Government, Government of a U.S. Possession, or Foreign Central Bank of Issue**27 I certify that the entity identified in Part I is the beneficial owner of the payment, and is not engaged in commercial financial activities of a type engaged in by an insurance company, custodial institution, or depository institution with respect to the payments, accounts, or obligations for which this form is submitted (except as permitted in Regulations section 1.1471-6(h)(2)).**Part XIV International Organization**

Check box 28a or 28b, whichever applies.

28a I certify that the entity identified in Part I is an international organization described in section 7701(a)(18).b I certify that the entity identified in Part I:

- Is comprised primarily of foreign governments;
- Is recognized as an intergovernmental or supranational organization under a foreign law similar to the International Organizations Immunities Act or that has in effect a headquarters agreement with a foreign government;
- The benefit of the entity's income does not inure to any private person; and
- Is the beneficial owner of the payment and is not engaged in commercial financial activities of a type engaged in by an insurance company, custodial institution, or depository institution with respect to the payments, accounts, or obligations for which this form is submitted (except as permitted in Regulations section 1.1471-6(h)(2)).

Part XV Exempt Retirement Plans

Check box 29a, b, c, d, e, or f, whichever applies.

29a I certify that the entity identified in Part I:

- Is established in a country with which the United States has an income tax treaty in force (see Part III if claiming treaty benefits);
- Is operated principally to administer or provide pension or retirement benefits; and
- Is entitled to treaty benefits on income that the fund derives from U.S. sources (or would be entitled to benefits if it derived any such income) as a resident of the other country which satisfies any applicable limitation on benefits requirement.

b I certify that the entity identified in Part I:

- Is organized for the provision of retirement, disability, or death benefits (or any combination thereof) to beneficiaries that are former employees of one or more employers in consideration for services rendered;
- No single beneficiary has a right to more than 5% of the FFI's assets;
- Is subject to government regulation and provides annual information reporting about its beneficiaries to the relevant tax authorities in the country in which the fund is established or operated; and
 - Is generally exempt from tax on investment income under the laws of the country in which it is established or operates due to its status as a retirement or pension plan;
 - Receives at least 50% of its total contributions from sponsoring employers (disregarding transfers of assets from other plans described in this part, retirement and pension accounts described in an applicable Model 1 or Model 2 IGA, other retirement funds described in an applicable Model 1 or Model 2 IGA, or accounts described in Regulations section 1.1471-5(b)(2)(i)(A));
 - Either does not permit or penalizes distributions or withdrawals made before the occurrence of specified events related to retirement, disability, or death (except rollover distributions to accounts described in Regulations section 1.1471-5(b)(2)(i)(A) (referring to retirement and pension accounts), to retirement and pension accounts described in an applicable Model 1 or Model 2 IGA, or to other retirement funds described in this part or in an applicable Model 1 or Model 2 IGA); or
 - Limits contributions by employees to the fund by reference to earned income of the employee or may not exceed \$50,000 annually.

c I certify that the entity identified in Part I:

- Is organized for the provision of retirement, disability, or death benefits (or any combination thereof) to beneficiaries that are former employees of one or more employers in consideration for services rendered;
- Has fewer than 50 participants;
- Is sponsored by one or more employers each of which is not an investment entity or passive NFFE;
- Employee and employer contributions to the fund (disregarding transfers of assets from other plans described in this part, retirement and pension accounts described in an applicable Model 1 or Model 2 IGA, or accounts described in Regulations section 1.1471-5(b)(2)(i)(A)) are limited by reference to earned income and compensation of the employee, respectively;
- Participants that are not residents of the country in which the fund is established or operated are not entitled to more than 20% of the fund's assets; and
- Is subject to government regulation and provides annual information reporting about its beneficiaries to the relevant tax authorities in the country in which the fund is established or operates.

Part XV Exempt Retirement Plans *(continued)*

- d I certify that the entity identified in Part I is formed pursuant to a pension plan that would meet the requirements of section 401(a), other than the requirement that the plan be funded by a trust created or organized in the United States.
- e I certify that the entity identified in Part I is established exclusively to earn income for the benefit of one or more retirement funds described in this part or in an applicable Model 1 or Model 2 IGA, or accounts described in Regulations section 1.1471-5(b)(2)(i)(A) (referring to retirement and pension accounts), or retirement and pension accounts described in an applicable Model 1 or Model 2 IGA.
- f I certify that the entity identified in Part I:
- Is established and sponsored by a foreign government, international organization, central bank of issue, or government of a U.S. possession (each as defined in Regulations section 1.1471-6) or an exempt beneficial owner described in an applicable Model 1 or Model 2 IGA to provide retirement, disability, or death benefits to beneficiaries or participants that are current or former employees of the sponsor (or persons designated by such employees); or
 - Is established and sponsored by a foreign government, international organization, central bank of issue, or government of a U.S. possession (each as defined in Regulations section 1.1471-6) or an exempt beneficial owner described in an applicable Model 1 or Model 2 IGA to provide retirement, disability, or death benefits to beneficiaries or participants that are not current or former employees of such sponsor, but are in consideration of personal services performed for the sponsor.

Part XVI Entity Wholly Owned by Exempt Beneficial Owners

- 30 I certify that the entity identified in Part I:
- Is an FFI solely because it is an investment entity;
 - Each direct holder of an equity interest in the investment entity is an exempt beneficial owner described in Regulations section 1.1471-6 or in an applicable Model 1 or Model 2 IGA;
 - Each direct holder of a debt interest in the investment entity is either a depository institution (with respect to a loan made to such entity) or an exempt beneficial owner described in Regulations section 1.1471-6 or an applicable Model 1 or Model 2 IGA.
 - Has provided an owner reporting statement that contains the name, address, TIN (if any), chapter 4 status, and a description of the type of documentation provided to the withholding agent for every person that owns a debt interest constituting a financial account or direct equity interest in the entity; and
 - Has provided documentation establishing that every owner of the entity is an entity described in Regulations section 1.1471-6(b), (c), (d), (e), (f) and/or (g) without regard to whether such owners are beneficial owners.

Part XVII Territory Financial Institution

- 31 I certify that the entity identified in Part I is a financial institution (other than an investment entity) that is incorporated or organized under the laws of a possession of the United States.

Part XVIII Excepted Nonfinancial Group Entity

- 32 I certify that the entity identified in Part I:
- Is a holding company, treasury center, or captive finance company and substantially all of the entity's activities are functions described in Regulations section 1.1471-5(e)(5)(i)(C) through (E);
 - Is a member of a nonfinancial group described in Regulations section 1.1471-5(e)(5)(i)(B);
 - Is not a depository or custodial institution (other than for members of the entity's expanded affiliated group); and
 - Does not function (or hold itself out) as an investment fund, such as a private equity fund, venture capital fund, leveraged buyout fund, or any investment vehicle with an investment strategy to acquire or fund companies and then hold interests in those companies as capital assets for investment purposes.

Part XIX Excepted Nonfinancial Start-Up Company

- 33 I certify that the entity identified in Part I:
- Was formed on (or, in the case of a new line of business, the date of board resolution approving the new line of business) _____ (date must be less than 24 months prior to date of payment);
 - Is not yet operating a business and has no prior operating history or is investing capital in assets with the intent to operate a new line of business other than that of a financial institution or passive NFFE;
 - Is investing capital into assets with the intent to operate a business other than that of a financial institution; and
 - Does not function (or hold itself out) as an investment fund, such as a private equity fund, venture capital fund, leveraged buyout fund, or any investment vehicle whose purpose is to acquire or fund companies and then hold interests in those companies as capital assets for investment purposes.

Part XX Excepted Nonfinancial Entity in Liquidation or Bankruptcy

- 34 I certify that the entity identified in Part I:
- Filed a plan of liquidation, filed a plan of reorganization, or filed for bankruptcy on _____;
 - During the past 5 years has not been engaged in business as a financial institution or acted as a passive NFFE;
 - Is either liquidating or emerging from a reorganization or bankruptcy with the intent to continue or recommence operations as a nonfinancial entity; and
 - Has, or will provide, documentary evidence such as a bankruptcy filing or other public documentation that supports its claim if it remains in bankruptcy or liquidation for more than 3 years.

Part XXI 501(c) Organization

- 35 I certify that the entity identified in Part I is a 501(c) organization that:
- Has been issued a determination letter from the IRS that is currently in effect concluding that the payee is a section 501(c) organization that is dated _____; or
 - Has provided a copy of an opinion from U.S. counsel certifying that the payee is a section 501(c) organization (without regard to whether the payee is a foreign private foundation).

Part XXII Nonprofit Organization

- 36 I certify that the entity identified in Part I is a nonprofit organization that meets the following requirements:
- The entity is established and maintained in its country of residence exclusively for religious, charitable, scientific, artistic, cultural or educational purposes;
 - The entity is exempt from income tax in its country of residence;
 - The entity has no shareholders or members who have a proprietary or beneficial interest in its income or assets;
 - Neither the applicable laws of the entity's country of residence nor the entity's formation documents permit any income or assets of the entity to be distributed to, or applied for the benefit of, a private person or noncharitable entity other than pursuant to the conduct of the entity's charitable activities or as payment of reasonable compensation for services rendered or payment representing the fair market value of property which the entity has purchased; and
 - The applicable laws of the entity's country of residence or the entity's formation documents require that, upon the entity's liquidation or dissolution, all of its assets be distributed to an entity that is a foreign government, an integral part of a foreign government, a controlled entity of a foreign government, or another organization that is described in this part or escheats to the government of the entity's country of residence or any political subdivision thereof.

Part XXIII Publicly Traded NFFE or NFFE Affiliate of a Publicly Traded Corporation

Check box 37a or 37b, whichever applies.

- 37a I certify that:
- The entity identified in Part I is a foreign corporation that is not a financial institution; and
 - The stock of such corporation is regularly traded on one or more established securities markets, including _____ (name one securities exchange upon which the stock is regularly traded).
- b I certify that:
- The entity identified in Part I is a foreign corporation that is not a financial institution;
 - The entity identified in Part I is a member of the same expanded affiliated group as an entity the stock of which is regularly traded on an established securities market;
 - The name of the entity, the stock of which is regularly traded on an established securities market, is _____; and
 - The name of the securities market on which the stock is regularly traded is _____.

Part XXIV Excepted Territory NFFE

- 38 I certify that:
- The entity identified in Part I is an entity that is organized in a possession of the United States;
 - The entity identified in Part I:
 - (i) Does not accept deposits in the ordinary course of a banking or similar business;
 - (ii) Does not hold, as a substantial portion of its business, financial assets for the account of others; or
 - (iii) Is not an insurance company (or the holding company of an insurance company) that issues or is obligated to make payments with respect to a financial account; and
 - All of the owners of the entity identified in Part I are bona fide residents of the possession in which the NFFE is organized or incorporated.

Part XXV Active NFFE

- 39 I certify that:
- The entity identified in Part I is a foreign entity that is not a financial institution;
 - Less than 50% of such entity's gross income for the preceding calendar year is passive income; and
 - Less than 50% of the assets held by such entity are assets that produce or are held for the production of passive income (calculated as a weighted average of the percentage of passive assets measured quarterly) (see instructions for the definition of passive income).

Part XXVI Passive NFFE

- 40a I certify that the entity identified in Part I is a foreign entity that is not a financial institution (other than an investment entity organized in a possession of the United States) and is not certifying its status as a publicly traded NFFE (or affiliate), excepted territory NFFE, active NFFE, direct reporting NFFE, or sponsored direct reporting NFFE.

Check box 40b or 40c, whichever applies.

- b I further certify that the entity identified in Part I has no substantial U.S. owners (or, if applicable, no controlling U.S. persons); or
- c I further certify that the entity identified in Part I has provided the name, address, and TIN of each substantial U.S. owner (or, if applicable, controlling U.S. person) of the NFFE in Part XXIX.



W-8BEN-E (Part III line 15):

: Sale of equipment, training, inspection, repairs, transport and sale of parts.

The taxpayer is a resident of Canada under the Canada-US Tax Treaty ("Treaty"). The taxpayer does not earn business profits attributable to a permanent establishment in the US pursuant to Articles VII and V of the Treaty and as such is not subject to US Federal income tax.

Stageline Mobile Stage Inc.

700 Marsolais, L'Assomption, Quebec, Canada J5W 2G9 • Tel: 450-589-1063 • 1-800-26-stage (North America) • Fax 450-589-1711
Web: <http://www.stageline.com> • E-mail: info@stageline.com



TRAINING PROGRAM



YOUR STAGELINE EQUIPMENT INTEGRATES FOUR PRODUCTS IN ONE

- A road legal trailer
- A heavy-duty hydraulic equipment
- A pre-assembled building structure
- A staging structure

UNDERLYING THIS PRODUCT ARE NO FEWER THAN FOUR TECHNOLOGIES

- Transportation
- Hydraulics
- Structural & Mechanical Engineering
- Scenic Technology



A series of operations effectively transforms the trailer into a stage that integrates all the scenic elements needed for rigging such as video wall, lighting equipment, sound system, windwall and banner installation. The key to it all lies in an integration so finely tuned that every component interacts perfectly with each other.

Technicians must therefore obtain a certain degree of technical knowledge to operate a Stageline equipment. Driven by the need to ensure technical efficiency, Stageline developed a training and certification program which meets and even exceeds its clients' and users' requirements.

Operation of a Stageline mobile stage by qualified personnel is directly linked with the enforceability of the warranty and the benefit of the 24/7 technical support offered to all Stageline certified technicians.

OBJECTIVES

With its training program, Stageline helps its users and clients increase profitability on their investment through an efficient utilization of the products.

Our experienced instructors offer practical and realistic guidance needed to optimize the participants' performance. Our main objective is to develop the aptitudes and technical knowledge of the manpower responsible for the operation of the unit in order to preserve the product's integrity and guarantee maximum safety levels.

CONTENT

The participants will learn to:

- Understand basic theoretical concepts and stage utilization steps;
- Understand specific interactions of all elements during operation;
- Recognize the risks and consequences of inappropriate use and operation;
- Lead and communicate efficiently with helpers or other technicians on a site;
- Act responsibly for all aspects of work with the unit so as to prevent any undesirable situation.

The operator's training program will include:

- Definitions, concepts and technologies involved in a Stageline mobile stage;
- Explanation of the Operator's Manual and of the set-up/dismantle sequences;
- Use of the trailer, including loading and efficient leveling methods;
- Set-up and dismantling of the stage;
- Tools and practical techniques for solving mechanical and hydraulic problems;
- Notions and critical factors for scenographic use and application of load limitations.

EDUCATION METHODOLOGY

- Workshop and practical exercises
- Demonstration and simulation of critical situations (group and individual);
- Attendance and practical examination (practical examination must be successfully passed to obtain certification);
- Attendance throughout the session;
- Understanding of the theoretical aspects of the stage;
- Certification is based on the trainee's understanding of the product's integrity and safety in general.

PARTICIPATION AND EVALUATION MODE

- In-field practical exercises completed by theoretical training;
- User's Manual;
- The Operator Training Course includes a practical and formal evaluation of each and all participants.

DURATION

3 to 7 days depending on stage model.

NUMBER OF PARTICIPANTS

Group limited to four (4) people (per instructor/per stage).

SKILLS & ASSETS

1. Leadership.
2. Manual dexterity and general technical knowledge.
3. Experience in show-business (scenography), or outdoor events.
4. Knowledge of mechanics and hydraulics.
5. Knowledge or experience in the trucking industry.

CONDITIONS

1. The certificate issued in the technician's name is not transferable and remains valid as long as the technician is still active with the operation of the stage.
2. Certificates are issued solely by Stageline which reserves the right, at all times, to revoke the certification of any technician if major neglect or mistakes are committed.
3. Certified technicians unable to report a minimum pertinent practical operation of the Stageline product in the current year could have their status reexamined. The certification exam might be needed to maintain the validity of the certificate.
4. The technician must hold a written record of the set-ups/dismantles accomplished.
5. Stageline does not guarantee the participants' success. The instructor may refuse any participant if major negligence or mistakes have been detected which may compromise the group's safety or the product's integrity.

LOCATION

OPTION 1

Training courses are given at the client's chosen location for a specific group.

Instructor's expenses: all related costs, such as hotel, transportation and other expenses will be charged to the client. The following will be required throughout the training course:

- The Stageline equipment;
- Availability of a truck and driver;
- Stagehands;
- An adequate site: accessibility, sufficient space and 24-hour security;
- Classroom and equipment.

OPTION 2

Training courses can be given at Stageline's facilities in L'Assomption, Quebec, for a specific group or individuals. Trainee's expenditures: all related costs, such as hotel, transport and other expenses will be the client's responsibility. Stageline will provide the stage throughout the training course.





INSPECTION PROGRAM



Like any sophisticated piece of equipment, the Stageline mobile stage requires basic maintenance throughout the year. This maintenance must be performed according to specific guidelines.

"The mobile stage must be inspected within the last 24 months by a competent authority for this certificate to be valid. If critical defects are found on the structure during the inspection, repairs and procedures must be approved by a structural engineer and completed according to professional standards."

YOUR STAGELINE EQUIPMENT INTEGRATES FOUR PRODUCTS IN ONE

- A road legal trailer
- A heavy-duty hydraulic equipment
- A pre-assembled building structure
- A staging structure

UNDERLYING THIS PRODUCT ARE NO FEWER THAN FOUR TECHNOLOGIES

- Transportation
- Hydraulics
- Structural & Mechanical Engineering
- Scenic Technology

The key to making sure that the staging system functions perfectly lies in an integration so finely tuned that every component interacts perfectly with each other. With this in mind, Stageline's engineers and experienced technicians have developed a unique inspection program. This program will give you a complete analysis of your equipment's condition including a list of immediate repairs and recommendations.

Each mandated Stageline inspector is a Stageline product specialist and knows all technological aspects of Stageline equipment as well as the various common applications of our products.

METHODS

- Visual inspection and functional testing;
- Verbal preliminary report;
- Point-by-point verification list ;
- Written report.

INSPECTION POINTS

- Hydraulic components;
- Structural components;
- Mechanical components;
- Stage structure;
- Efficient operation of all systems;
- Aesthetic and degree of wear and tear. [Soft goods are not included i.e. windwalls and skirts.]

FINAL PRODUCT

- Detailed Technical Inspection Report including technical recommendations;
- On site maintenance suggestions;
- Estimate (if applicable);
- The service department will support you in any action following the inspection.

CONDITIONS

- The stage and a manageable site must be available;
- The owner or one of his/her representatives must be present and available at the inspector's request;
- One or more stagehands are to be provided for the duration of the inspection process.

TO REACH STAGELINE SERVICE DEPARTMENT

Toll free (Can./US only): 1 800 267-8243

Telephone: +1 450 589-1063

Fax: +1 450 589-1711

customer@stageline.com

www.stageline.com



**TECHNICAL
SUPPORT
24/7!**

**(FOR CERTIFIED
TECHNICIANS)**



ECO-CONSCIOUS

COMPANY

ALL OUR PRODUCTS ARE MANUFACTURED IN A LEED CERTIFIED , GREEN PRODUCTION FACILITY INTEGRATING THE LATEST ENVIRONMENTAL TECHNOLOGIES

- Stageline stages are made of recycled steel (+/- 73%)
- Recyclability of a mobile stage: 80%
- Proven durability of the equipment exceeding 25 years

STAGELINE MOBILE HYDRAULIC STAGES SIGNIFICANTLY REDUCE THE IMPACT OF OUTDOOR EVENTS ON THE ENVIRONMENT

- No cranes, boom trucks or forklifts required for deployment: the unit is self-contained, self-deployable and offers ample cargo capacity
- Only one truck/tractor is needed to move the equipment
- No ground preparation needed before the event: no grading or anchoring needed

SETTING THE STAGE FOR A GREENER FUTURE !



MOBILE STAGES
REAL LIFE TRANSFORMERS



STAGELINE.COM



February 18th, 2022

Chris Baird – Strategic Development Director
Grand County Commission Administrator's Office
125 East Center Street
Moab, UT 84532

Dear Chris,

REF: Invitation to Bid - 24' x 20' Mobile Stage

Thank you for giving Stageline the opportunity to submit our comprehensive proposal and pricing for the **Stageline SL100** (24' x 20') mobile stage for Grand County.

Our proposal for the **Stageline SL100** meets the specifications exactly outlined in your bid document

The **Stageline SL100** gives you flexibility and scope in the types of events that it can be used, for small shows to full scale concerts with height, rigging and visibility.

Stageline Mobile Stage inc., established in 1987 is the pioneer and world's leading designer and manufacturer of innovative mobile stages and promotional units.

Our commitment has always been to provide a safe staging environment to fellow workers, musicians, organizers, and audiences. Stageline mobile stages are now used on over 20,000 events every year in more than 50 countries. Our mobile stages have proven to remain safe while protecting gear and people throughout the most extreme weather conditions.

Many cities and municipalities throughout North America will attest that no other staging product can measure up to the efficiencies provided by Stageline technology.

With its unique design combining 4 technologies and patented telescopic lifting mechanisms, the **Stageline SL100** is the most advanced mobile staging system of its size available in North America.

Stageline Mobile Stage Inc.

700 Marsolais Steet, L'Assomption, QC, J5W 2G9 • Tel: 450-589-1063 • 1-800-26-stage (North America) • Fax 450-589-1711
Web: <http://www.stageline.com> • E-mail: info@stageline.com



We are very proud to have been rewarded with several industry awards in recent years including Staging Company of the Year and Stage of the Year at the prestigious Parnelli Awards.

Important points to consider:

- Stageline mobile stages are the **ONLY** products to be designed to the latest IBC Codes
- Stageline has \$20,000,000 coverage on liability and manufacturer's defaults
- Stageline offers a 24-hour service line operated at no cost to the client
- Design briefs supporting all design and engineering data are continuously issued and immediately available
- Stageline equipment is built to last 30 years when properly maintained and operated and retains 70% of its value after 5 years.

We trust you will agree that the **Stageline SL100** can provide your community with the most versatile, efficient and safe mobile staging solutions available.

Kind regards,

A handwritten signature in blue ink that reads "T. Beresford".

Tony Beresford
Stageline Mobile Stage inc.

SL100

THE SL100
IN A CLASS OF ITS OWN

STAGE
LINE

Photo: Scott Thompson / StageRental.com





STAGELINE ADVANTAGES

STAGELINE, THE SPECIALISTS FOR OVER 35 YEARS IN DESIGNING, PRODUCING AND DELIVERING THE SAFEST AND MOST INNOVATIVE MOBILE STAGES TO OUTDOOR EVENTS.

- Most requested mobile stage in its category
- Holds the market lead in rigging & wind resistance
- Built to last 25 years and more
- Outstanding payback and great resale value

SL100

JOHN DEERE
GOLF

Photo: Scott Thompson / StageRental.com



IT ALL STARTS ON THE ROAD

STAGELINE MOBILE STAGES ARE ENGINEERED FOR THE ROAD.

Before its main usage as an outdoor stage, a mobile stage must perform as a road legal trailer.

Stageline advanced design combines a custom chassis with multiple hinged panels and telescoping structures that will not alter in performance from mileage and bad roads. It results in excellent road handling and safety year after year.

HAULING OPTIONS

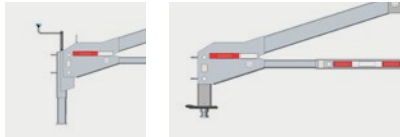

Gooseneck or king pin

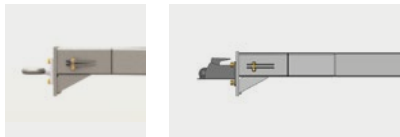

Drawbar for pintle hook or ball hitch





A HIGH PERFORMANCE STAGE

WITH A COMPLETE HYDRAULIC SET UP

- Fast and controlled operations
- Precision designed cylinders with safety block valves
- Low maintenance

1



Position & level the trailer.

2



Hydraulically deploy the floor and roof panels.

3



Hang sound, lighting, banners, windwalls and sets from ground and deck level.

4



Raise the roof with up to 3,800 lbs (1,725 kg) of show equipment.

Install stairs, guardrails and add accessories.

AT A GLANCE



FLOOR

24' x 20' (7 m x 6 m)
up to 40' x 28' (12 m x 8 m)
with extension platforms

SET-UP



2 technicians*



30 minutes

WIND RESISTANCE

115 mph (185 km/h)
without windwalls

77 mph (123 km/h) with windwalls

RIGGING

11,400 lb (5,190 kg)

6' outriggers on each side /
1,500 lb (680kg) per side

* Stageline promotes safe working habits by having a minimum of two workers on every job site.

SHOWCASE YOUR SPONSORS & EVENTS

On the road trailer wrap advertising panels

24' x 7' (7 m X 2 m) - rivet-free panels with gel coating that improve graphics application and appearance.

MAXIMUM BANNER SPACE

- 1 Top banner 37' x 4' (11 m x 1.2 m)
- 2 2 Side banners 6' x 16' (1.8 m x 5 m)
- 3 Backdrop 23' x 13' (7.1 m x 4 m)
- 4 Skirt 40' x 4' (12.2 m x 1.4 m)

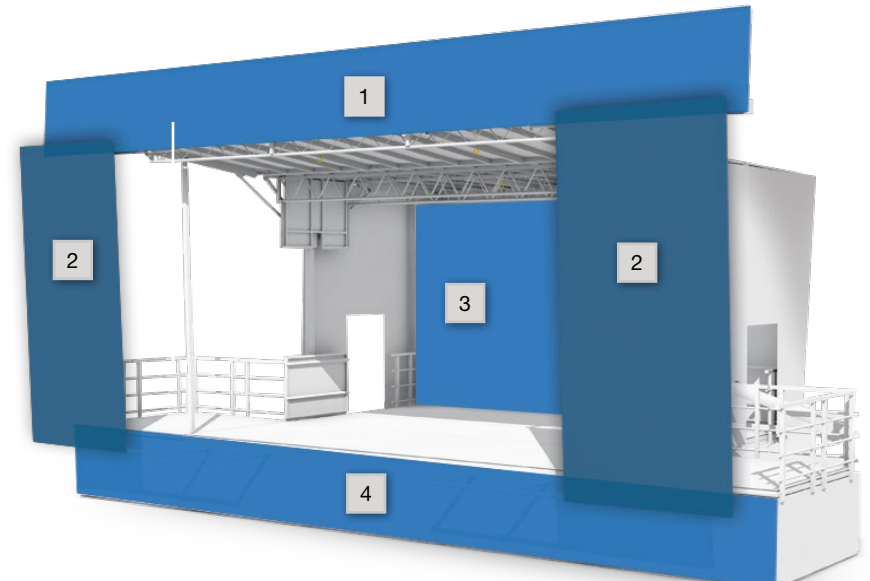

Lake Wales High School

LW
YOU
ARE YOUR
BROTHER'S
KEEPER

LW
YOU
ARE YOUR
BROTHER'S
KEEPER

LW
YOU
ARE YOUR
BROTHER'S
KEEPER

SAFE & EFFICIENT INSTALLATION

WORK FROM GROUND & DECK LEVEL

All the work and installation of sound, light, banner is done from deck and ground level reducing the risk of climbing accidents.

3,800 LB (1,725 KG) OF HYDRAULIC LIFTING CAPACITY

TOTALLY SELF STANDING

No ballast or cables required

SUPERIOR DESIGN FOR LOADS & RIGGING

The SL100 is designed, built and tested with the highest load and rigging design criteria in the industry – up to 2 times the permitted load.





Deck & chassis at 150 lb/ft² (732 kg/m²) meets IBC & NBC standards
Cross braced steel members added to support legs under the mid-section of trailer frame.



Storage
Custom underfloor storage system for staging components.



Storage
Corner posts stored in roof panels. Easy to access.



Raise & lower the roof securely with double mast lifting mechanism

A set of sturdy masts lifts and lowers the roof and show support equipment. They function with balanced or unbalanced loads even in difficult weather conditions.



Lights

4 battery powered LED work lights.
2 in the roof – 2 under the floor.



Battery

Battery system for work lights, emergency breakaway system and engine starter.

MORE RIGGING POSSIBILITIES TO PLAY WITH

Multiple rigging options

- 1 24 built in rigging points with a capacity of up to 1,500 lb (680 kg).

Movable rigging brackets

- 2 4 movable rigging brackets provided.

Front overhang pipes

- 3 Capacity of 700 lb (317 kg) at 2'-9" (0.84 m) from roof edge – 9' 4" (2.85 m) rigging pipe.

T2 Trusses

- 4 Strong capacity of 1,200 lb (544 kg).



1

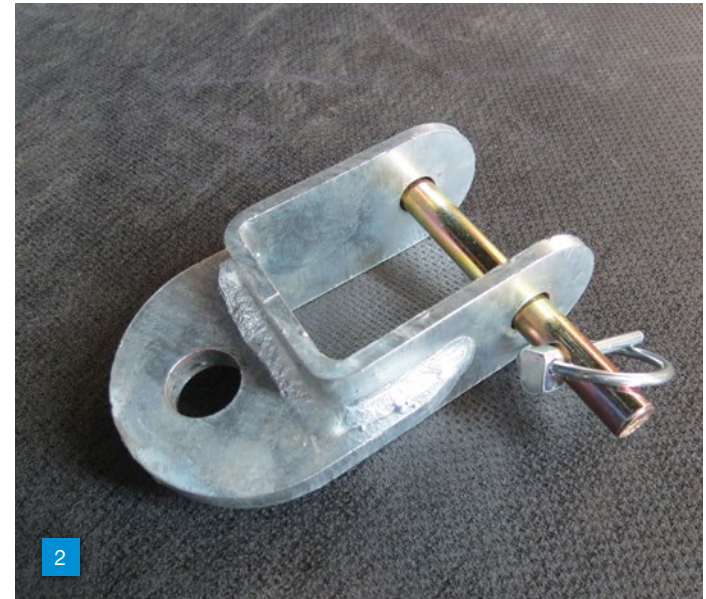

2



Photo: Upstage Crew Services

6' SIDE RIGGING TRUSS

Standard Flybay

1,500 lb (680 kg) capacity per side.

1 Truss deploys in seconds.

Optional Flybay

2 Line array and screen rigging capability with multiple configurations.

Rigging points for PA

3 In front of all 4 corner posts. PA extension bars available.*

* Image in blue is a representation of the actual PA extension beam.

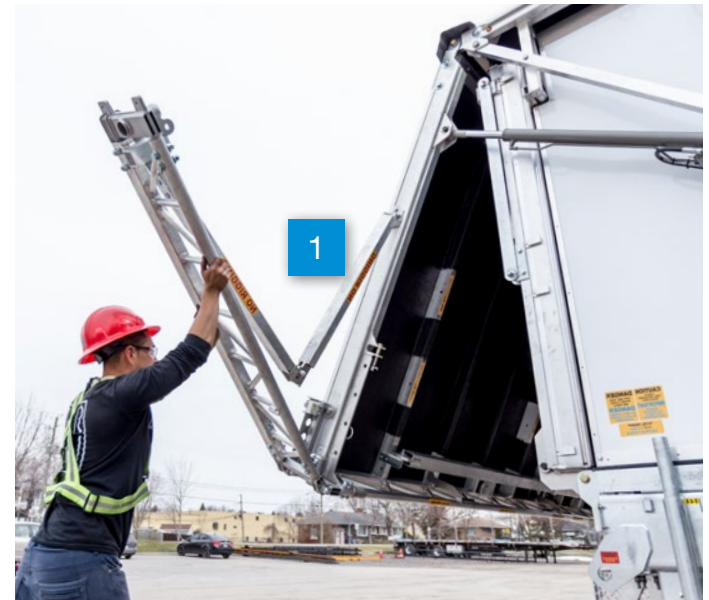

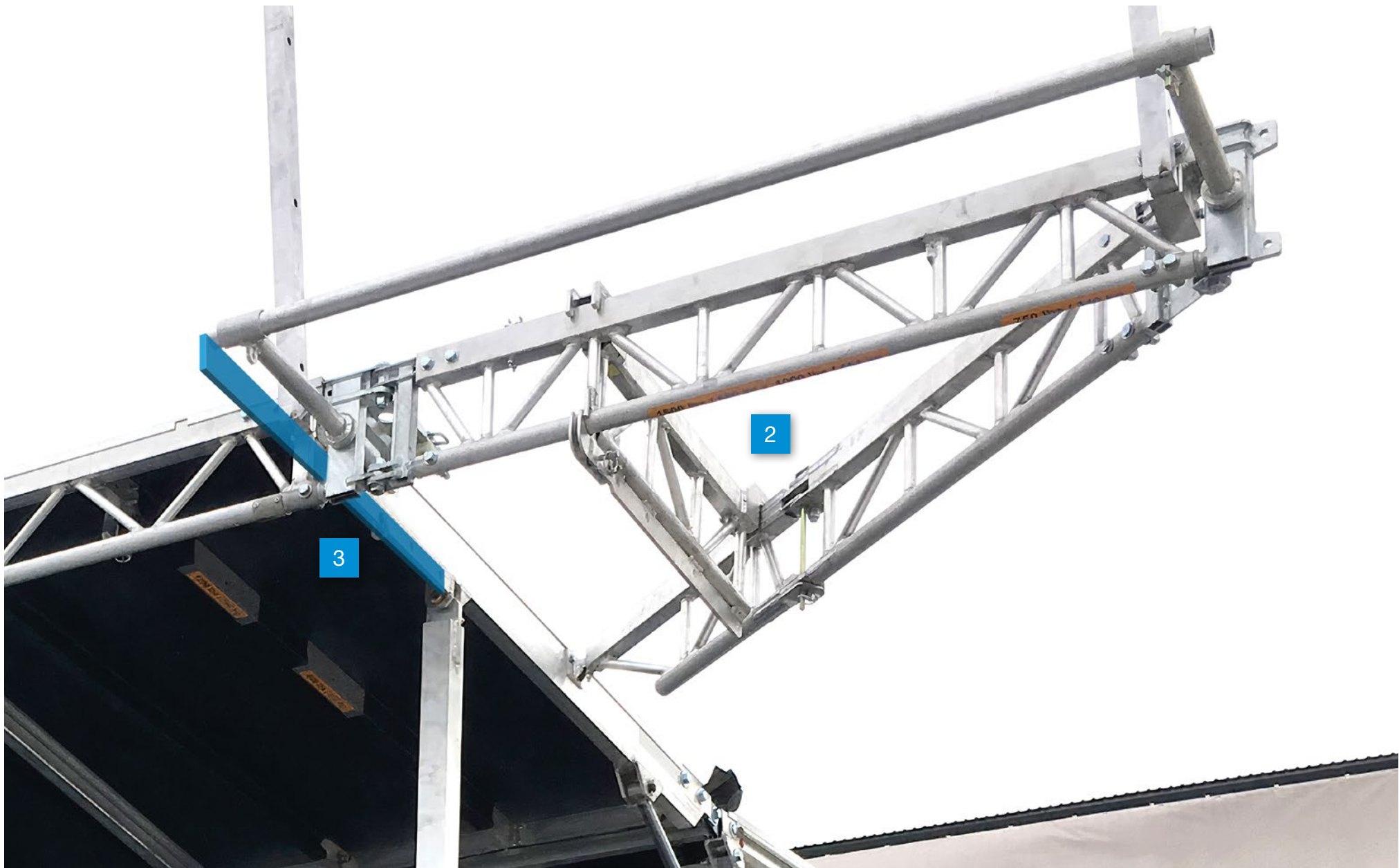

SCREENS

**1,500 LB (680 KG) CAPACITY PER SIDE.
INCREASED RIGGING OPTIONS WITH THE
6' (1.8M) SIDE RIGGING TRUSSES FOR
LED SCREEN OR SPEAKERS.**

**1 LINE ARRAY CAPABILITY FREE UP
FLYBAY FOR VIDEO WALL.**





SAFETY AND RELIABILITY IN ALL CONDITIONS

HIGHEST WIND RESISTANCE IN THE INDUSTRY

Rain and wind protection up to:

- **115 mph (185 km/h)** without windwalls
- **77 mph (123 km/h)** with PVC windwalls

Rain or shine, sand or snow

Stageline mobile stages are built to be operated under the most demanding outdoor conditions.

The SL100 is engineered and built based on the IBC (International building code) & NBC (National building code)

Exceeds AINSI standards



Photo: AV Strategies

MAXIMUM WEATHER PROTECTION

A STAGE DESIGNED TO MANAGE WINDY CONDITIONS

Sturdy windwalls

- 1 Fire retardant vinyl windwalls with a keeper track system preventing water infiltration to protect gear, talent and crew.

Protection on and off the road with a roof made of fiber glass.

- 2 In closed position, the roof panels of the stage become the side panels of a hardshell trailer. Wrapped around the frame they are structural and weather protective.*

* Blue in picture to highlight keeper track system and Fiber Lock wrap.



**WE JUST TOOK 75 MPH (120KM/H) WINDS, GOLF BALL SIZE HAIL AND
4 INCHES OF RAIN IN 30 MINUTES AND THE ENTIRE EVENT SPACE
IS DEVASTATED WITH TENTS BROKEN EVERYWHERE.**

**THE ONLY THING I'M NOT HAVING TO DEAL WITH RIGHT NOW, IS AN
ABSOLUTELY PRISTINE SL100 STANDING PROUD IN THE MIDDLE OF IT.**

– Jeff Krebs, Epicenter Productions



WHY THE INDUSTRY PREFERS STAGELINE

Most Widely used

More than 25,000 events per year in over 50 countries - an average of 68 events per day.

Craftsmanship and expertise

Every stage is built in-house and benefits from serious engineering and craftsmanship with experience gathered from decades of use in outdoor events.

Quality control and delivery

Each mobile stage goes through a complete inspection during manufacturing including load tests and complete installation prior to delivery.

Exceptional durability and reliability

Built to last 25 years and more with proper care and maintenance.

Provider of safe staging environments for over 30 years

Highest wind resistance - up to 115 mph (185 km/h) without windwalls and 77 mph (123 km/h) with windwalls. No incident causing an injury due to a breakdown of equipment.

Outstanding value

Low operation and maintenance cost. High resale value even after 10 years.

Certification

Each stage complies with road regulations. Stageline provides complete engineering certification for both structural design and rigging capacity for all countries. Certified documents available for each state and province of the US and Canada.

Environmentally responsible

All products are manufactured in Stageline's state of the art LEED® certified facility integrating the latest environmental technologies.

Award-winning

Our company and products have achieved high acclaim in the industry and have won several engineering and event industry awards.



CUSTOMER SERVICE

Customer Support

We provide a complete 24/7 after sales support.

Parts & Accessories

The best way to ensure that your Stageline mobile stage retains its original condition is to purchase your parts and accessories directly from Stageline.

Inspection & Maintenance

Like any sophisticated piece of equipment, a Stageline mobile stage requires basic maintenance throughout the year. This maintenance must be performed according to specific guidelines.

With this in mind, Stageline's engineers and experienced technicians have developed a unique inspection program. This program will give you a complete analysis of the condition of your equipment including a list of immediate repairs & recommendations.



Training

Driven by the need to ensure technical efficiency, Stageline developed a training and certification program which meets and even exceeds its clients' and users' requirements. Operation of a Stageline mobile stage by qualified personnel is directly linked with the enforceability of the warranty and is required to benefit from the technical support offered on all Stageline products.

With its training program, Stageline helps its users and clients increase profitability on their investment through an efficient utilization of the products.

The main goal is to develop the aptitudes and technical knowledge of the technicians in order to preserve the products' integrity and guarantee durability and maximum safety levels.

UNMATCHED ADDED VALUE

A STAGE THAT PAYS FOR ITSELF FOR GOOD REASONS:

Built to last over 20 years, this stage will help you maximize your benefits for years while endorsing a strong commitment to sustainability.

THIS STAGE COMES WITH THE HIGHEST RESIDUAL VALUE OF ANY MOBILE STAGE

It retains 50-75% of its value after 10 years

OFFERS A STRONG LEVERAGE ON YOUR OTHER SERVICES AND A QUICK RETURN ON INVESTMENT

STAGE CARE WARRANTY (TRANSFERABLE)

We are so confident in our staging technology that we offer the Stage Care Warranty that conveys a lasting assurance equal to none

- Full 1 year parts and labor
- 3 years on the chassis and structure
- 5 years on the fiber glass

MEET THOSE WHO OWN

DURABILITY AND VALUE

“Each year I flirt with the idea of purchasing more Stageline equipment. All I can tell you is that used, properly maintained Stageline equipment sells quickly. I watch the secondary market out of habit and its very rare to find anything, plus it usually maintains almost all of its dollar value as new.”

**Dolph Federico /
Pelican Events, New Orleans, LA**

PRODUCTION AND ENTERTAINMENT

“SL100 is defacto a standard in the industry. Everyone of professional note use Stageline. I wanted that bulletproof proven technology, workmanship, and engineering. Stageline’s SL100 changed my life!”

**Laurence Sheldon /
Big Ear Audio, CA**

MUNICIPALITIES / PARKS AND RECREATION

“The “Rec & Roll Stage” is a hit in our community! The size and versatility of the SL100 combined with the ease of set-up make it perfect for our needs. We’ve used it for performances, graduations, and speeches. Community requests keep coming in and we’re the envy of our neighboring communities.”

**Ron Rodriguez /
Recreation Services Manager /
Recreation and Parks Department,
City of Santa Maria, CA**

TECHNICAL SPECIFICATIONS

NOTABLE BENEFITS

Site Preparation

None

Mode of Transportation

1 Pick-up truck or hauling vehicle

Wind Resistance

115 mph (185 km/h) without windwalls or
77 mph (123 km/h) with windwalls

Promotional Visibility

Rolling billboard or banners and posters

Backdrop*

Weatherproof - fire retardant vinyl or scrim

Vertical and Horizontal Banner Supports*

Installed at ground level

TRAILER		
Length	31' 9"	9.69 m
Width	8' 0"	2.43 m
Height	11' 2"	3.40 m
Dry Weight	9,460 lb	4,290 kg
Maximum Weight	15,000 lb	6,804 kg
STAGE FLOOR		
Length and Depth	24' x 20' 1"	7.32 x 6.1 m
Height	3' 6" to 4' 3"	1.07 x 1.30 m
Design Live Load	150 lb/ft ²	732 kg/m ²
Type of Surface	Plywood on aluminium	
ROOF		
Length and Depth	25' 1" x 23' 9"	7.64 x 7.23 m
Clearance (Inclined roof)	14' 6" to 13' 2"	4.43 to 4 m
Height (from ground)	19' 0" to 19' 9"	5.79 to 6.02 m
Type of Surface	Fiberglass moulded around aluminum structure	
Roof Lifting Capacity	3,800 lb	1,725 kg
Roof Load Bearing Capacity	2,400 lb	5,190 kg
2 Trusses - Downstage & Upstage (T2)	1,200 lb (each)	544 kg (each)
2 Trusses - Central Roof (T1)	1,500 lb (each)	680 kg (each)
2 Front Overhang Extensions*	350 lb at 33" each	159 kg at 0.84 m each
2 Side Overhang Rigging Beams	1500 lb (each) 750 lb at 75" each	680 kg (each) 340 kg at 1.89 m each

† Please refer to rigging plan.

* Optional

Values indicated are nominal. Due to STAGELINE'S product improvement policy, technical specifications may change without notice.



Standard 24' x 20' (7m x 6m)

SOME FLOOR CONFIGURATIONS

FROM A BANDSHELL TO A FULL PERFORMANCE STAGE CONFIGURATIONS

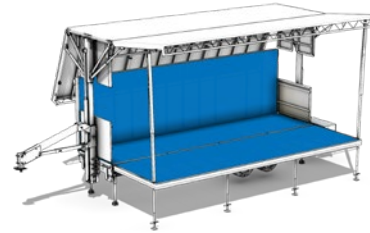

Bandshell 24'x13'
(7m x 4m)

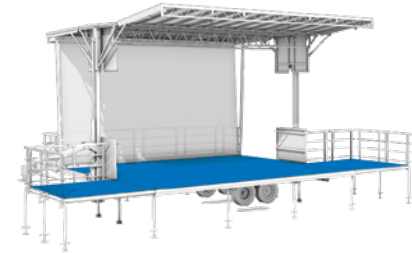

Standard 24'x20' (7m x 6m)
with 8'x8' (2.5m x 2.5m)
sound wings

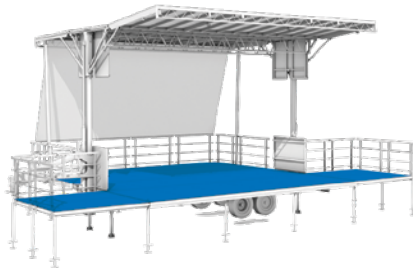

Back Extended 4'x24' (1m x 7m)
with 8'x8' (2.5m x 2.5m)
sound wings

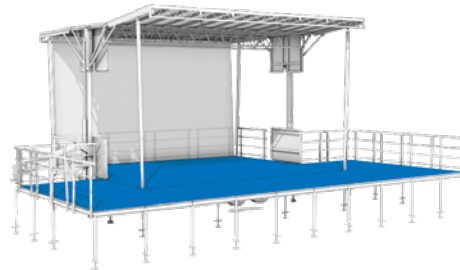

Standard 24'x20' (7m x 6m) with
8'x8' (2.5m x 2.5m) sound wings and
8'x40' (2.5m x 12m) at the front

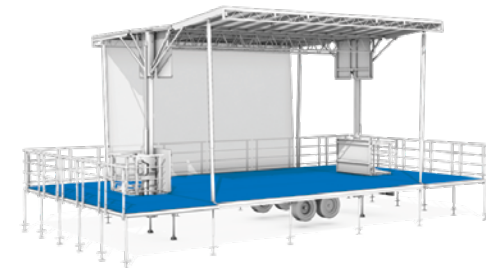

Standard 24'x20' (7m x 6m)
with 12'x20' (3.5 x 6m) sound wings

827 L'Ange-Gardien Blvd., L'Assomption
Quebec, Canada J5W 1T3
1 450.589.1063 / North America 1 800.267.8243
stageline.com

MOBILE STAGES | SALES & RENTALS



PURCHASE AND SALES AGREEMENT

This Purchase and Sales Agreement (the "**Agreement**") is entered into effective as of _____, by and between **Stageline Mobile Stage Inc.** ("**Seller**") and _____ ("**Buyer**").

WHEREAS Seller designs and manufactures mobile stages;

WHEREAS Buyer wishes to purchase a mobile stage from Seller, which wishes to sell a mobile stage to Buyer, the whole subject to the terms and conditions hereinafter detailed;

NOW, THEREFORE, SELLER AND BUYER AGREE AS FOLLOWS:

1. **Preamble.** The Preamble hereof forms an integral part of this Agreement as if herein recited at length in full.

2. **Purchase of Stage.** Buyer agrees to buy from Seller, which agrees to sell to Buyer, the mobile stage, additions, attachments and accessories described in the Sales Quote and or Purchase Order, attached hereto in Annex A, (collectively the "**Stage**"), the whole subject to the terms and conditions hereinafter detailed.

3. **Purchase Price.** The price (the "**Price**") to be paid under this Agreement and the payment terms are clearly detailed on the Invoice, attached hereto in Annex B. Buyer's obligation to pay the Price in full and all other amounts payable to Seller hereunder shall be absolute and unconditional. Buyer shall be solely responsible for the payment of all taxes, licenses, tariffs, registration fees, permits and all other fees and assessments in connection with Buyer's purchase, ownership, transportation, training and use of the Stage.

4. **Terms and Condition of Sale.** The sale of the Stage will be subject to all of the provisions of this Agreement. If there are any inconsistencies between this Agreement, on the one hand, and any terms and conditions of Buyer, on the other, including without limitation terms and conditions on Buyer's purchase orders, this Agreement shall govern.

5. **Delivery.** Subject to payment in full of the Price, pick up of the Stage will be on a date mutually agreed between Seller and Buyer, E.X.W. Seller's factory or warehouse located in the city of L'Assomption, Quebec, Canada. At the request of the Buyer, Stageline will make the necessary arrangements for the transportation of the stage to the location agreed upon, as well as cargo insurance on behalf of the Buyer. Buyer shall be responsible for the payment of all freight, transportation, insurance, shipping, storage, handling, demurrage or similar charges. Risk of loss or damage to the Stage shall pass to Buyer upon delivery of the Stage by Seller.

6. **Title.** Title to the Stage shall pass to Buyer upon payment in full of the Price and execution of this Agreement by Buyer.

7. **Limited Warranty.** Seller represents and warrants that the Stage will be free from material defects in workmanship and labor for a period of one (1) year from the date of delivery. Seller shall be solely responsible for the cost of all warranty parts and labor. No warranty is given by Seller with respect to fabrics, tires or rubber roof seals. **If there is a manufactured flaw with the rubber seals, Seller will cover this in the first year of ownership (subject to paragraph 8 below).** The warranty does not cover transportation charges and expenses for the Stage or any person, including the employees of Seller and Buyer, nor does the warranty cover hotel accommodation and related expenses. The express warranties set forth in this Agreement are the only warranties with respect to the stage, and the remedies set forth herein are buyer's exclusive remedies in the event of a breach of such warranties. Seller hereby disclaims all express and implied warranties that are not specifically contained in this Agreement, including without limitation the implied warranties of merchantability and fitness for a particular purpose. Seller shall not be liable for any incidental or consequential damages or any nature resulting, directly or indirectly, from any breach of such warranties, either before or after the delivery of the stage.

8. **Warranty Repair.** Buyer shall give Seller an immediate detailed written report (with photographs, drawings and depictions) by email of any mechanical breakdown or problem with the Stage, whether or not the mechanical breakdown or other problem is covered by Seller's limited warranty. If the problem is covered by Seller's limited warranty, Seller will attempt to assist Buyer's technician by email or telephone to resolve the problem. If Buyer and Seller are unable to resolve the warranty problem in this manner, as soon as reasonably practicable, Seller, in its sole discretion, will either: (a) send its own technician to the site of the Stage to perform warranty repairs, or (b) give Buyer written authorization to have the Stage repaired by a third party.

9. **Seller's Confidential Information.** Buyer represents, warrants and agrees that Buyer and Buyer's owners, shareholders, directors, officers, employees, agents, representatives, attorneys, affiliates, predecessors and successors ("**Related Persons**") will keep confidential the features of any equipment, patterns, designs, drawings, production or engineering data, or other technical, confidential or proprietary information related in any way to the Stage which may be provided by Seller to Buyer or any of its Related Persons from time to time. All such confidential and proprietary information will be used by Buyer and its Related Persons only for the purpose of utilizing the Stage purchased by Buyer hereunder. At no time will Buyer or any of its Related Persons disclose such confidential or proprietary information to third parties, or use such confidential or proprietary information for any purpose other than utilizing the Stage purchased hereunder, without Seller's prior written consent.

Upon written request from Seller from time to time, Buyer and its Related Persons will return to Seller all such confidential and proprietary information, and copies thereof, or dispose thereof as Seller directs.

10. **Modifications and Improvements.** In the event of any modification or improvement by Seller in respect of the Stage, Seller, in its sole discretion, may provide Buyer with technical or instructional bulletins ("**Bulletins**") from time to time. Buyer hereby agrees to comply with all Bulletins. The cost of compliance with the Bulletins shall be Seller's sole responsibility in the event the Bulletins pertain to safety factors or Buyer's sole responsibility in the event the Bulletins pertain to the installation, operation or maintenance of the Stage. If Buyer fails for any reason to comply with any Bulletins pertaining to safety factors, then, all

warranties set forth in this Agreement in respect of the Stage shall be deemed *ipso facto* null and void and of no further force or effect.

11. **Training.** Seller has developed a specific training program for the equipment purchased and warrants the availability of a specialized technician (hereinafter the "Trainer") to convey the training. As a condition precedent to the enforceability of the limited warranties provided in this Agreement, before using the Stage, and continuing at all times during the warranty period on the Stage, Buyer will ensure that at least two (2) of its technicians (hereinafter the "Qualified Persons") have been trained and certified by Seller to operate and use the Stage and that the Qualified Persons have all appropriate permits and licenses to operate and use the Stage, and that the Stage will be used exclusively by or under the direct supervision of Qualified Persons. All training of Buyer's technicians shall be at Buyer's sole cost, either at Seller's facility or at another location acceptable to Seller. Buyer shall be solely responsible for all expenses of the trainer and of the technicians in training. In addition, for training that takes place away from Seller's facility, Buyer shall pay all expenses of Seller's instructors, including without limitation flat daily rate for voyaging salary, travel, per diem, hotel and ground transportation.

12. **Inspection and Maintenance Policy.** Buyer acknowledges that the Stage is comprised of two (2) principal structures; namely: (a) the trailer (the "Trailer"), which includes, without limitation, the steel or aluminum frame upon which the Stage is manufactured, the motor that operates the lifting system, the suspension system, the axles, the braking system and the tires; and (b) all other aspects of the Stage (the "Functional Structure"). Buyer agrees, represents and warrants that it shall fully inspect and maintain the Stage on a timely and on-going basis, same to include, without limitation, the following:

(a) Buyer agrees, represents and warrants that it shall fully inspect and maintain the Trailer at least one (1) time per year, or more often if circumstances warrant, by fully qualified and licensed mechanics and in conformity with all laws that are applicable in the circumstances to such inspection and maintenance; and

(b) Buyer agrees, represents and warrants that it shall fully inspect and maintain the Functional Structure at least one (1) time per year or more often if circumstances warrant, in accordance with the specifications and standards that are established by Seller from time to time.

With regard to the foregoing inspections and maintenance, moreover, Buyer shall, on a timely basis, accurately complete and return to Seller all inspection and maintenance forms issued by Seller to Buyer.

Failure by Buyer to comply with any of the foregoing provisions shall *ipso facto* nullify and void the limited warranty granted to Buyer under this Agreement.

13. **Use of Stage.** Buyer acknowledges that the Stage comprises specialized and complex equipment, and that the transportation, installation, set-up, operation, use, de-installation and storage of the Stage require technicians with specialized knowledge and training. Buyer, therefore, hereby represents and warrants to Seller that at all times commencing from the delivery of the Stage to Buyer the Stage will be transported, installed, set up, operated, used, de-installed and stored in accordance with all requirements of Seller's most current operations manual (the "Operations Manual") exclusively by Qualified Persons.

14. **Alterations/Modifications Prohibited.** Buyer hereby represents and warrants to Seller that Buyer shall not under any circumstances whatsoever, unless it has received the prior express written authorization of Seller, alter and/or modify the Stage in any manner whatsoever, including, without limitation, alter and/or modify any part of the Stage that will affect or will likely affect the structural integrity of the Stage to the slightest degree.

15. **Nullification of Limited Warranty.** In addition to any other provision of this Agreement dealing with the same subject matter, in the event that any of the provisions of this Agreement entitled "Use of Stage" or "Alterations/Modifications Prohibited" or "Warranty Repair" are breached by Buyer, the Limited Warranty granted to Buyer under this Agreement shall *ipso facto* become null and void and without any further effect.

16. **Intellectual Property.** Seller is the exclusive owner of the «STAGELINE», «STAGEVAN», «SL Series», and «SAM Series» trademarks and all other trademarks, service marks, logos and trade names associated with Seller's products (collectively, "Marks"), all good will connected with the Marks, and all designs, patents, technology, know-how, copyrights, and other intellectual property related to the Stage (collectively, «**Intellectual Property**»). Buyer acknowledges and agrees that Buyer has no right, title or interest in or to the Marks or the Intellectual Property. Neither Buyer nor any of Buyer's Related Persons shall directly or indirectly do any of the following without the prior written consent of an authorized officer of Seller: (a) use the Marks or Intellectual Property; or (b) disclose the Marks or Intellectual Property to any third persons; or (c) copy the Marks or Intellectual Property; or (d) use any marks, technology or intellectual property that are confusingly similar to the Marks or the Intellectual Property; or (e) remove or modify Seller's Mark and logo on the Stage. Buyer shall provide photographs of the Stage to Seller in road and open positions, and shall permit Seller or its representative to photograph the Stage, and Buyer hereby grants to Seller an unconditional, irrevocable non-exclusive right and license to use photographs and depictions of the Stage for promotional purposes without any additional consideration or amounts payable to Buyer.

17. **Termination of Agreement.** Seller shall have the right to suspend its performance and terminate this Agreement immediately upon written notice to Buyer, if prior to payment in full of the Price, Buyer shall become insolvent or bankrupt, make a general assignment for the benefit of, or enter into any arrangement with, any creditor, or if a petition is filled in respect of Buyer under any bankruptcy, insolvency or similar law. Should Seller terminate this Agreement as aforesaid, (a) Seller shall be entitled to retain all amounts received from Buyer, with no obligation to return any portion of such amounts to Buyer; (b) Buyer shall immediately return the Stage to Seller; and (c) Buyer shall have no rights of any nature whatsoever in respect of the Stage.

If Buyer decides to terminate this agreement, Seller shall be entitled to retain all amounts received from Buyer, with no obligation to return any portion of such amounts to Buyer and Buyer shall have no rights of any nature whatsoever in respect of the Stage.

18. **Indemnification by Buyer.** Buyer agrees to indemnify, defend and hold harmless Seller, and Seller's shareholders, directors, officers, employees, agents and representatives, from and against any and all liabilities, losses, damages, injuries, costs, expenses, actions, claims, suits, demands, legal proceedings, assessments and similar matters, including without limitation reasonable attorneys' fees, resulting from or arising out of any failure by Buyer to fulfill any of its obligations under this Agreement, or any act or omission of Buyer or any of Buyer's agents or representatives in respect of the Stage.

19. **Indemnification by Seller.** Seller agrees to indemnify, defend and hold harmless Buyer, Buyer's principals, and their respective shareholders, directors, officers, employees, agents and representative from and against any and all liabilities, losses, damages, injuries, costs, expenses, actions, claims, suits, demands, legal proceeding, assessments and similar matters, including without limitation reasonable attorney's fee, resulting from or arising out of any failure by Seller to fulfill any of its obligations under this Agreement, or any act or omission of Seller or any of Seller agents or representatives in respect of the Stage.

20. **Force Majeure.** If either party cannot perform any obligation hereunder (other than a payment obligation) by reason of circumstances beyond such party's reasonable control, including without limitation, fire, flood, natural disasters, acts of God, war, civil commotion, labor unrest, strikes, laws or regulations, then the party affected will be excused from such performance (other than a payment obligation) on a day-to-day basis to the extent of such interference, and the other party likewise will be excused from performance of its obligations hereunder; provided the party affected shall use reasonable efforts to remove such causes of non-performance.

21. **First Right of Refusal.** Buyer agrees to grant to Seller the first right of refusal on the buy back of the Stage if the decision is taken to resell the Stage at any point in time after Buyer took possession of the asset. Terms and conditions of the buy back will be negotiated in good faith. The present clause does not create a buy back obligation for Seller.

22. **Miscellaneous.**

(a) **Notices.** All notices hereunder shall be given in writing to the address of the other party appearing at the end of this Agreement, and shall be deemed delivered: (i) upon receipt if by overnight courier or personal delivery, or (ii) seventy-two (72) hours after being mailed, registered or certified, postage prepaid, return receipt requested. Either party may change its address by written notice hereunder.

(b) **Applicable Law; Severability.** This Agreement shall be governed by the laws of the Province of Quebec, Canada. Any provision of this Agreement which may be prohibited by or otherwise held invalid, void, or unenforceable under such law shall be ineffective only to the extent of such prohibition or invalidity and shall not invalidate or render ineffective any of the remaining provisions hereof. This Agreement shall not be construed for or against either party on the basis that one party drafted the Agreement or any provision hereof.

(c) **Non-Waiver.** The failure of either party to exercise any rights in respect of any breach or alleged breach of this Agreement by the other party shall not constitute a waiver of said breach or of any provision of this Agreement, and a failure to promptly exercise any right hereunder shall not be deemed as a waiver to exercise such right in the future.

(d) **Exclusion of U.N. Convention.** The parties specifically exclude the application of each and every provision of the United Nations Convention on Contracts For The International Sale of Goods (Vienna Convention, April 11, 1980) with respect to each and every term and condition of this Agreement.

(e) **Successors.** The covenants, agreements, terms and conditions contained in this Agreement shall be binding upon and inure to the benefit of the heirs, executors, administrators, successors and assigns of the respective parties.

(f) **Arbitration; Attorneys Fees.** Any controversy, claim or dispute between the parties arising out of or relating to this Agreement, shall be settled finally by binding arbitration in Montreal, Quebec, Canada, before one arbitrator pursuant to the commercial arbitration rules of the International Chamber of Commerce. The prevailing party in the arbitration or any other legal proceeding between the parties shall be entitled to recover all of its expenses from the non-prevailing party, including without limitation the reasonable fees of attorneys and experts.

(g) **Compliance with Laws.** Buyer will have the sole responsibility for complying with all governmental laws, regulations, rules and orders with regard to Buyer's purchase and use of the Stage, including without limitation in respect of exporting the Stage from Canada and importing the Stage into any other country.

(h) **Headings.** All paragraph headings in this Agreement are for convenience only and shall not be a part of the Agreement.

(i) **Entire Agreement of the Parties.** This Agreement (including the exhibits attached hereto) constitutes the entire Agreement of the parties and supersedes any and all prior agreements, oral or written, between the parties hereto with respect to the subject matter hereof. This Agreement is intended by the parties as a final expression of their agreement with respect to the subject matter hereof and therefore this Agreement shall not be contradicted by evidence of any prior agreement or contemporaneous oral agreement.

(j) The parties further intend that this Agreement constitutes the complete and exclusive statement of its terms and that no extrinsic evidence whatsoever may be introduced in any judicial or arbitration proceeding, if any, with regard to this Agreement. Each party hereto acknowledges that no representations, inducements, promises or agreements, oral or otherwise, have been made by any party, or anyone acting on behalf of any party, which is not embodied herein, and that no other agreement, statement, or promise not contained in this Agreement shall be valid or binding. Any modification of this Agreement will be effective only if it is in writing signed by both parties to this Agreement.

(k) **Counterparts; Email Signatures.** This Agreement may be executed in counterparts and all such executed counterparts shall constitute one (1) Agreement binding on each of the parties notwithstanding that not all the parties are signatories to the original or to the same counterpart. Email signatures shall be binding and the parties agree to provide the other party with original signatures within five (5) days of the email reception.

IN WITNESS WHEREOF, the parties hereto have executed this Agreement as of

??

STAGELINE MOBILE STAGE INC.

Per: _____

Per: _____

Pierre Luc Rompre
Chief Operation Officer

Date MM/DD/YYYY

Date MM/DD/YYYY

Address:

Address:

700 Marsolais
L'Assomption, QC J5W 2G9, Canada

Annex A -Stage Quote and or Purchase Order

Annex B -Invoice

AGENDA SUMMARY
GRAND COUNTY COMMISSION MEETING
MARCH 1, 2022
 Agenda Item: I

TITLE:	Approving Clerk/Auditor Mid-Term Vacancy Appointment
FISCAL IMPACT:	
PRESENTER(S):	

Prepared By:

FOR OFFICE USE ONLY:
Attorney Review:

SUGGESTED MOTION:

I move to appoint _____ to fill the mid-term vacancy of the Grand County Clerk/Auditor, and swear them into office as interim Clerk/Auditor.

BACKGROUND:

On February 16, 2022 a notice of vacancy was issued for the resignation of Quinn Hall, Clerk/Auditor. An interim Clerk/Auditor will fill the vacancy until an elected Clerk/Auditor assumes office January 2023.

The deadline for candidates to submit a declaration of candidacy was Monday, February 28, 2022, at 5:00 pm. The Clerk received two applications.

ATTACHMENT(S):

1. Gabriel Woytek
2. Rachel Stenta

Gabriel Woytek

368 East 100 North
Moab, UT 84532
(414) 429-6959
gwoytek@gmail.com

25 February 2022

Grand County Commission

125 E. Center St.
Moab, UT 84532

Dear County Commission,

I am excited to declare my application for the midterm vacancy of the Grand County Clerk/Auditor position.

As you may know, I had made the decision not to run to maintain a seat on the County Commission, and was looking forward to finishing this year strong as Chair and charting an as yet undetermined path forward to have a positive impact in the community. I have grown a deep appreciation during my tenure for the important work done in county government and have appreciated the many positive working relationships that I have developed with those in leadership. As this vacancy came up, I realized that this would be an excellent opportunity to build on those relationships and continue to offer my dynamic skill set to the benefit of the county organization and its service to the public.

I have very consistently demonstrated the type of professionalism and ethical character that is required to serve in elected office. One of my strengths is the ability to maintain a balanced and neutral perspective and a calm level-headed approach. This quality serves me quite well as I confront challenges. This same attribute also makes me someone that anyone would enjoy collaborating with. I have found that my dependability combined with a strong work ethic has always had a positive impact in the places that I've worked, and my ability to contribute to the Clerk/Auditor's office would be no different.

While I do not have an extensive background in accounting, I have grown a general comfort and familiarity with budgeting concepts and am very confident in my intellectual capacity to understand financial record keeping with depth and breadth. I am comfortable performing all the necessary tasks entailed in an office environment, including an aptitude for technology and organization. I have always dedicated myself to being a lifelong learner, and have a track record for exhibiting the adaptability and focus necessary to master new skills and fields of knowledge. I also have a keen sense for recognizing the most

critical functions in a role and fulfilling them with the utmost quality. These aspects of my personality and professional history would allow me to grow and learn to be exactly the Clerk/Auditor that Grand County needs.

I am committed to this community on a lifelong basis and have declared my intention to run and hold this office well into the future in anticipation of the upcoming election. I am currently in the process of gathering the necessary signatures to run as an unaffiliated candidate and take on this role with passion and enthusiasm.

Thank you for your time and consideration as you make this important decision.

Best Regards,

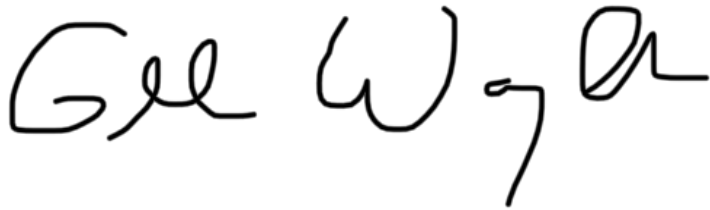
A handwritten signature in black ink that reads "Gabriel Woytek". The letters are cursive and fluidly connected.

Gabriel Woytek

Rachel E. Stenta
684 McCormick Blvd.
Moab, Utah 84532
Rachel@moabpages.com



February 23, 2022

Grand County Commission
Honorable Chair, Gabriel Woytek

Commission and Honorable Chair:

I am pleased to have the opportunity to apply for the appointment of County Clerk/Auditor. I am currently gathering signatures to file my Declaration of Candidacy for the elected position. I have lived in Moab for 28 years and I have 30 years of public service in local government and higher education. I am excited that this opportunity has arisen when I have the time and energy to contribute and continue to serve my community in a second career.

I am uniquely qualified for this position through a combination of my direct experience as a Municipal Clerk in Moab local government and my educational background in Information Systems.

As you may know, I served as the Moab City Clerk (Recorder) for 21 years which is the municipal equivalent of County Clerk. I am a Certified Municipal Clerk since 2000 and a Master Municipal Clerk since 2009 through the International Institute of Municipal Clerks. I began my local government career at Grand County in 1995 working for the County Administrator's office and then as the Economic Development Coordinator. I value County staff and appreciate firsthand the work and dedication that they provide to Grand County's citizens.

I earned a Bachelor of Science in Business – Management of Information Systems from Utah State University and I feel that having an educational background rooted in both business and technology sets me apart in the field of government accounting. I am very detail oriented, professional, communicative, and solution oriented. What I have enjoyed most about even my most stressful positions is problem solving and helping others.

During my time at the City of Moab, I prepared, managed, and analyzed the annual budget across all departments, facilitating budget accountability at all levels working with administration, frontline employees, and elected officials. I developed budget strategies that required constant communication on budgetary issues as well as review of conformity for funding allocations and disbursements. There is a definite art to fostering positive relationships with your peers while enforcing budgetary and purchasing constraints.

In my role as City Recorder, it was my honor to serve as the City's Election Officer for 21 years. I administered primary and general elections and saw many changes in our election process during that time. I worked with the Lt. Governor's office to ensure compliant and efficient elections and valued the collaborative relationship with the County Clerk's office to manage City voter registration. I admired our election officials who served our citizens to make our in-person elections a community event. I was very pleased to see the dramatic increase in voter turnout that came with By-Mail elections. Elections was one of my favorite roles in my former position.

www.linkedin.com/in/rstenta/

Rachel E. Stenta
684 McCormick Blvd.
Moab, Utah 84532
Rachel@moabpages.com

□ □ □

As City Recorder, I served as the Purchasing Officer at the City for 21 years as well as administering all procurement for the City. I served as Internal Auditor at the City ensuring that all purchases and budget allocations were in compliance with Municipal Code, Generally Accepted Accounting Principles (GAAP), and the state of Utah's Uniform Accounting Manual for Local Governments.

In my position of City Recorder, I also served as the Records Officer and was a Certified Records Officer through Utah State Archives for 22 years. I was invited by Utah State Archives to present my City Document Archiving project at their annual Sunshine Conference in 2020. I am very knowledgeable of the Government Records and Management Act (GRAMA) and made significant progress with Records Management during my time at the City. As City Recorder, I kept the City Council record for 21 years and was responsible for the City's compliance with the Open Public Meetings Act (OPMA) and conducted an annual training for our elected officials and staff. I also was the Business Licensing Official for 20 years and a Certified Business Licensing Official through the Utah Business Licensing Association.

I look forward to answering any questions you may have, and I would enjoy a chance to discuss how my skills would be of benefit to this position and our community.

I would be happy to serve as an appointed Clerk/Auditor through the end of this year, with a beginning appointment date of August 1, 2022.

Thank you for your time and consideration.

Sincerely,

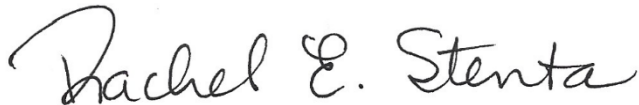

(435) 260-1116

CONSENT AGENDA SUMMARY
GRAND COUNTY COMMISSION MEETING

March 1, 2022

Consent Agenda Items: J-L

TITLE:	J. Approving a tribal consultation letter to the Ute Indian Tribe of the Uintah and Ouray Reservation regarding a HUD environmental review for Housing Authority of Southeastern Utah project funding K. Approving a tribal consultation letter to the Navajo Nation, Arizona, New Mexico, and Utah regarding a HUD environmental review for Housing Authority of Southeastern Utah project funding L. Approving a "No Historic Properties Affected" finding letter to the State Historical Preservation Office regarding a HUD environmental review for Housing Authority of Southeastern Utah project funding
FISCAL IMPACT:	See Corresponding Agenda Summaries, if any
PRESENTER(S):	None

Prepared By:

qh
435-259-1342
qhall@grandcountyutah.net

FOR OFFICE USE ONLY:

Attorney Review:

N/A

RECOMMENDATION:

I move to adopt the consent agenda as presented.

BACKGROUND:

See corresponding agenda summaries, if any, and related attachments.

ATTACHMENT(S):

See corresponding agenda summaries, if any, and related attachments.



GRAND COUNTY COMMISSION
Gabriel Woytek (Chair) · Jacques Hadler (Vice Chair)
Evan Clapper · Trish Hedin · Mary McGann
Sarah Stock · Kevin Walker

March 1, 2022

Luke Duncan, Chairperson
Ute Indian Tribe of the Uintah and Ouray Reservation, Utah
PO Box 190
Fort Duchesne, UT 84026-0190

RE: Arroyo Crossing
Physical Address: 2022 Spanish Valley Dr. Moab, UT 84532
Mailing Address: PO Box 1383 Moab, UT 84532
HUD Program

Dear Chairperson Duncan,

The Housing Authority of Southeastern Utah (HASU) is considering funding the project listed above (the Arroyo Crossing subdivision) with federal funds from the U.S. Department of Housing and Urban Development (HUD). Under HUD regulation 24 CFR 58.4, HASU has assumed HUD's environmental review responsibilities for the project, including tribal consultation related to historic properties. Historic properties include archeological sites, burial grounds, sacred landscapes or features, ceremonial areas, traditional cultural places and landscapes, plant and animal communities, and buildings and structures with significant tribal association.

HASU will conduct a review of this project to comply with Section 106 of the National Historic Preservation Act and its implementing regulations 36 CFR Part 800. We would like to invite you to be a consulting party in this review to help identify historic properties in the project area that may have religious and cultural significance to your tribe, and if such properties exist, to help assess how the project might affect them. If the project might have an adverse effect, we would like to discuss possible ways to avoid, minimize or mitigate potential adverse effects.

To provide more background information for your reference, we have included a letter from the State Historical Preservation Office (SHPO) to the USDA, who works with HASU to administer the Mutual Self-Help (MSH) program. This letter was received on March 18th, 2021, stating "we [SHPO] recommend providing the Cultural Sensitivity Training Handout (CSTH) to construction supervisors or any other on-the-ground workers for reference in the case of an inadvertent discovery or potential inadvertent discovery. With this Cultural Sensitivity Training stipulation in place, **we concur with your determination of 'No Adverse Effect' for this undertaking.**" HASU is providing this CSTH to all staff, households, and any other on-the-ground workers at the Arroyo Crossing subdivision in full compliance with this requirement.

In addition, the Grand County Public Library was contacted for any historic information that may be available for the Site. They reported that they had no historic information specific to the Site. Avant Environmental Services Inc., who conducted a Phase 1 Environmental Site Assessment for this project, concluded that there are no archeological resources that exist in the APE.

To meet project timeframes, if you would like to be a consulting party on this project, can you please let us know of your interest within 30 days? If you have any initial concerns with impacts of the project on religious or cultural properties, can you please note them in your response?

Enclosed is a map that shows the project area. In the Arroyo Crossing subdivision, there will be a total of 216 new units built in 3 phases. These 216 units will consist of 32 apartments, twenty-four 450 square foot cottages, 52 townhomes, 44 duplexes, and 64 single-family homes. These projects are currently in the pre-development stage. Possible federal funding provided to HASU by the Housing Assistance Council will help to build 10 of these single-family homes.

This subdivision is located at 2022 Spanish Valley Drive and at 2003 East Plateau Drive, Moab, Utah. It comprises two parcels totaling about 39 acres located within the southeast quarter of Section 17, Township 26 South, Range 22 East of the Salt Lake Principal Meridian. The Site is zoned MFR (southwest of Spanish Valley Drive) and large lot residential (north of Spanish Valley Drive) by Grand County Planning and Zoning. The Site lies within the USGS Moab, Utah topographic quadrangle and is at an elevation 4,380 to 4440 feet above mean sea level. The topography in the vicinity of the Site slopes gently towards the northeast towards Mill Creek. To the north are residences and a small ranch. To the east are more residences and open land. To the south is open land, south of this are several commercial properties. To the west are commercial properties and several residences.

This letter includes maps identifying the project location and phases of development, photographs showing the Arroyo Crossing subdivision, an executive summary of the Phase 1 Environmental Site Assessment performed by Avant Environmental Services Inc., and a letter received by the USDA from SHPO.

More information on the Section 106 review process is available at <http://www.onecpd.info/environmental-review/historic-preservation/>.

HUD's process for tribal consultation under Section 106 is described in a Notice available at <https://www.onecpd.info/resource/2448/notice-cpd-12-006-tribal-consultation-under-24-cfr-part-58>.

If you do not wish to consult on this project, can you please inform us? If you do wish to consult, can you please include in your reply the name and contact information for the tribe's principal representative in the consultation? Thank you very much. We value your assistance and look forward to consulting further if there are historic properties of religious and cultural significance to your tribe that may be affected by this project.

Sincerely,

Gabriel Woytek
Grand County Commission Chair
435-259-1342
commission@grandcountyutah.net



GRAND COUNTY COMMISSION
Gabriel Woytek (Chair) · Jacques Hadler (Vice Chair)
Evan Clapper · Trish Hedin · Mary McGann
Sarah Stock · Kevin Walker

March 1, 2022

Jonathan Nez, President
Navajo Nation, Arizona, New Mexico & Utah
PO Box 7440 Window Rock, AZ 86515-7440

RE: Arroyo Crossing
Physical Address: 2022 Spanish Valley Dr. Moab, UT 84532
Mailing Address: PO Box 1383 Moab, UT 84532
HUD Program

Dear President Nez,

The Housing Authority of Southeastern Utah (HASU) is considering funding the project listed above (the Arroyo Crossing subdivision) with federal funds from the U.S. Department of Housing and Urban Development (HUD). Under HUD regulation 24 CFR 58.4, HASU has assumed HUD's environmental review responsibilities for the project, including tribal consultation related to historic properties. Historic properties include archeological sites, burial grounds, sacred landscapes or features, ceremonial areas, traditional cultural places and landscapes, plant and animal communities, and buildings and structures with significant tribal association.

HASU will conduct a review of this project to comply with Section 106 of the National Historic Preservation Act and its implementing regulations 36 CFR Part 800. We would like to invite you to be a consulting party in this review to help identify historic properties in the project area that may have religious and cultural significance to your tribe, and if such properties exist, to help assess how the project might affect them. If the project might have an adverse effect, we would like to discuss possible ways to avoid, minimize or mitigate potential adverse effects.

To provide more background information for your reference, we have included a letter from the State Historical Preservation Office (SHPO) to the USDA, who works with HASU to administer the Mutual Self-Help (MSH) program. This letter was received on March 18th, 2021, stating "we [SHPO] recommend providing the Cultural Sensitivity Training Handout (CSTH) to construction supervisors or any other on-the-ground workers for reference in the case of an inadvertent discovery or potential inadvertent discovery. With this Cultural Sensitivity Training stipulation in place, we concur with your determination of 'No Adverse Effect' for this undertaking." HASU is providing this CSTH to all staff, households, and any other on-the-ground workers at the Arroyo Crossing subdivision in full compliance with this requirement.

In addition, the Grand County Public Library was contacted for any historic information that may be available for the Site. They reported that they had no historic information specific to the Site. Avant Environmental Services Inc., who conducted a Phase 1 Environmental Site

Assessment for this project, concluded that there are no archeological resources that exist in the APE.

To meet project timeframes, if you would like to be a consulting party on this project, can you please let us know of your interest within 30 days? If you have any initial concerns with impacts of the project on religious or cultural properties, can you please note them in your response?

Enclosed is a map that shows the project area. In the Arroyo Crossing subdivision, there will be a total of 216 new units built in 3 phases. These 216 units will consist of 32 apartments, twenty-four 450 square foot cottages, 52 townhomes, 44 duplexes, and 64 single-family homes. These projects are currently in the pre-development stage. Possible federal funding provided to HASU by the Housing Assistance Council will help to build 10 of these single-family homes. This subdivision is located at 2022 Spanish Valley Drive and at 2003 East Plateau Drive, Moab, Utah. It comprises two parcels totaling about 39 acres located within the southeast quarter of Section 17, Township 26 South, Range 22 East of the Salt Lake Principal Meridian. The Site is zoned MFR (southwest of Spanish Valley Drive) and large lot residential (north of Spanish Valley Drive) by Grand County Planning and Zoning. The Site lies within the USGS Moab, Utah topographic quadrangle and is at an elevation 4,380 to 4440 feet above mean sea level. The topography in the vicinity of the Site slopes gently towards the northeast towards Mill Creek. To the north are residences and a small ranch. To the east are more residences and open land. To the south is open land, south of this are several commercial properties. To the west are commercial properties and several residences.

This letter includes maps identifying the project location and phases of development, photographs showing the Arroyo Crossing subdivision, an executive summary of the Phase 1 Environmental Site Assessment performed by Avant Environmental Services Inc., and a letter received by the USDA from SHPO.

More information on the Section 106 review process is available at <http://www.onecpd.info/environmental-review/historic-preservation/>.

HUD's process for tribal consultation under Section 106 is described in a Notice available at <https://www.onecpd.info/resource/2448/notice-cpd-12-006-tribal-consultation-under-24-cfr-part-58>.

If you do not wish to consult on this project, can you please inform us? If you do wish to consult, can you please include in your reply the name and contact information for the tribe's principal representative in the consultation? Thank you very much. We value your assistance and look forward to consulting further if there are historic properties of religious and cultural significance to your tribe that may be affected by this project.

Sincerely,

Gabriel Woytek
Grand County Commission Chair
435-259-1342
commission@grandcountyutah.net



GRAND COUNTY COMMISSION
Gabriel Woytek (Chair) · Jacques Hadler (Vice Chair)
Evan Clapper · Trish Hedin · Mary McGann
Sarah Stock · Kevin Walker

March 1, 2022

State Historical Preservation office
c/o Utah Department of Heritage & Arts
300 S. Rio Grande Street
Salt Lake City, UT 84101

RE: Arroyo Crossing
Physical Address: 2022 Spanish Valley Dr. Moab, UT 84532
Mailing Address: PO Box 1383 Moab, UT 84532
HUD Program

Dear SHPO:

In accordance with Section 106 of the National Historic Preservation Act and its implementing regulations, 36 CFR Part 800, we are providing information for your review and concurrence regarding the above-referenced project. The Housing Assistance Council (HAC) is considering providing assistance to the Housing Authority of Southeastern Utah (HASU) by accepting their application for loan funds through their Self-Help Homeownership Opportunity Program (SHOP) and is subject to review under 24 CFR Part [50 or 58].

Based on our research of the property in local government tax records and a Phase 1 Environmental Site Assessment performed by Avant Environmental Services Inc. in consultation with Grand County's Planning & Zoning records, SHPO staff, and local historical groups, we have defined the Area of Potential Effect (APE) as Arroyo Crossing, located at 2022 Spanish Valley Drive and at 2003 East Plateau Drive, Moab, Utah. It comprises two parcels totaling about 39 acres located within the southeast quarter of Section 17, Township 26 South, Range 22 East of the Salt Lake Principal Meridian. The Site is zoned MFR (southwest of Spanish Valley Drive) and large lot residential (north of Spanish Valley Drive) by Grand County Planning and Zoning. The Site lies within the USGS Moab, Utah topographic quadrangle and is at an elevation 4,380 to 4440 feet above mean sea level. The topography in the vicinity of the Site slopes gently towards the northeast towards Mill Creek. To the north are residences and a small ranch. To the east are more residences and open land. To the south is open land, south of this are several commercial properties. To the west are commercial properties and several residences. In the Arroyo Crossing subdivision, there will be a total of 216 new units built in 3 phases. These 216 units will consist of 32 apartments, twenty-four 450 square foot cottages, 52 townhomes, 44 duplexes, and 64 single-family homes. The possible SHOP funding given by HAC will help HASU to build 10 of these single-family homes through its Mutual Self-Help (MSH) homeownership program.

We have made a Finding of “No Historic Properties Affected” pursuant to 36 CFR 800.4(d)(1) based on the following: the Site, called Arroyo Crossing site consists solely of new construction and there will be typical excavation without unexpected ground disturbance during construction.

This letter includes maps identifying the project location and phases of development, photographs showing the Arroyo Crossing subdivision, an executive summary of the Phase 1 Environmental Site Assessment performed by Avant Environmental Services Inc., and a letter received by the USDA from SHPO.

The project will have no effect on any historic resources on the property because there are no completed buildings that currently exist on the site.

The USDA, who works with HASU to administer the MSH program, acting in consultation with SHPO staff, received a letter from SHPO on March 18th, 2021, stating “we recommend providing the Cultural Sensitivity Training Handout (CSTH) to construction supervisors or any other on-the-ground workers for reference in the case of an inadvertent discovery or potential inadvertent discovery. With this Cultural Sensitivity Training stipulation in place, we concur with your determination of ‘No Adverse Effect’ for this undertaking.” HASU is providing this CSTH to all staff, households, and any other on-the-ground workers in full compliance with this requirement.

In addition, the Grand County Public Library was contacted for any historic information that may be available for the Site. They reported that they had no historic information specific to the Site. Avant Environmental Services Inc. concluded that there are no archeological resources that exist in the APE.

Attached for your review are copies of relevant documents supporting our finding, along with photographs and a map showing the location of the property. This documentation satisfies requirements set forth at §800.11(d).

In accordance with §800.4(d)(1)(i), your office has thirty days to object to this finding. Please respond within this timeframe, otherwise we will assume that you concur with our finding. If you concur, please sign on the line below and return a copy of this letter by fax or otherwise to 125 E. Center St. Moab UT. 84532.

If you have questions regarding this finding, please direct them to the Grand County Commission Administrators Office. Thank you for your attention to this matter.

Sincerely,

Gabriel Woytek
Commission Chair

Concurrence:

State Historic Preservation Officer

Date

Mon	Tue	Wed	Thu	Fri
31	1	2	3	4
	<p>First Day of Black History</p> <p>9am - BLM Customer Service Week</p> <p>8:30am - SARC meeting</p> <p>4pm - Commission Meeting</p>		<p>11am - Housing Task Force</p> <p>4pm - Boundary</p> <p>7pm - Water SSD & GWSSA</p>	
7	8	9	10	11
<p>Canyonlands Business</p> <p>1pm - Community</p> <p>5:30pm - Mosquito Ab. Mtg</p>	<p>11am - Trail Mix Mtg</p> <p>2pm - Conservation Dist. Mtg</p> <p>3pm - MATC Bd. Mtg</p> <p>5:30pm - OSTA Mtg</p> <p>6pm - Cemetery Bd Mtg</p> <p>6pm - Transportation SSD</p>	<p>1pm - Homeless Coordinating</p> <p>6:30pm - Thompson Water</p>	<p>12:30pm - Motorized Trails</p> <p>5:30pm - Cany Healthcare</p>	
14	15	16	17	18
<p>Valentine's Day</p> <p>12:30pm - Council on Aging</p> <p>4:30pm - Planning</p>	<p>9am - EMS SSD meeting @</p> <p>4pm - Commission Meeting</p> <p>4pm - Moab Fire Protection</p> <p>4pm - TSSSFD Mtg</p>	<p>1:30pm - Perf. Rvw. Mtg</p> <p>5:30pm - Museum Mtg</p> <p>7pm - Rec. SSD Bd. Mtg @</p>	<p>12pm - HASU Bd. Mtg</p> <p>4pm - Arches SSD Mtg</p> <p>7pm - Water SSD & GWSSA</p>	
21	22	23	24	25
<p>Presidents' Day</p>		<p>8:30am - Chamber of</p> <p>4pm - Solid Waste SSD Mtg</p>	<p>12pm - SEUALG Mtg</p>	
28	1	2	3	4
<p>4:30pm - Planning</p>	<p>First Day of Women's History</p> <p>8:30am - SARC meeting</p> <p>4pm - Commission Meeting</p>		<p>11am - Housing Task Force</p> <p>7pm - Water SSD & GWSSA</p>	